

# Smart Power



Haier

## CONTENTS

<b>Part 1 General Information .....</b>	<b>1</b>
1. Nomenclature .....	2
2. Line up.....	3
3. Feature .....	4
<b>Part 2 Indoor Units--4-Way Cassette Type .....</b>	<b>6</b>
1. Feature .....	7
2. Specification .....	8
3. Dimension .....	14
4. Wiring diagram .....	15
5. Air velocity and temperature distribution .....	16
6. Sound pressure level.....	20
7. Installation .....	23
8. Test run.....	29
<b>Part 3 Indoor Units-Medium ESP duct type .....</b>	<b>30</b>
1. Feature .....	31
2. Specification .....	33
3. Dimension .....	39
4. Wiring diagram .....	41
5. Airflow and Static Pressure Chart.....	43
6. Instalaltion .....	46
7. Sound pressure leve .....	53
<b>Part 4 Outdoor Units .....</b>	<b>54</b>
1. Specification .....	55
2. Dimension .....	61
3. Piping diagram .....	63
4. Wiring diagram .....	64
5. Noise level.....	67
6. Outdoor performace curves.....	73
7. Installation .....	79
<b>Part 5 Electric Control and Toubleshooting.....</b>	<b>100</b>
1. Indoor unit .....	101
2. Indoor unit dip switch setting .....	102
3. Outdoor unit PCB photo .....	105
4. Failure code.....	107
5. Instructions of parameters & error code checking.....	123
6. Function.....	132
7.Controller.....	144
<b>Appendix Sensor Characteristic .....</b>	<b>160</b>

**Part 1 General Information**

1. Nomenclature .....2  
2. Line up.....3  
3. Feature .....3

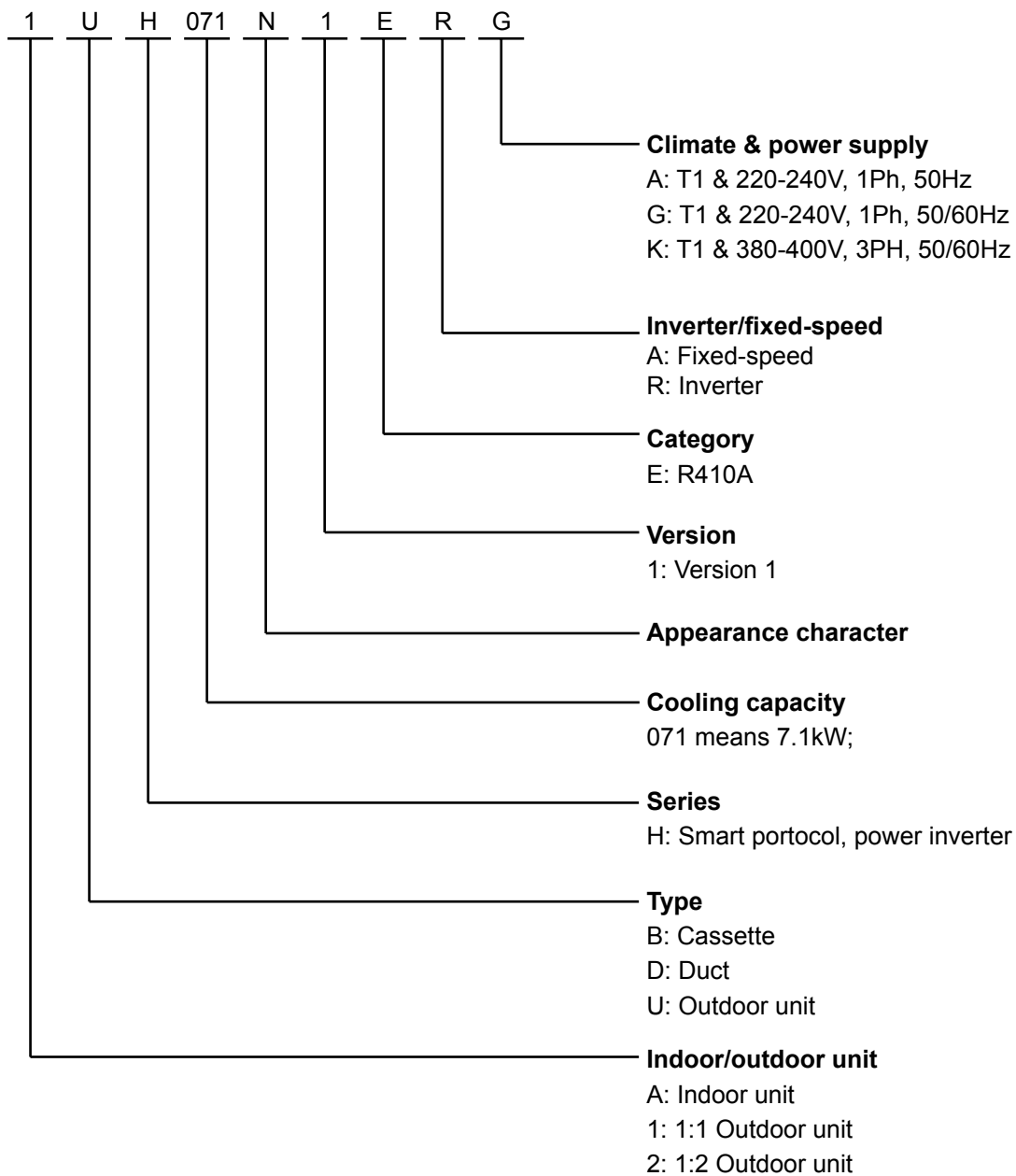

## 1. Nomenclature







2. Line up

	Model	Apperance
Outdoor unit	1UH071N1ERG 1UH090N1ERG 1UH105N1ERG	
	1UH125P1ERG 1UH125P1ERK 1UH140P1ERK	

		Model	Apperance
Indoor unit	4-Way Cassette	ABH071H1ERG ABH090H1ERG ABH105H1ERG	
		ABH125K1ERG ABH140K1ERG	
	Medium Esp Duct	ADH071M1ERG ADH090M1ERG	
		ADH105M1ERG ADH125M1ERG ADH140M1ERG	

		Model	Apperance
Panel	4-Way Cassette	PB-950KB	
		PB-950MB	

### 3. Feature

#### Double side 4 handles

Because of double side 4 handles design, it is very easy for 2 peoples carry it.



#### Stylish Design

##### Built-in valve design

The new built-in valve design, it can realize 4 way pipe connection (front, rear, right, down), it is more beautiful and easy installation.



#### Easy Installation

##### "888" digital test panel

All running parameters & error code can be checked from "888" digital display, installer can make easy work.

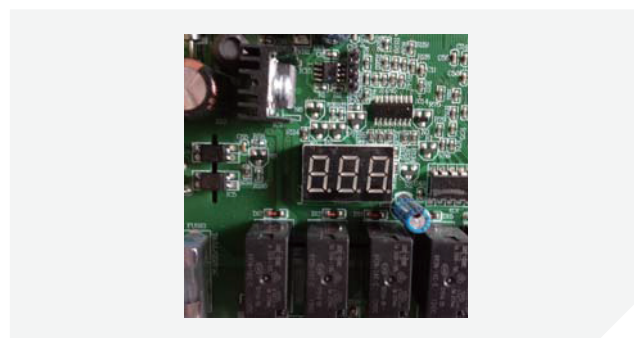

#### Wired controller data check

Running parameters can be checked by controller, if installer is not easy to go to the outdoor unit site, just stay indoor to check, installer can make easy work.



**Low Sound Level**  
**Super big inlet grille**

Compared to conventional air inlet grill, we enlarge the air inlet area by 23%, lower air speed & lower the sound level.

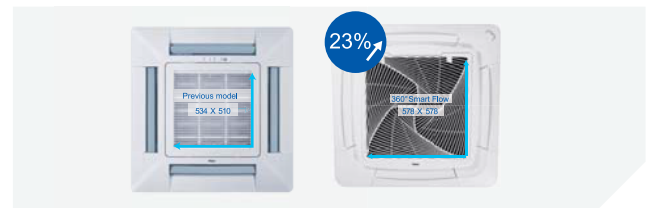

**New designed fan**

The diameter of new fan is enlarged based on acrodynamic theory, so that there is the least resistance against airflow. Reduce 3dB (A) for sound level.



**Comfort Airflow**

**360° air supply**

360° air supply without blind spot.

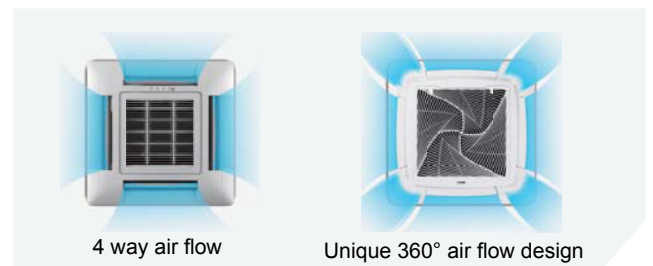

**Easy Installation**

**Convenient clip**

There is clip to lock the panel. Just one installer can finish the screwing for panel. Save manpower and easy installation.



**High lift-up drain pump**

It can lift condensed water up to 1200mm, which is more flexible to install the duct according to the layout.



## Part 2 Indoor Units--4-Way Cassette Type

1. Feature .....	7
2. Specification .....	8
3. Dimension .....	14
4. Wiring diagram .....	15
5. Air velocity and temperature distribution .....	16
6. Sound pressure level.....	20
7. Installation .....	23
8. Test run.....	29

**1. Feature**

**Stylish Design**

**"Spiral" panel**

"Spiral" concept, "Haier" image.



**Flap is closed when air conditioner off**

There is no crack from the flap and the panel when the air conditioner off. More elegance.



**ABS material panel**

ABS material makes the panel "piano white", different from "dark white" PS material color. The panel and flap are the same material. After 10 years, the panel color won't change to yellow color because the ABS material prevents discoloration against light raying.



**New designed fan**

The diameter of new fan is enlarged based on acrodynamic theory, so that there is the least resistance against airflow. Reduce 3dB (A) for sound level.



**Individual flap control**

The four flaps can be controlled individually according to end users by controller, providing maximum comfort throughout the room, it is a good solution to avoid "air conditioning disease".

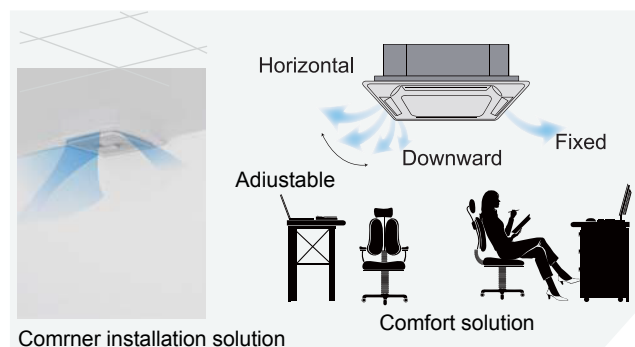

## 2. Specification

Item		Model	ABH071H1ERG/1UH071N1ERG				
Function			Cooling	Heating			
Capacity		kW	7.1 (2.0~8.0)	7.8 (2.0~9.0)			
Sensible heat ratio			0.72	/			
Total power input		kW	1.89 (0.4~4.0)	2.0 (0.4~4.0)			
Max. power input		W	4000				
AEER or ACOP		W/W	3.65	3.8			
Dehumidifying capacity		10 <sup>-3</sup> ×m <sup>3</sup> /h	2.4				
Power cable			4.0mm <sup>2</sup>				
Power source		N, V, Hz	1PH, 220-240V~, 50/60Hz				
Running/Max. Running current		A/A	8.7 (2.0-17.5)/17.5	9.1 (2.0-17.5)/17.5			
Start current		A	3				
Circuit breaker		A	30				
Indoor unit	Unit model (color)		ABH071H1ERG				
	Fan	Type×Number	CENTRIFUGALX1				
		Speed (H-M-L-SL)	r/min	500/400/300/250			
		Fan motor output/input power	W	72/112			
		Air-flow (H-M-L-SL)	m <sup>3</sup> /h	1260/1070/820/680			
	Heat exchanger	Type/Diameter	mm	Inner grooved pipe/φ7.0			
		Row		2			
		Total area	m <sup>2</sup>	/			
	Dimension	External (L×W×H)	mm×mm×mm	840/840/246			
		Package (L×W×H)	mm×mm×mm	990/990/310			
	Drainage pipe (material, I.D./O.D.)		mm	PVC 26/32			
	Controller (O-Optional, S-Standard)		Wired	YR-E16A(O)/YR-E17(O)			
			Infrared	YR-HBS01(S)			
	Fresh air hole dimension		mm	95			
	Electricity heater		kW	/			
	Sound power noise level (H)		dB (A)	52			
	Sound pressure noise level (H-M-L-SL)		dB (A)	36/33/29/26			
	Weight (Net/Shipping)		kg/kg	31/36			
	Panel	Model		PB-950KB/PB-950MB			
		External dimensions (W/D/H)		mm	950/950/50		
Shipping dimensions (W/D/H)		mm	1000/1000/110				
Net weight/Shipping weight		kg	6.5/9				
Piping	Refrigerant	Type/Charge	g	R410A/2500			
		Recharge quantity	g/m	45			
	Pipe	Liquid	mm	9.52			
		Gas	mm	15.88			
		Max pipe length(without charge refrigerant)	m	20			
	Between I.D & O.D	MAX. Drop	m	30			
		MAX. Piping length	m	50			
Connection method			Flared				
Cooling		Pdesignc (kW) :	7.1kW	SEER/CLASS	6.3/A++	QCE (Annual electricity consumption for cooling) kWh:	377
Heating	Average	Pdesignh (-10°C)	6.0kW	SCOP/CLASS	4.2/A+	QHE (Annual electricity consumption for heating) kWh:	1899
	Warmer	Pdesignh (2°C)	6.5kW	SCOP/CLASS	4.8/A++		1615
	Colder	Pdesignh (-22°C)	/	SCOP/CLASS	/		/
Tdesignh: -10°C		Tbivalent: -8°C		TOL: -20°C		Elbu: 0	
Max. cooling condition		Indoor temperature: 32°C/23°C		Max. heating condition		Indoor temperature: 27°C/-°C	
		Outdoor temperature: 46°C/-°C				Outdoor temperature: 24°C/18°C	
Norminal condition: Indoor temperature (cooling) : 27DB (°C)/19WB (°C) , Indoor temperature (heating) : 20DB (°C) Outdoor temperature (cooling) : 35DB (°C)/24WB (°C) , Outdoor temperature (heating) : 7DB (°C)/6WB (°C) The noise level will be measured in the third octave band limited values, using a Real Time Analyser calibrated sound intensity meter. It is a sound pressure noise level.							

Item		Model	ABH090H1ERG/1UH090N1ERG				
Function			Cooling	Heating			
Capacity		kW	9 (2.5~10)	10.1 (2.5~11)			
Sensible heat ratio			0.72	/			
Total power input		kW	2.56 (0.5~4.4)	2.69 (0.5~4.4)			
Max. power input		W	4400				
AEER or ACOP		W/W	3.44	3.87			
Dehumidifying capacity		10 <sup>-3</sup> ×m <sup>3</sup> /h	2.5				
Power cable			4.0mm <sup>2</sup>				
Power source		N, V, Hz	1PH, 220-240V~, 50/60Hz				
Running/Max. Running current		A/A	11.6 (2.3-19.2)/19.2	11.9 (2.3-19.2)/19.2			
Start current		A	3				
Circuit breaker		A	30				
Indoor unit	Unit model (color)		ABH090H1ERG				
	Fan	Type×Number		CENTRIFUGALX1			
		Speed (H-M-L-SL)		r/min	600/500/400/350		
		Fan motor output/input power		W	77/125		
		Air-flow (H-M-L-SL)		m <sup>3</sup> /h	1470/1260/1050/940		
	Heat exchanger	Type/Diameter		mm			
		Row		Inner grooved pipe/φ7.0			
		Total area		m <sup>2</sup>			
	Dimension	External (L×W×H)		mm×mm×mm			
		Package (L×W×H)		mm×mm×mm			
	Drainage pipe (material, I.D./O.D.)		mm				
	Controller (O-Optional, S-Standard)		Wired		YR-E16A(O)/YR-E17(O)		
			Infrared		YR-HBS01(S)		
	Fresh air hole dimension		mm				
	Electricity heater		kW				
	Sound power noise level (H)		dB (A)				
	Sound pressure noise level (H-M-L-SL)		dB (A)				
Weight (Net/Shipping)		kg/kg					
Panel	Model		PB-950KB/PB-950MB				
	External dimensions (W/D/H)		mm				
	Shipping dimensions (W/D/H)		mm				
	Net weight/Shipping weight		kg				
Piping	Refrigerant		Type/Charge				
			g				
	Pipe		Recharge quantity				
			g/m				
	Between I.D & O.D		Liquid				
			mm				
			Gas				
MAX. Drop		mm					
		15.88					
MAX. Piping length		m					
Connection method		m					
		Flared					
Cooling	Pdesignc (kW) :	9kW	SEER/CLASS	6.3/A++	QCE (Annual electricity consumption for cooling) kWh:	516	
Heating	Average	Pdesignh (-10°C)	8.1kW	SCOP/CLASS	4.1/A+	QHE (Annual electricity consumption for heating) kWh:	2798
	Warmer	Pdesignh (2°C)	8.8kW	SCOP/CLASS	4.8/A++		2416
	Colder	Pdesignh (-22°C)	/	SCOP/CLASS	/		/
Tdesignh: -10°C		Tbivalent: -8°C		TOL: -20°C		Elbu: 0	
Max. cooling condition		Indoor temperature: 32°C/23°C		Max. heating condition		Indoor temperature: 27°C/-°C	
		Outdoor temperature: 46°C/-°C				Outdoor temperature: 24°C/18°C	
Norminal condition:							
Indoor temperature (cooling) : 27DB (°C)/19WB (°C) , Indoor temperature (heating) : 20DB (°C)							
Outdoor temperature (cooling) : 35DB (°C)/24WB (°C) , Outdoor temperature (heating) : 7DB (°C)/6WB (°C)							
The noise level will be measured in the third octave band limited values, using a Real Time Analyser calibrated sound intensity meter.							
It is a sound pressure noise level.							



Item		Model	ABH105H1ERG/1UH105N1ERG			
Function			Cooling		Heating	
Capacity		KW	10 (2.5~11)		10.6 (2.5~11.3)	
Sensible heat ratio			0.72		/	
Total power input		KW	2.99 (0.5~4.9)		2.86 (0.5~4.9)	
Max. power input		W	4900			
AEER or ACOP		W/W	3.29		3.64	
Dehumidifying capacity		10 <sup>-3</sup> ×m <sup>3</sup> /h	3			
Power cable			4.0mm <sup>2</sup>			
Power source		N, V, Hz	1PH, 220-240V~, 50/60Hz			
Running/Max. Running current		A/A	13.6 (2.3-20)/20		12.7 (2.3-20)/20	
Start current		A	3			
Circuit breaker		A	30			
Indoor unit	Unit model (color)		ABH105H1ERG			
	Fan	Type×Number	CENTRIFUGALX1			
		Speed (H-M-L-SL)	r/min	650/550/450/400		
		Fan motor output/input power	W	82/134		
		Air-flow (H-M-L-SL)	m <sup>3</sup> /h	1680/1530/1320/1190		
	Heat exchanger	Type/Diameter	mm	Inner grooved pipe/φ7.0		
		Row		2		
		Total area	m <sup>2</sup>	/		
	Dimension	External (L×W×H)	mm×mm×mm	840/840/246		
		Package(L×W×H)	mm×mm×mm	990/990/310		
	Drainage pipe (material, I.D./O.D.)		mm	PVC 26/32		
	Controller (O-Optional, S-Standard)		Wired	YR-E16A(O)/YR-E17(O)		
			Infrared	YR-HBS01(S)		
	Fresh air hole dimension		mm	95		
	Electricity heater		kW	/		
	Sound power noise level (H)		dB (A)	62		
	Sound pressure noise level (H-M-L)		dB (A)	45/42/38/34		
	Weight (Net/Shipping)		kg/kg	31/36		
	Panel	Model		PB-950KB/PB-950MB		
		External dimensions (W/D/H)		mm	950/950/50	
Shipping dimensions (W/D/H)		mm	1000/1000/110			
Net weight/Shipping weight		kg	6.5/9			
Piping	Refrigerant		Type/Charge	g		R410A/2500
			Recharge quantity	g/m		45
	Pipe	Liquid		mm		9.52
		Gas		mm		15.88
		Max pipe length(without charge refrigerant)		m		20
	Between I.D & O.D	MAX. Drop		m		30
MAX. Piping length		m		50		
Connection method		Flared				
Cooling		Pdesignc (kW) :	10kW	SEER/CLASS	6.8/A++	QCE (Annual electricity consumption for cooling) kWh: 538
Heating	Average	Pdesignh (-10°C)	8.2kW	SCOP/CLASS	4.1/A+	QHE (Annual electricity consumption for heating) kWh: 2900
	Warmer	Pdesignh (2°C)	8.8kW	SCOP/CLASS	4.8/A++	2566
	Colder	Pdesignh (-22°C)	/	SCOP/CLASS	/	/
Tdesignh: -10°C		Tbivalent: -8°C		TOL: -20°C		Elbu: 0
Max. cooling condition		Indoor temperature: 32°C/23°C		Max. heating condition		Indoor temperature: 27°C/-°C
		Outdoor temperature: 46°C/-°C				Outdoor temperature: 24°C/18°C
Norminal condition:						
Indoor temperature (cooling) : 27DB (°C)/19WB (°C) , Indoor temperature (heating) : 20DB (°C)						
Outdoor temperature (cooling) : 35DB (°C)/24WB (°C) , Outdoor temperature (heating) : 7DB (°C)/6WB (°C)						
The noise level will be measured in the third octave band limited values, using a Real Time Analyser calibrated sound intensity meter.						
It is a sound pressure noise level.						



Item		Model	ABH125K1ERG/1UH125P1ERK		
Function			Cooling	Heating	
Capacity		kW	12.5 (3.5~14.5)	13.1 (4~17)	
Sensible heat ratio			0.74		
Total power input		kW	3.67 (1.0-6.5)	3.71 (1.0-6.5)	
Max. power input		W	7000		
AEER or ACOP		W/W	3.38	3.50	
Dehumidifying capacity		10 <sup>-3</sup> ×m <sup>3</sup> /h	4.9		
Power cable			4.0mm <sup>2</sup>		
Power source		N, V, Hz	3PH~, 380~415, 50/60Hz		
Running/Max. Running current		A/A	6.1/10.8	6.3/10.8	
Start current		A	3		
Circuit breaker		A	40		
Indoor unit	Unit model (color)		ABH125K1ERG		
	Fan	Type×Number	CENTRIFUGALX1		
		Speed (H-M-L)	r/min	750/650/500	
		Fan motor input power	kW	0.12	
		Fan motor output power	kW	0.09	
		Air-flow (H-M-L)	m <sup>3</sup> /h	1950/1600/1440	
	Heat exchanger	Type/Diameter	mm	Inner grooved pipe/φ7.0	
		Total area	m <sup>2</sup>	/	
	Dimension	External(L×W×H)	mm×mm×mm	840/840/288	
		Package (L×W×H)	mm×mm×mm	990*990*380	
	Drainage pipe (material, I.D./O.D.)		mm	PVC 21/25	
	Controller (O-Optional, S-Standard)		Wired	YR-E17(O)/ YR-E16A(O)	
			Infrared	YR-HBS01(S)	
	Fresh air hole dimension		mm	75	
	Electricity heater		kW	/	
	Sound power Noise level (H)		dB (A)	64	
	Sound pressure Noise level (H-M-L)		dB (A)	48/45/52	
	Weight (Net/Shipping)		kg/kg	40/45	
	Panel	Model		PB-950KB/PB-950MB	
		External dimensions (W/D/H)		mm	950/950/50
Shipping dimensions (W/D/H)		mm	1000/1000/110		
Net weight/Shipping weight		kg	6.5/9.0		
Piping	Refrigerant	Type/Charge	g	R410A/3700	
		Recharge quantity	g/m	45	
	Pipe	Liquid	mm	9.52	
		Gas	mm	15.88	
		Max pipe length(without charge refrigerant)	m	30	
	Between I.D & O.D	MAX. Drop	m	30	
MAX. Piping length		m	75		
Connection method			Flared		

Norminal condition:

Indoor temperature (cooling) : 27DB (°C)/19WB (°C) , Indoor temperature (heating) : 20DB (°C)

Outdoor temperature (cooling) : 35DB (°C)/24WB (°C) , Outdoor temperature (heating) : 7DB (°C)/6WB (°C)

The noise level will be measured in the third octave band limited values, using a Real Time Analyser calibrated sound intensity meter.

It is a sound pressure noise level.

Item		Model	ABH125K1ERG/1UH125P1ERG		
Function			Cooling	Heating	
Capacity		kW	12.5 (3.5~14.5)	13.1 (4~17)	
Sensible heat ratio			0.74		
Total power input		kW	3.67	3.71	
Max. power input		W	6500		
AEER or ACOP		W/W	3.38	3.50	
Dehumidifying capacity		10 <sup>-3</sup> ×m <sup>3</sup> /h	4.9		
Power cable			6.0mm <sup>2</sup>		
Power source		N, V, Hz	1, 220~240, 50/60		
Running/Max. Running current		A/A	17.0 (8.7-30.0)/30A	17.2 (8.7-30.0)/30A	
Start current		A	3		
Circuit breaker		A	40		
Indoor unit	Unit model (color)		ABH125K1ERG		
	Fan	Type×Number	CENTRIFUGALX1		
		Speed (H-M-L)	r/min	750/650/500	
		Fan motor input power	kW	0.12	
		Fan motor output power	kW	0.09	
		Air-flow (H-M-L)	m <sup>3</sup> /h	1950/1600/1440	
	Heat exchanger	Type/Diameter	mm	Inner grooved pipe/φ7.0	
		Total area	m <sup>2</sup>	/	
	Dimension	External (L×W×H)	mm×mm×mm	840/840/288	
		Package (L×W×H)	mm×mm×mm	990*990*380	
	Drainage pipe (material, I.D./O.D.)		mm	PVC 21/25	
	Controller (O-Optional, S-Standard)		Wired	YR-E17(O) or YR-E16A(O)	
			Infrared	YR-HBS01 (S)	
	Fresh air hole dimension		mm	75	
	Electricity heater		kW	/	
	Sound power Noise level (H)		dB (A)	64	
	Sound pressure Noise level (H-M-L)		dB (A)	48/45/42	
Weight (Net/Shipping)		kg/kg	40/45		
Panel	Model		PB-950KB/PB-950MB		
	External dimensions (W/D/H)		mm	950/950/50	
	Shipping dimensions (W/D/H)		mm	1000/1000/110	
	Net weight/Shipping weight		kg	6.5/9.0	
Piping	Refrigerant	Type/Charge	g	R410A/3700	
		Recharge quantity	g/m	45	
	Pipe	Liquid	mm	9.52	
		Gas	mm	15.88	
		Max pipe length(without charge refrigerant)	m	30	
Between I.D &O.D	MAX. Drop	m	30		
	MAX. Piping length	m	75		
Connection method			Flared		

Normal condition:

Indoor temperature (cooling) : 27DB (°C)/19WB (°C) , Indoor temperature (heating) : 20DB (°C)

Outdoor temperature (cooling) : 35DB (°C)/24WB (°C) , Outdoor temperature (heating) : 7DB (°C)/6WB (°C)

The noise level will be measured in the third octave band limited values, using a Real Time Analyser calibrated sound intensity meter. It is a sound pressure noise level.

Item		Model	ABH140K1ERG/1UH140P1ERK		
Function			Cooling	Heating	
Capacity		kW	13.4 (3.5~15.0)	14.5 (4.0~18.0)	
Sensible heat ratio			0.74		
Total power input		kW	4.05	4.11	
Max. power input		W	7200		
AEER or ACOP		W/W	3.27	3.48	
Dehumidifying capacity		10 <sup>-3</sup> ×m <sup>3</sup> /h	4.9		
Power cable			4.0mm <sup>2</sup>		
Power source		N, V, Hz	3PH~, 380~415, 50/60Hz		
Running/Max. Running current		A/A	6.8/11.0	7.0/11.0	
Start current		A	3		
Circuit breaker		A	30		
Indoor unit	Unit model (color)		ABH140K1ERG		
	Fan	Type×Number		CENTRIFUGALX1	
		Speed (H-M-L)		r/min	750/650/550
		Fan motor input power		kW	0.12
		Fan motor output power		kW	0.09
		Air-flow (H-M-L)		m <sup>3</sup> /h	1950/1600/1440
	Heat exchanger	Type/Diameter		mm Inner grooved pipe/φ7.0	
		Total area		m <sup>2</sup> /	
	Dimension	External (L×W×H)		mm×mm×mm 840/840/288	
		Package (L×W×H)		mm×mm×mm 990*990*380	
	Drainage pipe (material, I.D./O.D.)		mm	PVC 21/25	
	Controller (O-Optional, S-Standard)		Wired	YR-E17(O) OR YR-E16A(O)	
			Infrared	YR-HBS01 (S)	
	Fresh air hole dimension		mm	75	
	Electricity heater		kW	/	
	Sound power Noise level (H-M-L)		dB (A)	64	
	Sound pressure Noise level (H-M-L)		dB (A)	48/45/42	
Weight (Net/Shipping)		kg/kg	32/38		
Panel	Model		PB-950KB/PB-950KB		
	External dimensions (W/D/H)		mm	950/950/50	
	Shipping dimensions (W/D/H)		mm	1000/1000/110	
	Net weight/Shipping weight		kg	6.5/9.0	
Piping	Refrigerant	Type/Charge	g	R410A/3700	
		Recharge quantity	g/m	45	
	Pipe	Liquid	mm	9.52	
		Gas	mm	15.88	
		Max pipe length(without charge refrigerant)	m	30	
Between I.D &O.D	MAX. Drop	m	30		
	MAX. Piping length	m	75		
Connection method			Flared		

Norminal condition:

Indoor temperature (cooling) : 27DB (°C)/19WB (°C) , Indoor temperature (heating) : 20DB (°C)

Outdoor temperature (cooling) : 35DB (°C)/24WB (°C) , Outdoor temperature (heating) : 7DB (°C)/6WB (°C)

The noise level will be measured in the third octave band limited values, using a Real Time Analyser calibrated sound intensity meter. It is a sound pressure noise level.

### 3. Dimension

ABH071H1ERG/ABH090H1ERG/ABH105H1ERG

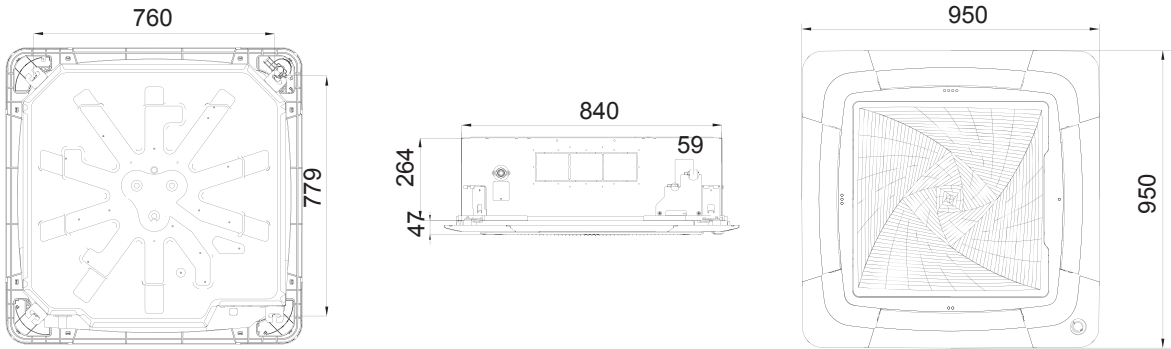

ABH125K1ERG/ABH140K1ERG

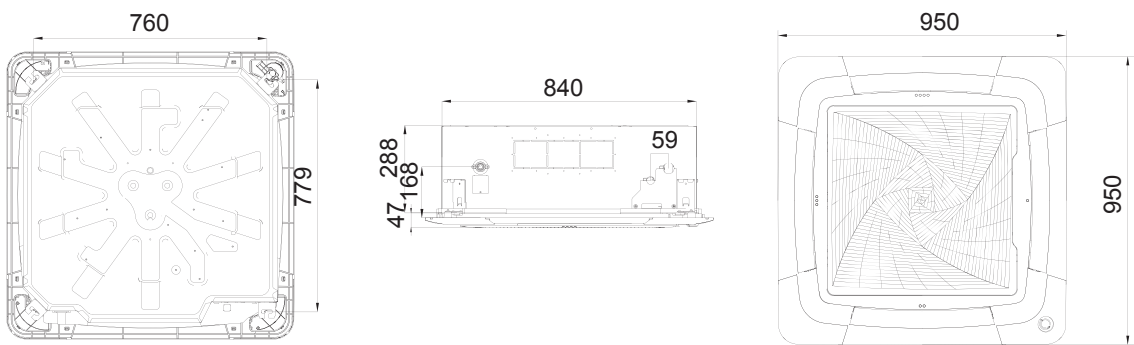

4. Wiring diagram

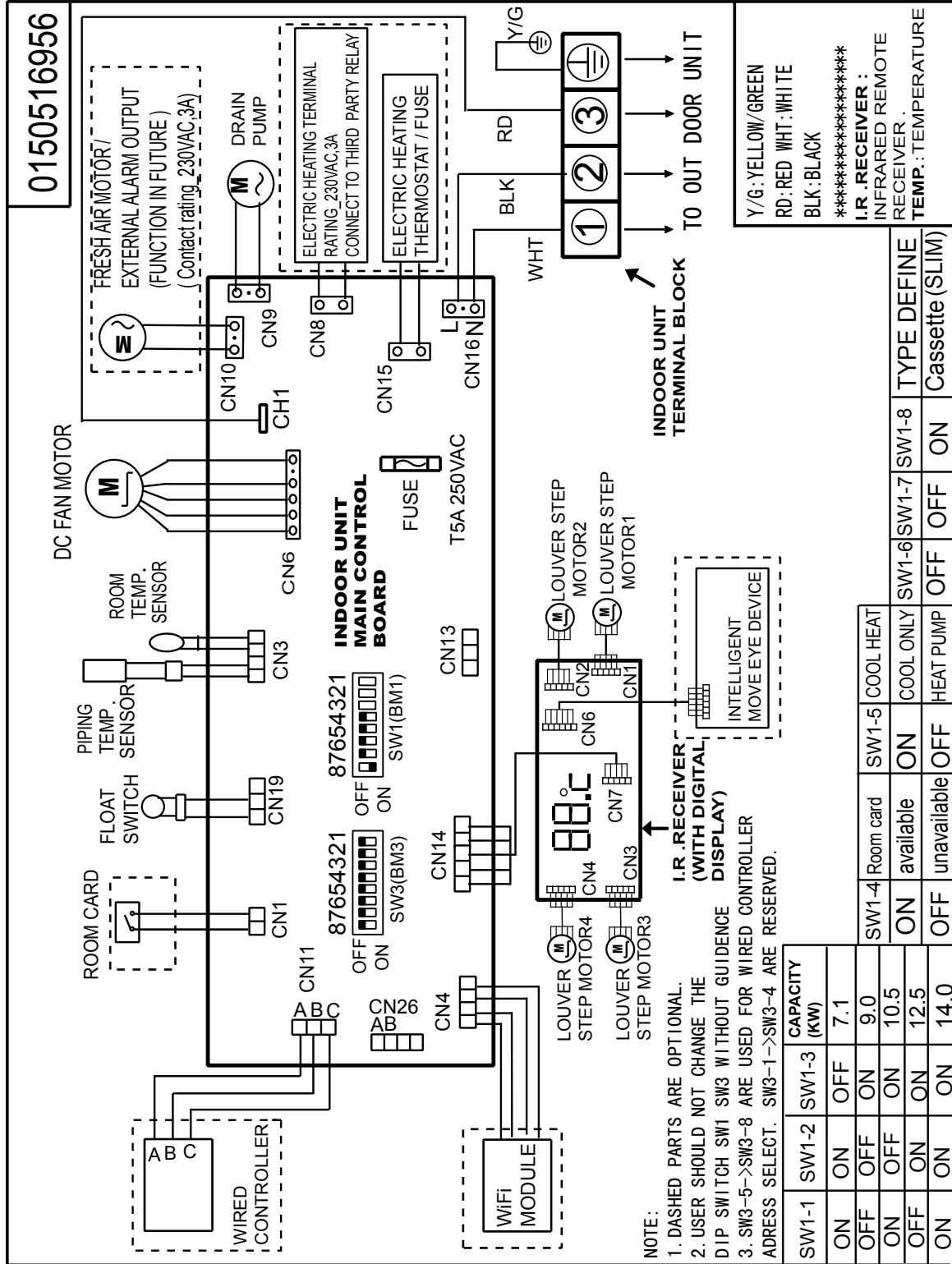

NOTE:  
 1. DASHED PARTS ARE OPTIONAL.  
 2. USER SHOULD NOT CHANGE THE DIP SWITCH SW1 SW3 WITHOUT GUIDENCE  
 3. SW3-5->SW3-8 ARE USED FOR WIRED CONTROLLER ADDRESS SELECT. SW3-1->SW3-4 ARE RESERVED.

SW1-1	SW1-2	SW1-3	CAPACITY (KW)	SW1-4	Room card	SW1-5	COOL HEAT	SW1-6	SW1-7	SW1-8	TYPE DEFINE
ON	ON	OFF	7.1	SW1-4	ON	COOL ONLY	HEAT PUMP	OFF	OFF	ON	Cassette (SLIM)
OFF	OFF	ON	9.0	SW1-4	OFF	HEAT ONLY	COOL HEAT	ON	ON	OFF	
ON	OFF	ON	10.5	SW1-4	available	COOL ONLY	HEAT PUMP	OFF	OFF	ON	
OFF	ON	ON	12.5	SW1-4	unavailable	COOL ONLY	HEAT PUMP	OFF	OFF	ON	
ON	ON	ON	14.0	SW1-4	OFF	COOL ONLY	HEAT PUMP	OFF	OFF	ON	

## 5. Air velocity and temperature distribution

**ABH071/090/105H1ERG:**

a. Cooling/Air velocity distribution

Cooling

Blow angle: 33

Air velocity distribution

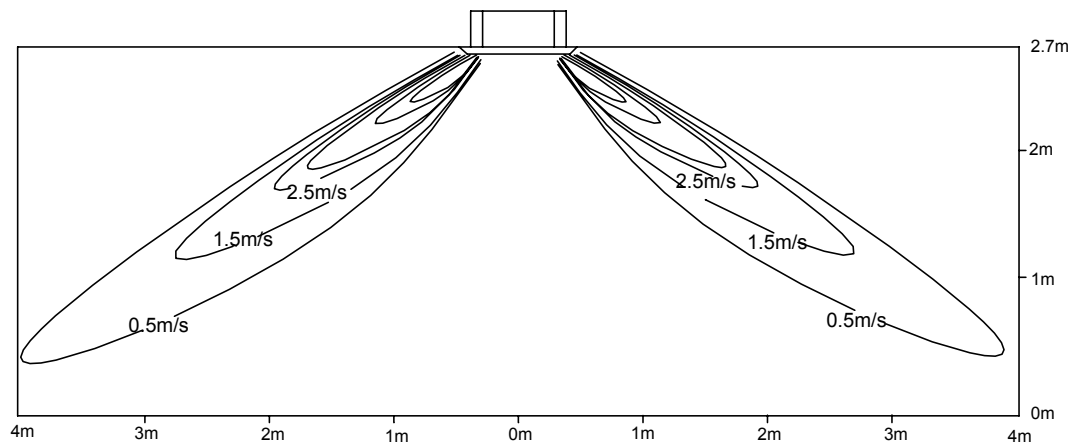

b. Cooling/Temperature distribution

Cooling

Blow angle: 33

Temperature distribution

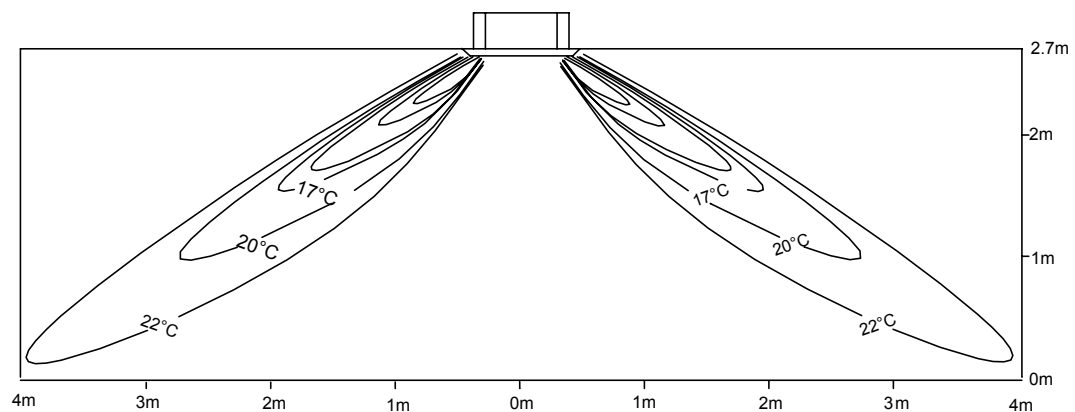

c. Heating/Air velocity distribution

Heating

Blow angle: 60

Air velocity distribution

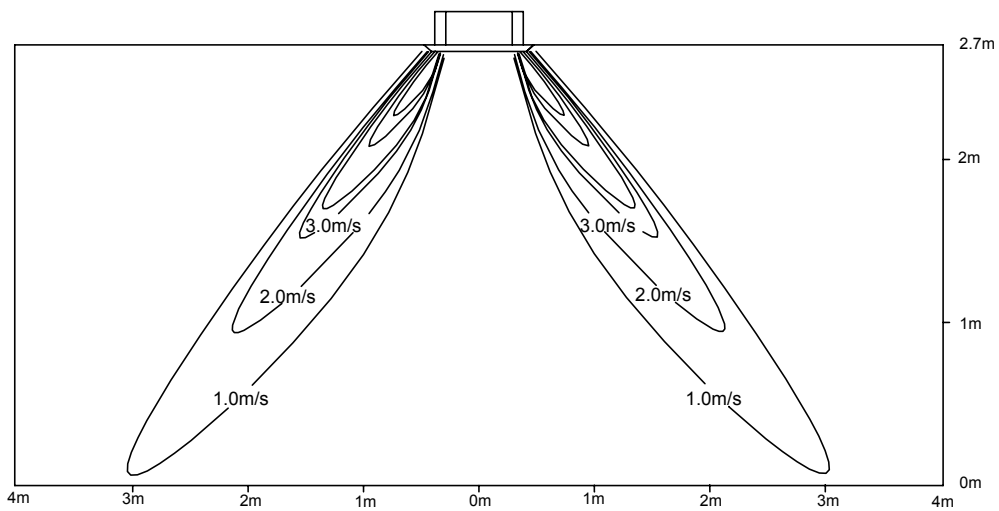

d. Heating/Temperature distribution

Heating

Blow angle: 60

Temperature distribution

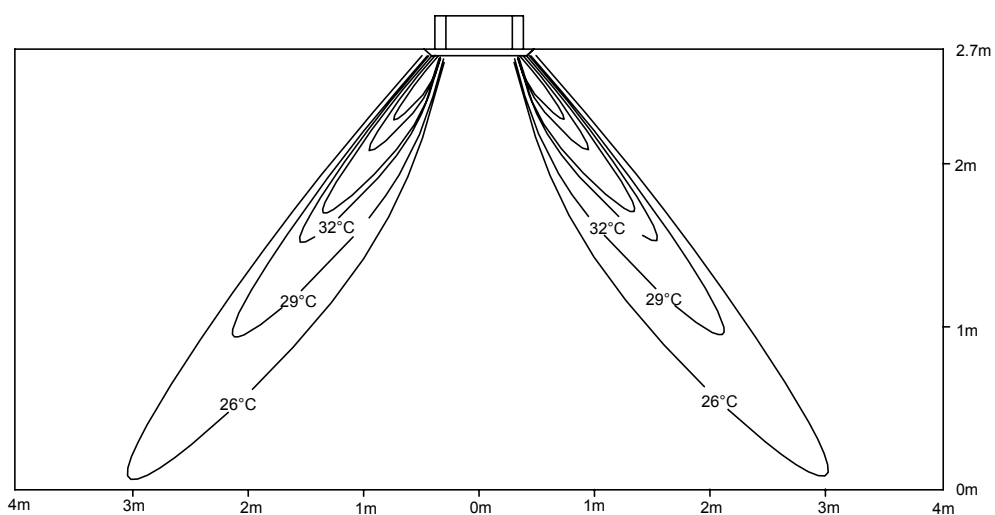

## AB125-140

### a. Cooling/Air velocity distribution

Cooling

Blow angle: 33

Air velocity distribution

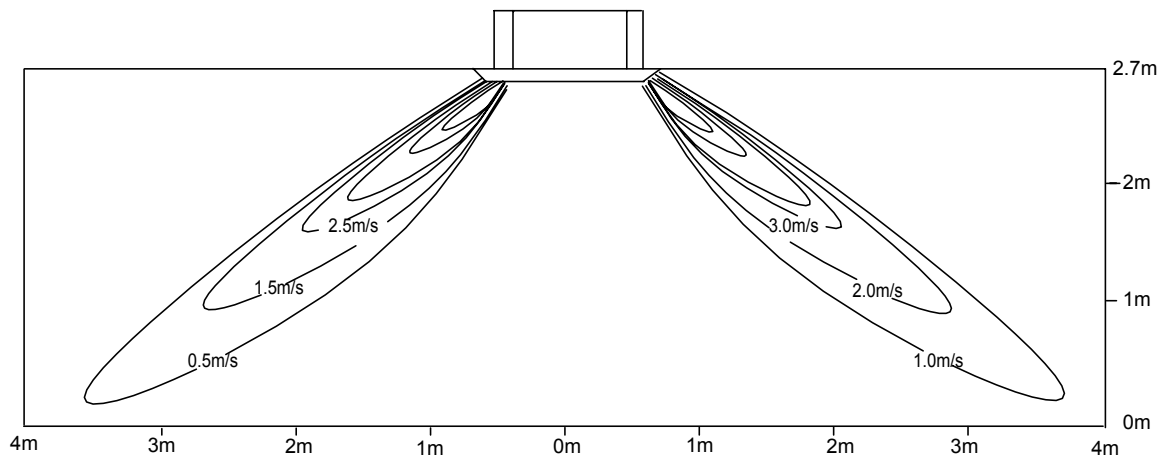

### b. Cooling/Temperature distribution

Cooling

Blow angle: 33

Temperature distribution

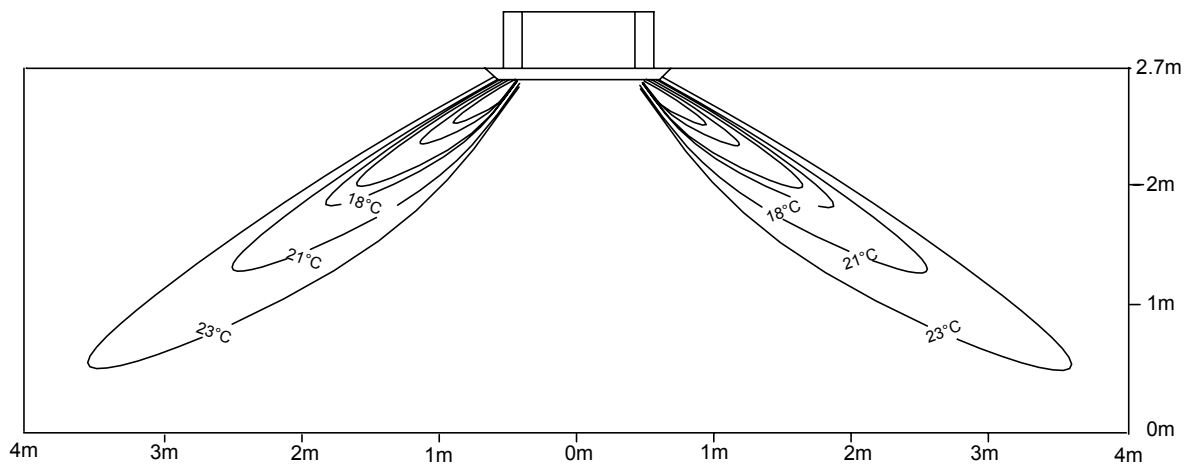



c. Heating/Air velocity distribution

Heating

Blow angle: 60

Air velocity distribution

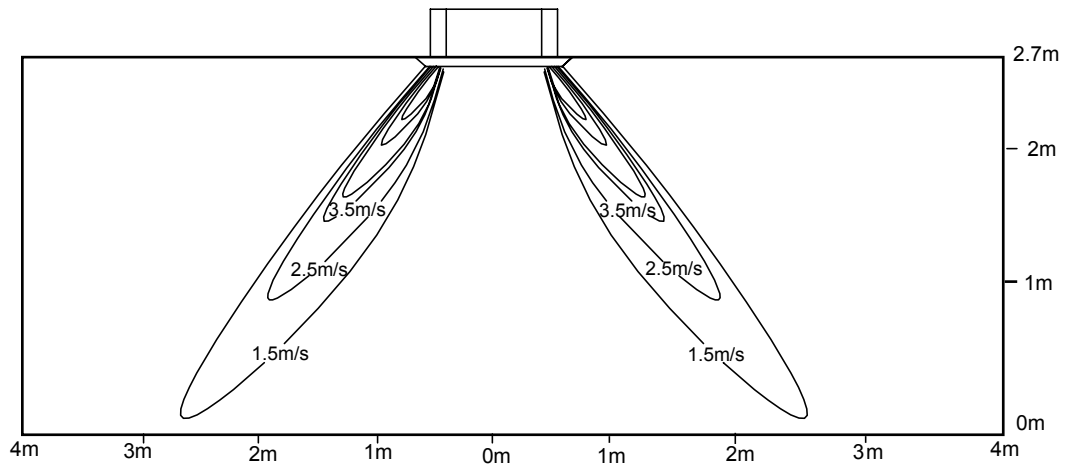

d. Heating/Temperature distribution

Heating

Blow angle: 60

Temperature distribution

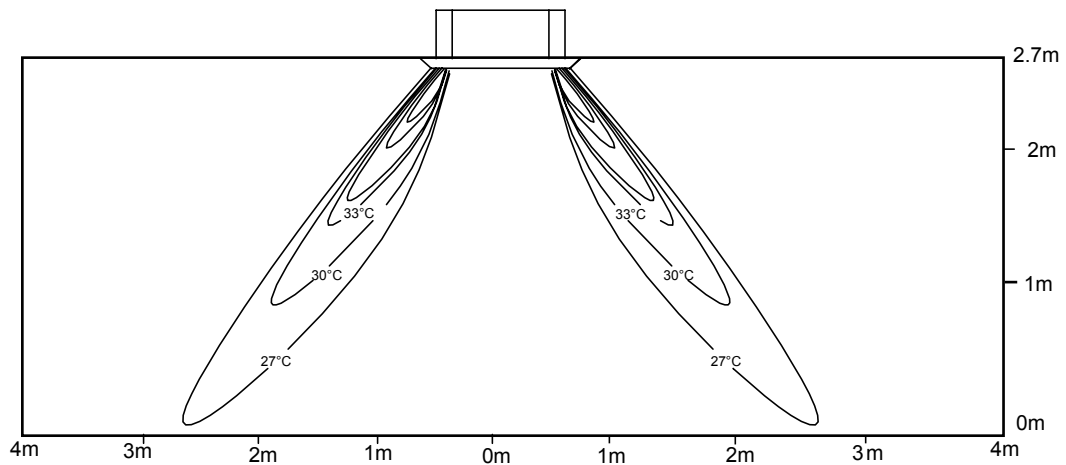

## 6. Sound pressure level

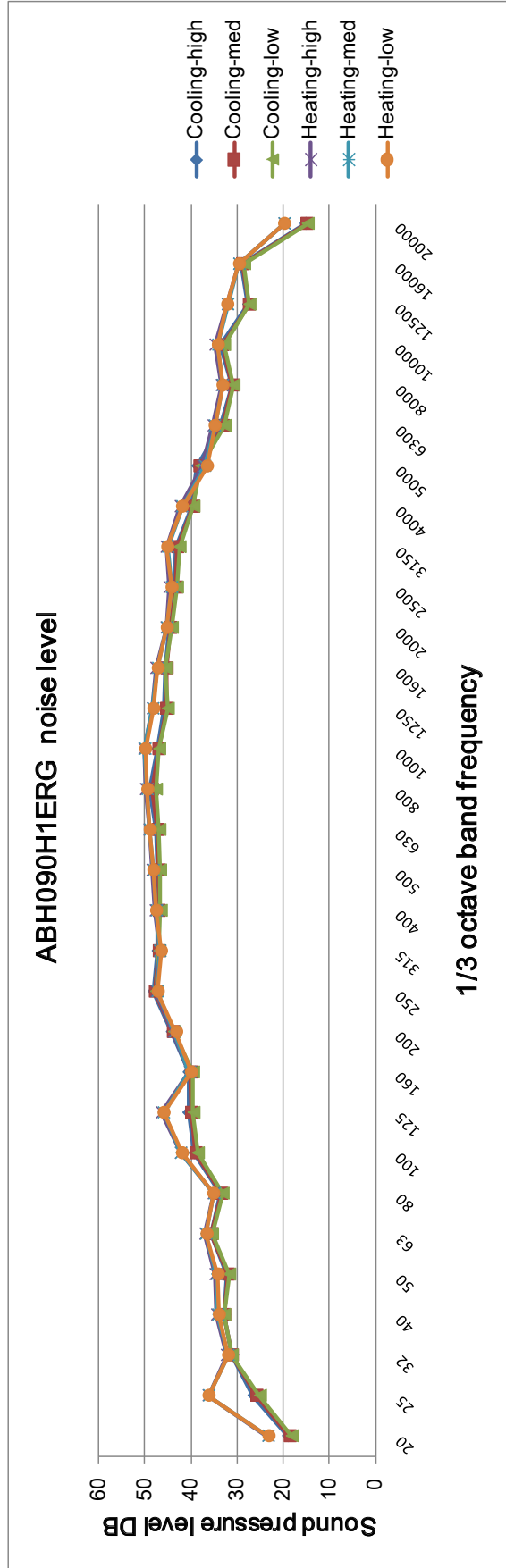
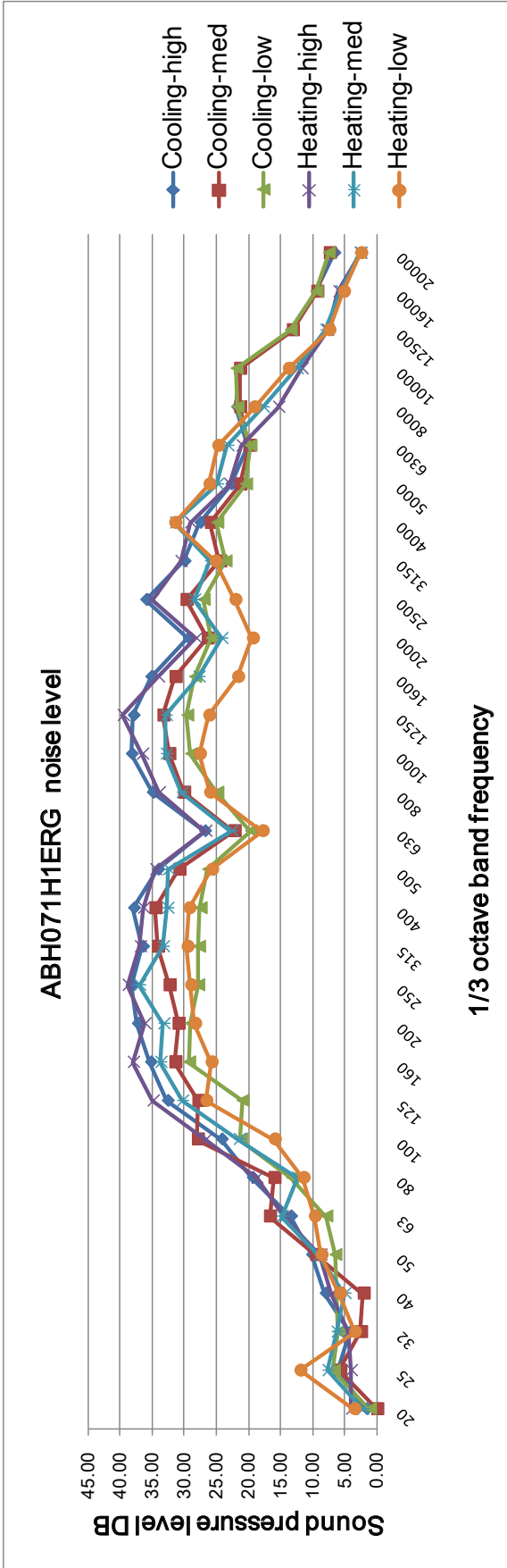

ABH105H1ERG noise level

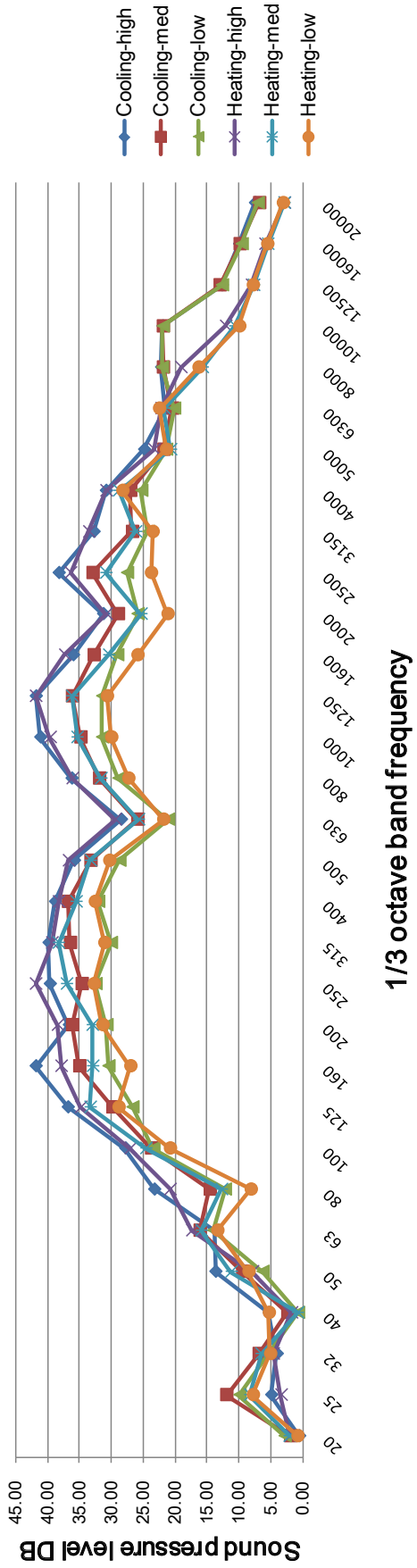

ABH125H1ERG noise level

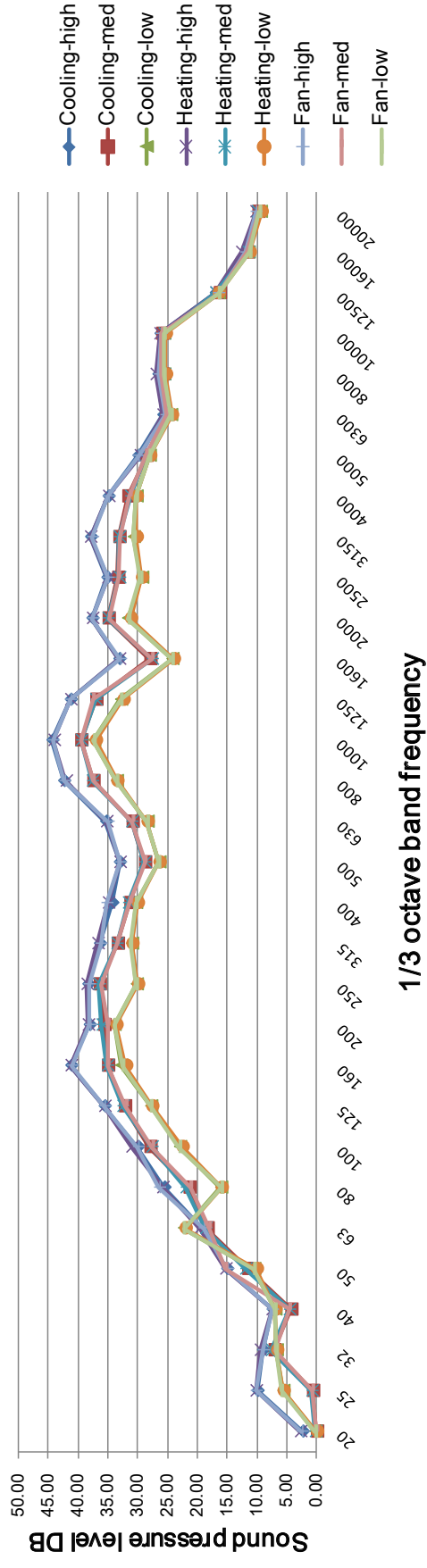

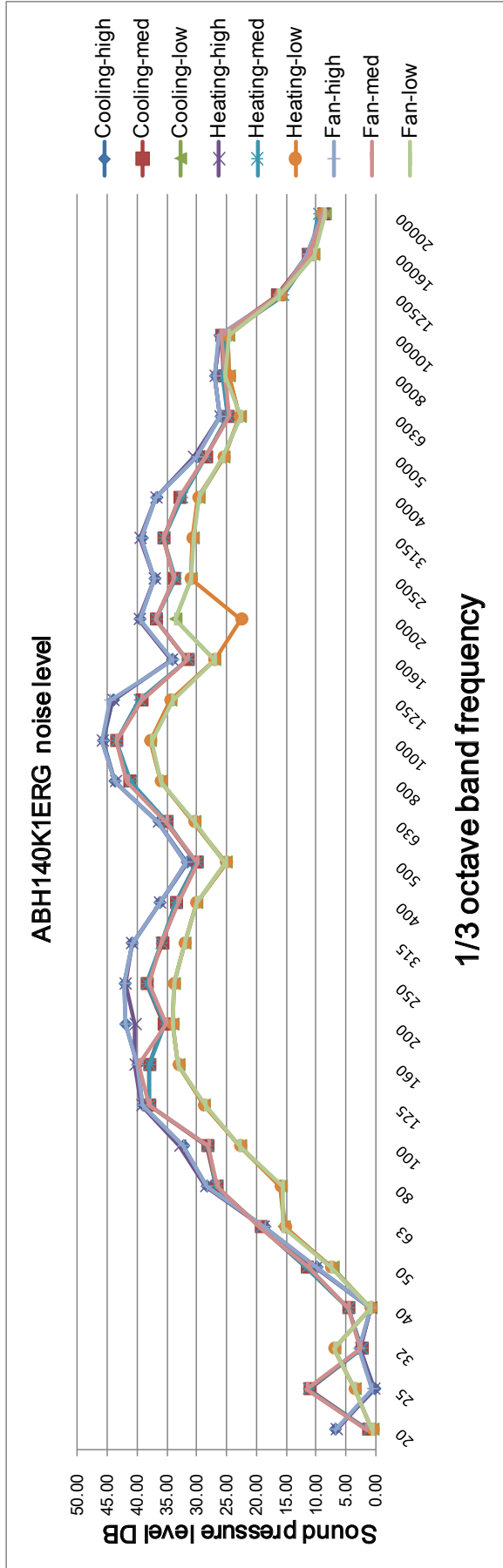

**7. Installation**

**7.1 Before installation** <Don't discard any accessories until comp>

- Determine the way to carry unit to installation place.
- Don't remove packing until unit reaches installation place.
- If unpacking is unavoidable, protect unit properly.

**7.2 Selection of installation place**

(1) Installation place shall meet the following and agreed by customers:

- Place where proper air flow can be ensured.
- No block to air flow.
- Water drainage is smooth.
- Place strong enough to support unit weight.
- Place where inclination is not evident on ceiling.
- Enough space for maintenance.
- Indoor and outdoor unit piping length is within limit. (Refer to Installation Manual for outdoor unit.)
- Indoor and outdoor unit, power cable, inter unit cable are at least 1 m away from T.V. radio. This is helpful to avoid picture disturbance and noise. (Even if 1 m is kept, noise can still appear if radio wave is strong)

(2) Ceiling height

Indoor unit can be installed on ceiling of 2.5-3m in height. (Refer to Field setting and Installation Manual of ornament panel.)

(3) Install suspending bolt.

Check if the installation place is strong enough to hold weight. Take necessary measures in case it is not safe.

(Distance between holes are marked on paper pattern. Refer to paper pattern for place need be reinforced)

(4) Selection of installation location of outdoor

With consent from the user, installation location shall:

- Be sufficient to bear weight of the units, with air circulation.
- Avoid direct radiation from heat sources or other heat sources.
- Facilitate the drainage of condensate. Holes in wall shall also facilitate drainage.
- Be such that noise and heat air will not disturb neighbors.
- Be free of heavy snow in winter.
- Allow air inlets and outlets to be free of barriers.
- Not allow air outlet to directly face strong airflow.
- Facilitate installation at four corners, with 1m space above the unit.
- Be convenient for maintenance and repair.
- For installation of multiple units, sufficient space shall be ensured to avoid short circuit.
- The air conditioner shall not be mounted on a non-dedicated metal frame (e.g. burglar mesh) .
- When the outdoor unit is installed on a street side, its height shall not be less than 2.5m.

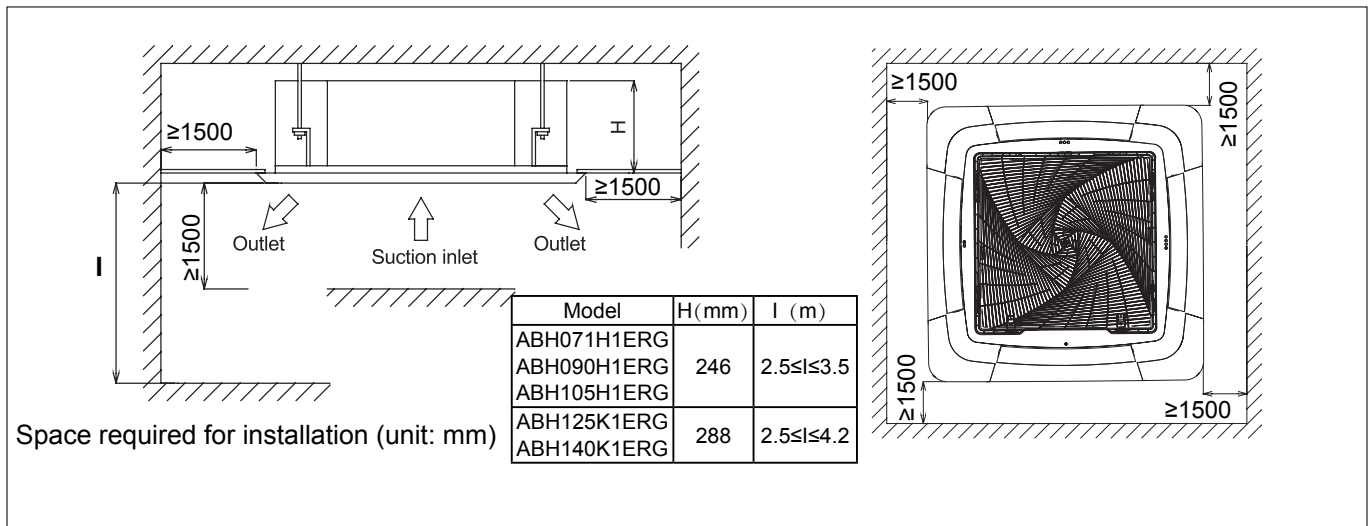

### 7.3 Preparation before installation

#### (1) Location relationships between ceiling opening and hanging screw

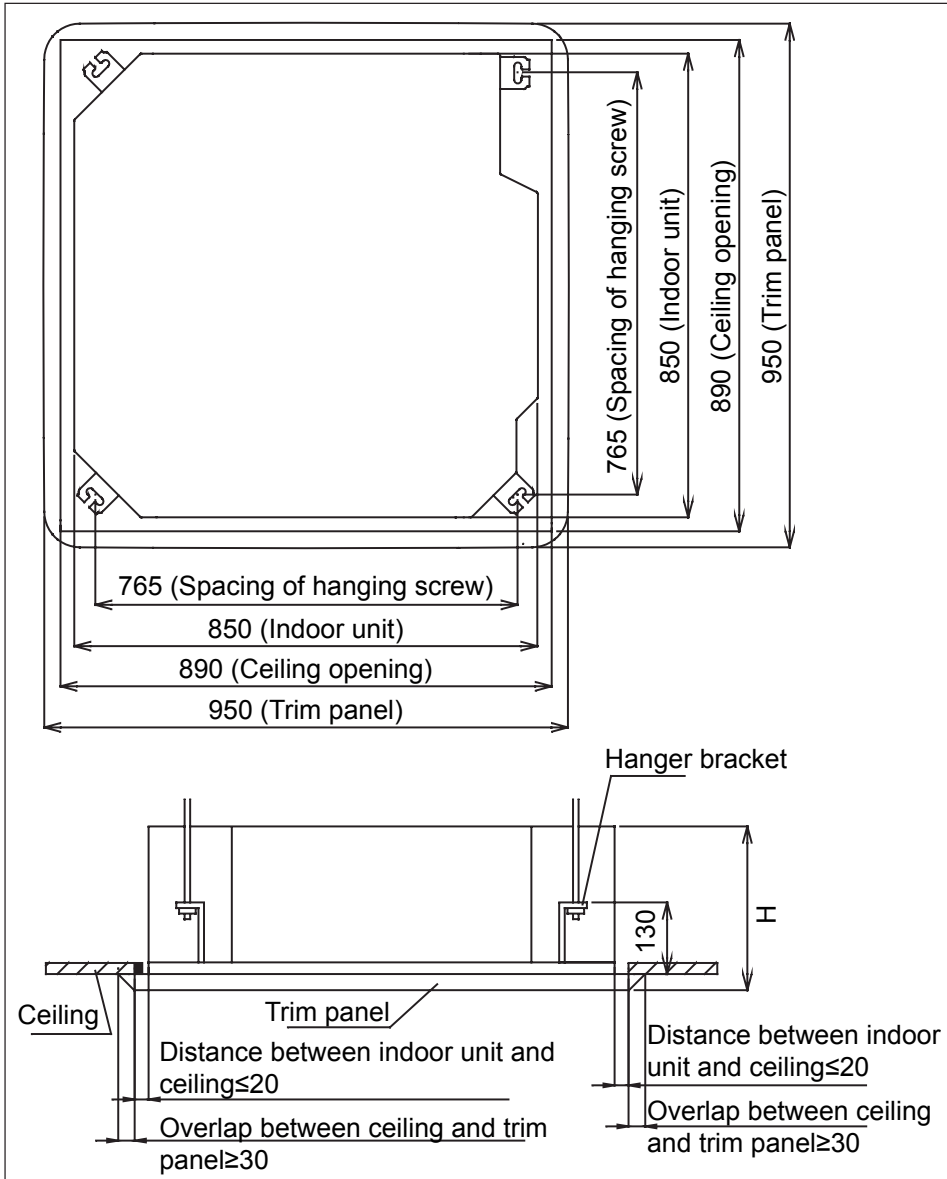

Model	H
ABH071H1ERG	299
ABH090H1ERG	
ABH105H1ERG	
ABH125K1ERG	341
ABH140K1ERG	

#### Note:

Overlap between the ceiling and decorative panel shall be 30mm or more. The distance between indoor unit and ceiling shall be 20mm or less. If it's more than 20mm, add ceiling materials at ■ or repair the ceiling.

(2) Complete all pipes (for refrigerants and drainage) and wires (for connection of indoor and outdoor units) to be connected to indoor unit before installation so that they can be connected to indoor unit immediately after installation.

(3) Install hanging screws

- To bearing the unit weight, use foundation bolts on existing ceilings, or embedded bolts, buried bolts or other parts that is provided on site on new ceilings. Before installation is continued, adjust the distance from ceiling.

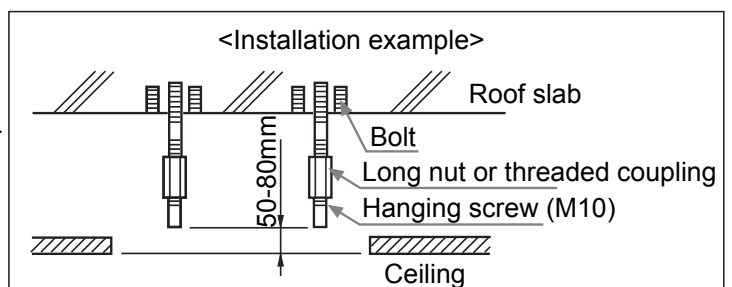

#### Note:

All the above parts are to be provided on installation sites. Diameter of hanging screws is M10.

**7.4 Installation of indoor unit**

Installation sequence on new ceiling: (1) → (3) → (4) → (5)

(1) Temporary installation of indoor unit

- Attach hangers to hanging screws, and make sure to use nuts and washers on both upper and lower ends of hangers so as to fix them firmly. A washer fixing plate (to be provided on site) can prevent the washer from dropping off.

<Work at ceilings>

(2) Adjust units to appropriate installation locations. Refer to "7.3 Preparation before installation."

(3) Correct levelness of air conditioner units.

- The indoor unit is equipped with a built-in drainage pump and a float switch. Correct levelness with a level or water-filled polyethylene pipe.

**Note:**

*If the unit inclines towards reverse direction of condensate flow, the float switch can not work normally and water leakage will be resulted.*

- (4) Pull out the original fixing plate that prevents the washer from dropping off, and tighten nuts.
- (5) Remove the installation cardboard.

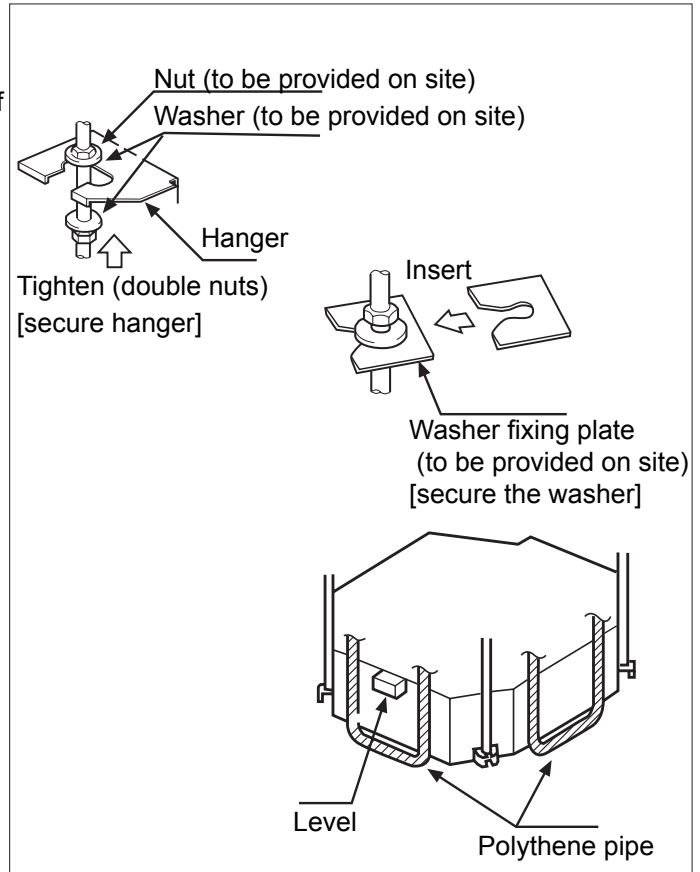

**7.5 Installation of drain pipe**

(1) Install drain pipe

- Diameter of the drain pipe shall be greater than or equal to that of the connecting pipe. (PE pipe: size: I.D.: 25mm; O.D.: 32mm)
- The drain pipe shall be short and have a downward slope of at least 1/100 to prevent pockets.
- If it is impossible to provide sufficient slope to the drain pipe, a drain lift pipe shall be installed.
- To avoid bending of the drain pipe, hangers shall be kept 1-1.5m away from each other.

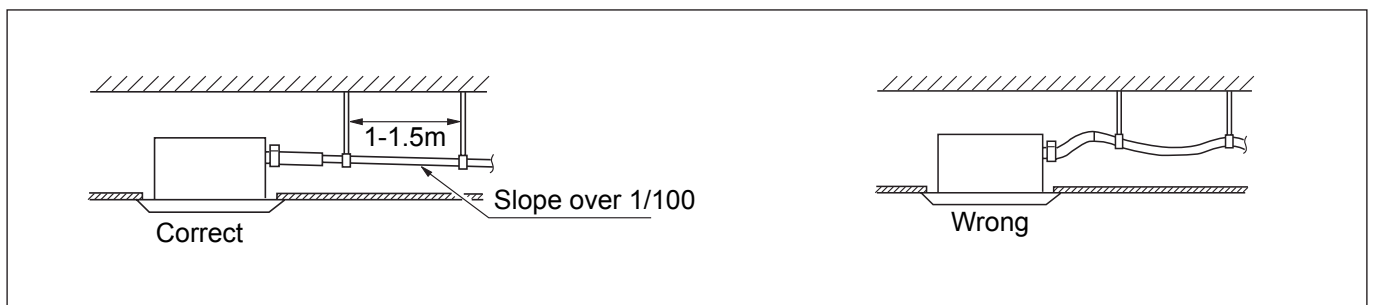

Use a drain hose and clamp.

Insert the drain hose into the drainage outlet until it reaches the white tape. Then tighten the clamp.

For heat insulation, wind the drain hose with sealing gaskets. Provide heat insulation to indoor drain hose.

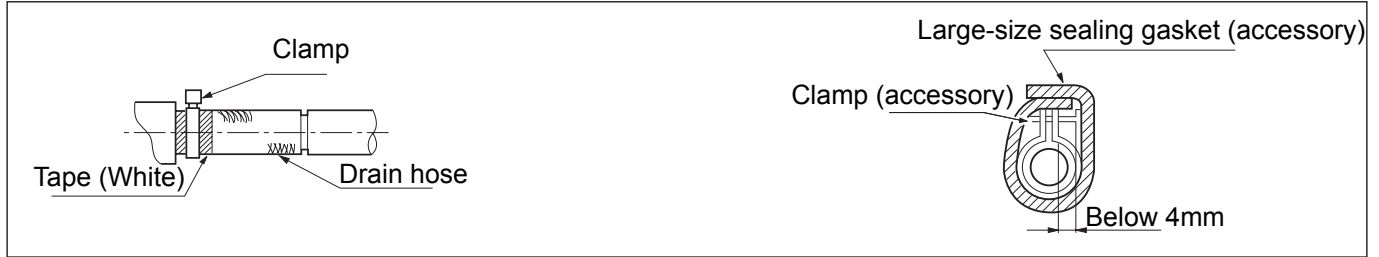

### <Precautions for drain lift pipe>

The drain lift pipe shall be installed as low as possible.

The drain lift pipe shall be perpendicular to the unit and not more than 300mm away from the unit.

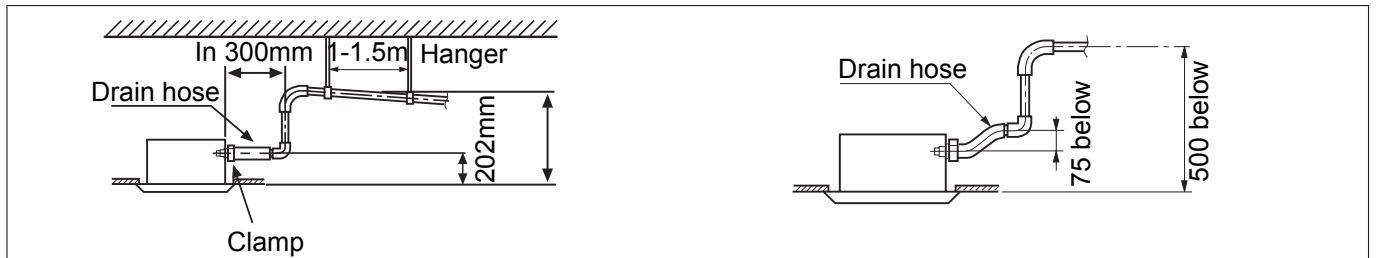

### Note:

- The slope of accessory drain pipe shall be within 75mm so that the drainage outlet does not necessarily bear excessive external force.
- If multiple drain pipes join together, install them as follows.

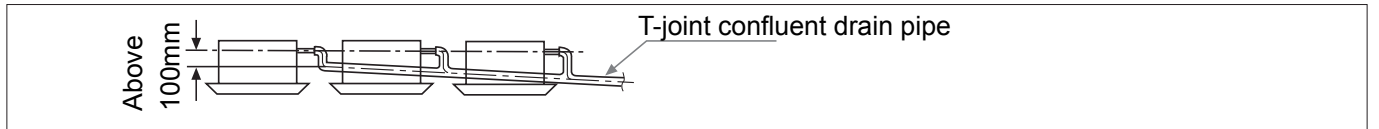

The size of confluent drain pipe selected shall be suitable for operating capacity of the units.

(2) Check drainage is smooth after installation.

- Check drainage by filling in 1200cc water slowly from air outlet or inspection hole.

## 7.6 Installation instruction for embedded air-conditioning panel

### 1. Before installation

### WARNING

The trim panel shall be put on buffer materials when unpacked to prevent being scratched by hard objects.

Please confirm the following accessories delivered with the product:

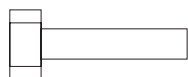

Bolt (M5\*25) Qty: 4



Gasket Qty: 4



Connect and fix the power supply cable, indoor-outdoor connection cable as following:

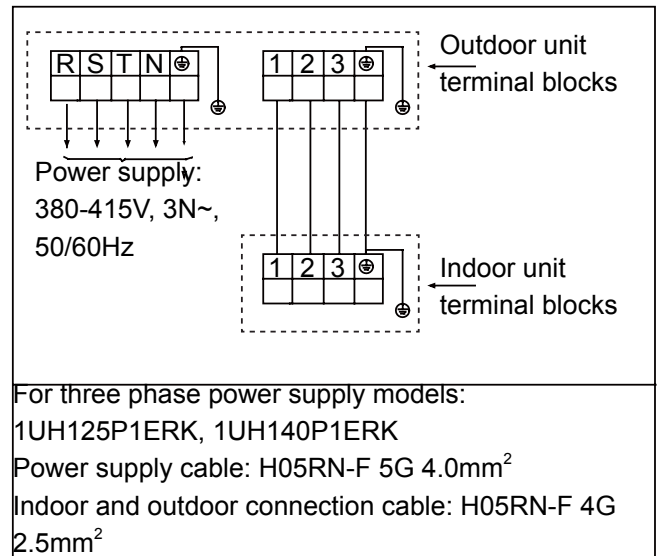
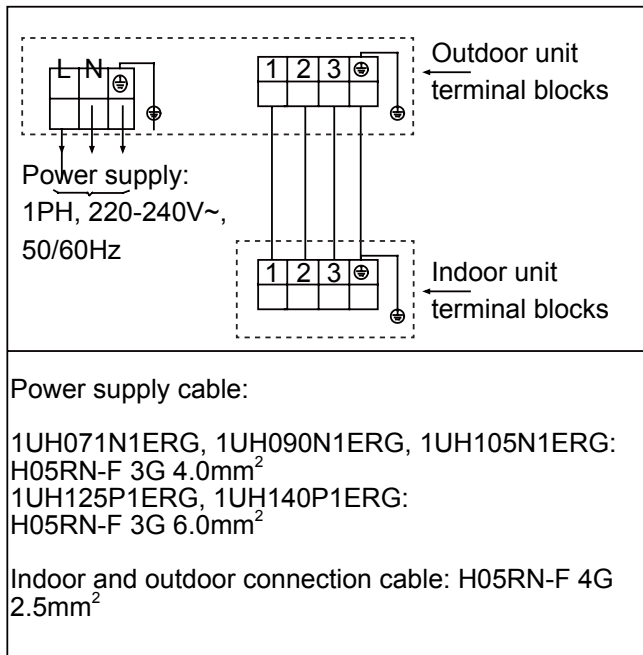

## 2. Installation

### (1) Confirming the position of unit hanger

Please confirm the installation position of the hanger for indoor unit is about 130mm above the ceiling. For details, please refer to the Instructions for Installation and Maintenance of indoor unit.

### (2) Removing the air-inlet grille

Open the air-inlet grille to make it at an angle of 45° to the trim panel. As shown in the following figure, please remove the air-inlet grille as per the operation requirements.

### (3) Installing the panel

- 1) Please remove the four (4) angle trim panels. Removal method: Flip the jack catches of the angle trim panel in the order of ①②③④, as shown in the following figure. The flipping direction is indicated by the arrows. Then the angle trim panel can be removed.
- 2) Pull out the two (2) U-shaped hooks on the indoor unit from below.
- 3) Adjust the panel direction to make the angle side engraved with "Pipe side" consistent with the refrigerant pipe of the indoor unit, and make the angle side engraved with "Drain side" consistent with the drain side of the indoor unit. Then hang the 2 hooks in the inner side of the panel on the 2 U-shaped hooks of the indoor unit.
- 4) Finally fix the panel on the indoor unit with the bolts (M5\*25) and gaskets delivered with the unit.  
Caution: Gaskets must be used for fixing, or else the panel would be easy to fall off.
- 5) When tightening the four (4) bolts, please make sure there is no clearance between the panel fixing seat on the side of the indoor unit and the panel fixing seat on the side of the panel. That is to say: the bolts shall be fully tightened (see \* in the figure). If there is a clearance, air leakage or water leakage is likely to occur.

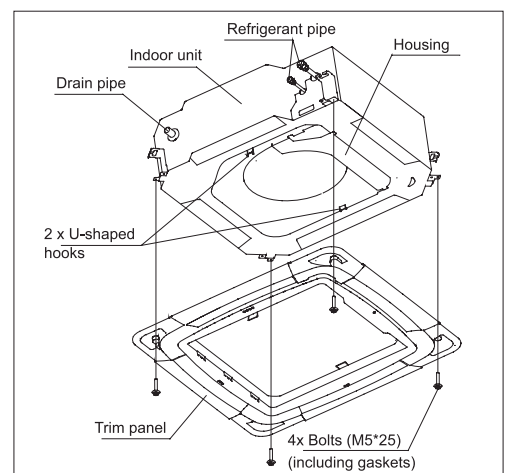
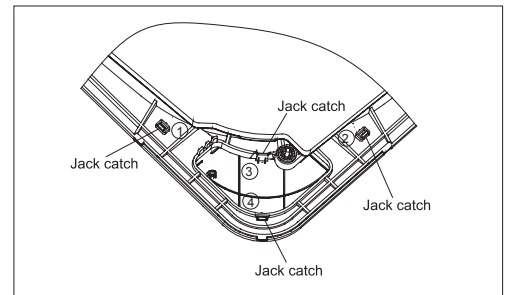
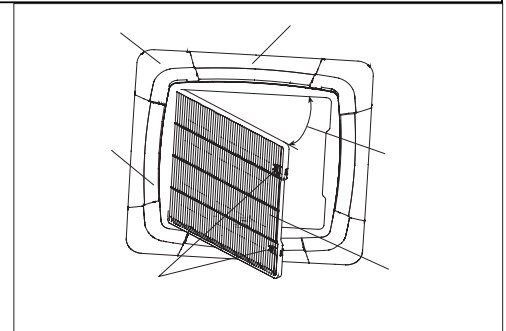

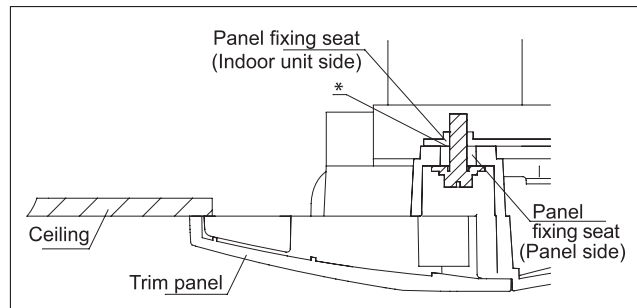

## ⚠ CAUTION

- Improper tightening of bolts would lead to the faults shown in the following figure.
- After tightening the bolts, if there is a clearance between the ceiling and the trim panel, please readjust the height of the indoor unit.

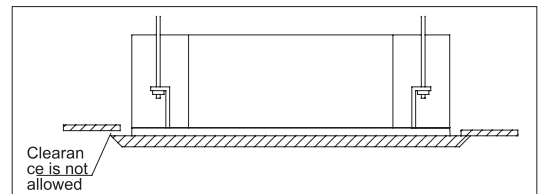
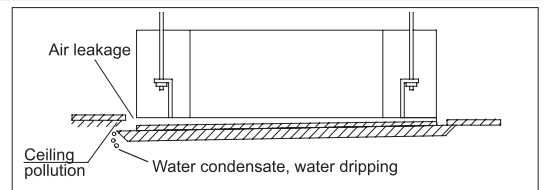

If the elevation level of the indoor unit and drain pipe are not affected, you can adjust the height of the indoor unit through the corner pore on the trim panel. Please keep the unit horizontal in the process of adjustment, or else water leakage is easy to occur.

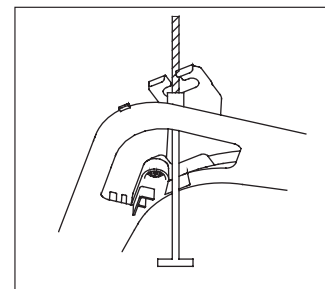

- Please do not swing the louver blade by hand, or else the blade mechanism would be damaged.
- 6) Connection of trim panel. Connect the black lead-out terminal of the panel to the black lead-out terminal of the indoor unit housing.

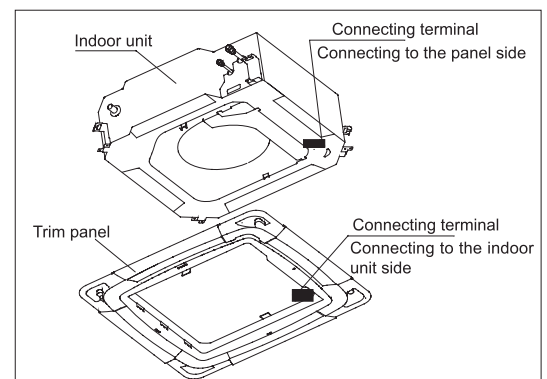

- 7) When the installation of panel is complete, please fix the four (4) angle trim panels.
- Hang and tighten the strap of the angle trim panel on the shackle of the trim panel, as shown in the figure.
  - Fix the angle trim panel on the trim panel.

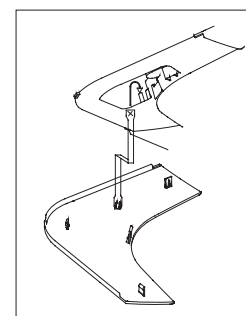

## 8) Installing the air-inlet grille.

Install the air-inlet grille with the steps opposite to that for removing.

For reference

The method for removing angle trim panels when the installation of trim panel is complete:

- 1) Insert a straight screwdriver in the notch ①. Gently turn the screwdriver downward, and slowly insert it in, and then move it up and down to make the angle fall off.
- 2) Make the angle ② and ③ fall off in the same way.
- 3) Take off the angle trim panel by hand.

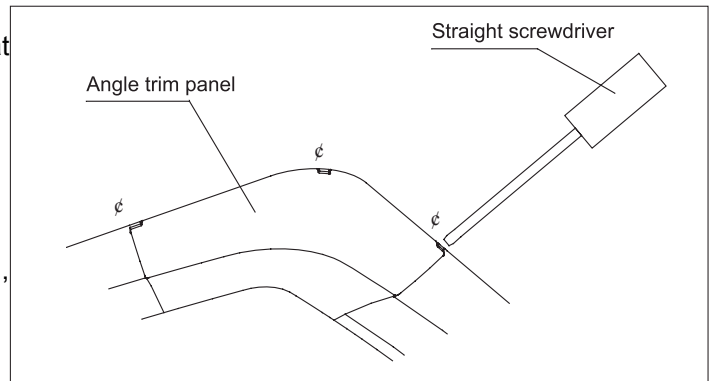

## 8. Test run

### 8.1 Check items

#### 1. Indoor unit

- Is operation of each button on the remote control unit normal?
- Does each lamp light normally?
- Do not air flow direction louvers operate normally?
- Is the drain normal?

#### 2. Outdoor unit

- Is there any abnormal noise and vibration during operation?
- Will noise, wind, or drain water from the unit disturb the neighbors?
- Is there any gas leakage?

#### Customer guidance

Explain the following to the customer in accordance with the operation manual:

- (1) Starting and stopping method, operation switching, temperature adjustment, timer, air flow switching, and other remote control unit operations.
- (2) Air filter removal and cleaning, and how to use air louvers.
- (3) Give the operation and installation manuals to the customer.

### 8.2 Test run

#### WARNING

This unit will be started instantly without "ON" operation when electric power is supplied. Be sure to execute "OFF" operation before electric power is disconnected for servicing.

- This unit has a function of automatic restart system after recovering power stoppage

#### 1. Before starting test run (for Heat pump models)

Confirm whether the power source breaker (main switch) of the unit has been turned on for over 12 hrs to energize the crankcase heater in advance of operation.

#### 2. Test run

- Run the unit continuously for about 30 minutes, and check the following. Suction pressure at check joint of service valve for gas pipe.
- Discharge pressure at check joint on the compressor discharge pipe.
- Temperature difference between return air and supply air for indoor unit.

## Part 3 Indoor Units-Medium ESP duct type

1. Feature .....	31
2. Specification .....	33
3. Dimension .....	39
4. Wiring diagram .....	41
5. Air velocity and temperature distribution .....	43
6. Installation .....	

**1. Feature**

**High Efficiency**

**DC fan motor**

Haier duct adopts DC fan motor, compared to conventional AC fan motor, DC fan motor is more efficiency.

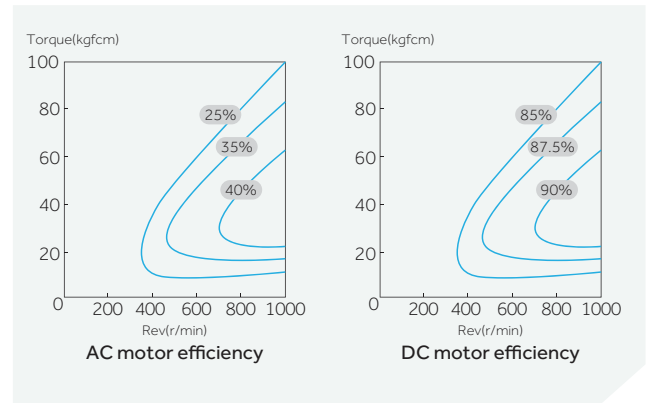

**Comfortable**

**Consistent airflow**

The indoor units contain up to 3 fans which can provide consistent airflow in different ESP enhancing the comfort.

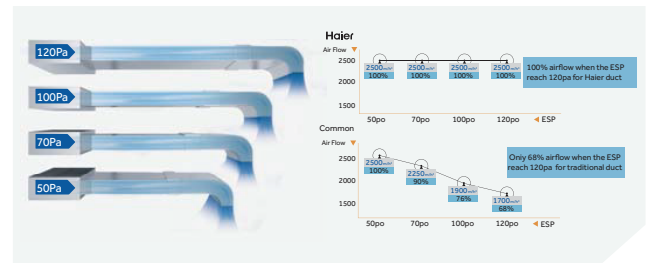

**Flexible Design**

**Super slim**

250mm of thickness for better installation application flexibility.

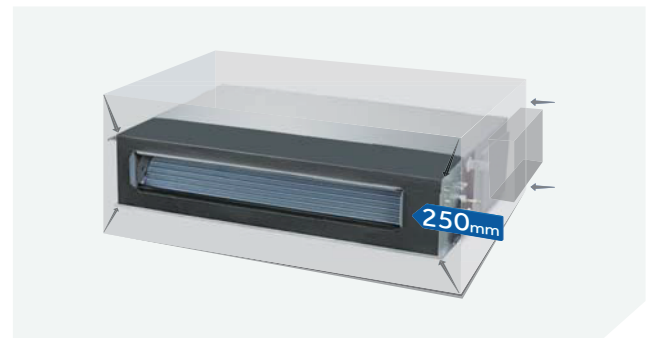

**Return air choices**

Friendly design: Rear air return or bottom air return is available.



### High lift-up drain pump

It can lift condensed water up to 750mm, which make installation more flexible according to the layout.

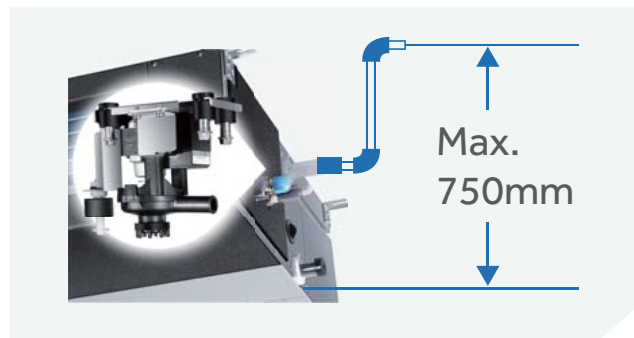

### Adjustable E.S.P control

Because of the DC fan motor, the duct unit can adjust E.S.P :10/30/50/70Pa(7.1kW,8.2kW), 30~120Pa (10,12.5,14kW) by the wired controller, it can optimise air duct work installation, maintain airflow and sound levels as required.

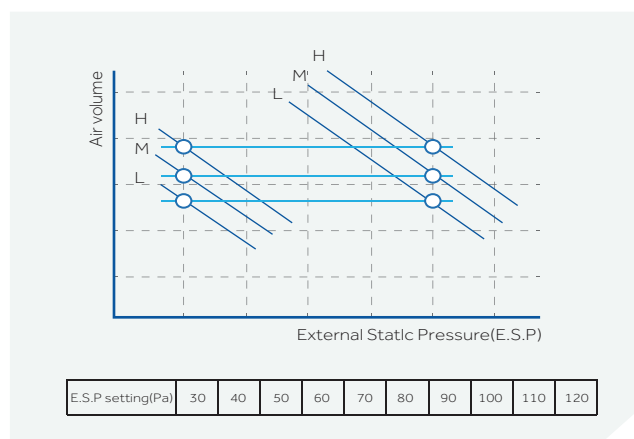

2. Specification

Item		Model	ADH071M1ERG/1UH071N1ERG				
Function			Cooling	Heating			
Capacity		kW	7.1 (2.0~9.0)	8 (2.0~10.0)			
Sensible heat ratio			0.72	/			
Total power input		kW	2.03 (0.4~4.0)	2.0 (0.4~4.0)			
Max. power input		W	4000	4000			
AEER or ACOP		W/W	3.41	3.89			
Dehumidifying capacity		10 <sup>-3</sup> ×m <sup>3</sup> /h	2.5				
Power cable			4.0mm <sup>2</sup>				
Power source		N, V, Hz	1, 220-240, 50/60				
Running/Max. Running current		A/A	8.8 (2.0-17.5) /17.5	9.2 (2.0-17.5) /17.5			
Start current		A	3				
Circuit breaker		A	40	40			
Indoor unit	Unit model (color)		ADH071M1ERG				
	Fan	Type×Number	CENTRIFUGALX2				
		Speed (H-M-L)	r/min	950/860/760			
		Fan motor output/ input power	W	85/111			
		Air-flow (H-M-L)	m <sup>3</sup> /h	1050/840/630			
		External static pressure	Pa	10/30(default)/50/70			
	Heat exchanger	Type / Diameter	mm	inner grooved pipe/φ7.0			
		Row		3			
		Total area	m <sup>2</sup>	7.668			
	Dimension	External (L×W×H)	mm×mm×mm	957/655/250			
		Package (L×W×H)	mm×mm×mm	1170/860/340			
	Drainage pipe (material, I.D./O.D.)		mm	PVC 25/29			
	Controller (O-Optional, S-Standard)		Wired	YR-E16A(O)/YR-E17(S)			
			Infrared	YR-HBS01(O)			
	Fresh air hole dimension		mm	145			
	Electricity heater		kW	/			
Sound power noise level (H)		dB (A)	58				
Sound pressure noise level (H-M-L)		dB (A)	38/35/32				
Weight (Net/Shipping)		kg / kg	31.2/36.8				
Piping	Refrigerant	Type / Charge	g	R410A/2500			
		Recharge quantity	g/m	45			
	Pipe	Liquid	m	9.52			
		Gas	mm	15.88			
		Max.pipe lengh without charge refrigerant	mm	20			
	Between I.D & O.D	MAX.Drop	m	30			
		MAX.Piping length	m	50			
Connecting method			Flared				
Cooling	Pdesignc (kW):	7.1Kw	SEER/CLASS	6.3/A++	QCE(Annual electricity consumption for cooling)kWh:	390	
Heating	Average	Pdesignh (-10°C)	6.0Kw	SCOP/CLASS	4.2/A+	QHE(Annual electricity consumption for heating)kWh:	1982
	Warmer	Pdesignh (2°C)	6.0Kw	SCOP/CLASS	4.8/A++		1652
	Colder	Pdesignh (-22°C)	/	SCOP/CLASS	/	/	
Tdesignh: -10°C		Tbivalent: -10°C	TOL: -15°C		Elbu: 0		
Max. cooling condition	Indoor temperature: 32°C/23°C		Max. heating condition	Indoor temperature: 27°C/-°C			
	Outdoor temperature: 46°C/-°C			Outdoor temperature: 24C/18C			
Norminal condition:							
Indoor temperature (cooling) : 27DB (°C)/19WB (°C) , Indoor temperature (heating) : 20DB (°C)							
Outdoor temperature (cooling) : 35DB (°C)/24WB (°C) , Outdoor temperature (heating) : 7DB (°C)/6WB (°C)							
The noise level will be measured in the third octave band limited values, using a Real Time Analyser calibrated sound intensity meter. It is a sound pressure noise level.							

Item		Model	ADH090M1ERG/1UH090N1ERG		
Function			Cooling	Heating	
Capacity		kW	8.5 (2.5~10)	9.5 (2.5~11)	
Sensible heat ratio			0.72	/	
Total power input		kW	2.50 (0.5~4.4)	2.50 (0.5~4.4)	
Max. power input		W	4400	4400	
AEER or ACOP		W/W	3.33	3.72	
Dehumidifying capacity		10 <sup>-3</sup> ×m <sup>3</sup> /h	2.5		
Power cable			4.0mm <sup>2</sup>		
Power source		N, V, Hz	1, 220-240, 50/60		
Running/Max. Running current		A/A	11.1 (2.3-19.2) /19.2	11.1 (2.3-19.2) /19.2	
Start current		A	3		
Circuit breaker		A	40	40	
Indoor unit	Unit model (color)		ADH090M1ERG		
	Fan	Type×Number	CENTRIFUGALX2		
		Speed (H-M-L)	r/min	1020/920/820	
		Fan motor output/ input power	W	112/147	
		Air-flow (H-M-L)	m <sup>3</sup> /h	1300/900/700	
		External static pressure	Pa	10/30(default)/50/70	
	Heat exchanger	Type/Diameter	mm	inner grooved pipe/φ7.0	
		Row		3	
		Total area	m <sup>2</sup>	/	
	Dimension	External (L×W×H)	mm×mm×mm	957/655/250	
		Package (L×W×H)	mm×mm×mm	1170/860/340	
	Drainage pipe (material, I.D./O.D.)		mm	PVC 25/29	
	Controller (O-Optional, S-Standard)		Wired	YR-E16A(O)/YR-E17(S)	
			Infrared	YR-HBS01(O)	
Fresh air hole dimension		mm	145		
Electricity heater		kW	NONE		
Sound power noise level (H)		dB (A)	60		
Sound pressure noise level (H-M-L)		dB (A)	40/37/34		
Piping	Refrigerant	Type / Charge	g	R410A/2500	
		Recharge quantity	g/m	45	
	Pipe	Liquid	mm	9.52	
		Gas	mm	15.88	
		Max.pipe length without charge refrigerant	m	20	
	Between I.D & O.D	MAX.Drop	m	30	
		MAX.Piping length	m	50	
Connecting method			Flared		

Cooling	Pdesignc (kW):	8.5kW	SEER/CLASS	6.1/A++	QCE(Annual electricity consumption for cooling)kWh:	485	
Heating	Average	Pdesignh (-10°C)	7.0kW	SCOP/CLASS	4.1/A+	QHE(Annual electricity consumption for heating)kWh:	2256
	Warmer	Pdesignh (2°C)	7.8kW	SCOP/CLASS	4.8/A++		1928
	Colder	Pdesignh (-22°C)	/	SCOP/CLASS	/	/	/
Tdesignh: -10°C		Tbivalent: -10°C	TOL: -15°C		Elbu: 0		
Max. cooling condition	Indoor temperature: 32°C/23°C		Max. heating condition		Indoor temperature: 27°C/-°C		
	Outdoor temperature: 46°C/-°C				Outdoor temperature: 24C/18C		

Norminal condition:

Indoor temperature (cooling) : 27DB (°C)/19WB (°C) , Indoor temperature (heating) : 20DB (°C)

Outdoor temperature (cooling) : 35DB (°C)/24WB (°C) , Outdoor temperature (heating) : 7DB (°C)/6WB (°C)

The noise level will be measured in the third octave band limited values, using a Real Time Analyser calibrated sound intensity meter. It is a sound pressure noise level.



Item		Model	ADH105M1ERG/1UH105N1ERG		
Function			Cooling	Heating	
Capacity		kW	10 (2.5~11)	10.4 (2.5~12)	
Sensible heat ratio			0.72	/	
Total power input		kW	2.93(0.5~4.5)	2.97 (0.5~4.5)	
Max. power input		W	5000	5000	
AEER or ACOP		W/W	3.37	3.46	
Dehumidifying capacity		10 <sup>-3</sup> ×m <sup>3</sup> /h	3.2		
Power cable			4.0mm <sup>2</sup>		
Power source		N, V, Hz	1, 220~240, 50/60		
Running/Max. Running current		A/A	13.3 (2.3-19.0) /21.0	13.5 (2.3-19.0) /21.0	
Start current		A	3		
Circuit breaker		A	40		
Indoor unit	Unit model (color)		ADH105M1ERG		
	Fan	Type×Number	CENTRIFUGALX3		
		Speed (H-M-L)	r/min	1050/950/850	
		Fan motor output/ input power	kW	0.16/0.2	
		Air-flow (H-M-L)	m <sup>3</sup> /h	2000/1740/1380/1280	
		External static pressure	Pa	30-120	
	Heat exchanger	Type/Diameter	mm	inner grooved pipe/φ7.0	
		Total area	m <sup>2</sup>	/	
	Dimension	External (L×W×H)	mm×mm×mm	1500/700/250	
		Package (L×W×H)	mm×mm×mm	1710/865/320	
	Drainage pipe (material, I.D./O.D.)		mm	PVC 26/32	
	Controller (O-Optional, S-Standard)		Wired	YR-E16A(O)/YR-E17(S)	
			Infrared	YR-HBS01 (O)	
	Fresh air hole dimension		mm	100	
	Electricity heater		kW	/	
Sound power Noise level (H)		dB (A)	55		
Sound pressure Noise level (H)		dB (A)	32/28/25/23		
Weight (Net / Shipping)		kg / kg	49/61		
Piping	Refrigerant	Type / Charge	g	R410A/2500	
		Recharge quantity	g/m	45	
	Pipe	Liquid	mm	9.52	
		Gas	mm	15.88	
		Max.pipe length without charge refrigerant		20	
	Between I.D&O.D	MAX.Drop	m	30	
		MAX.Piping length	m	50	
Connecting method			Flared		

Cooling	Pdesignc (kW):	10kW	SEER/CLASS	6.7/A++	QCE(Annual electricity consumption for cooling)kWh:	548
Heating	Average	Pdesignh (-10°C)	9.7kW	SCOP/CLASS	4.0/A+	3624
	Warmer	Pdesignh (2°C)	10.2kW	SCOP/CLASS	4.8/A++	2976
	Colder	Pdesignh (-22°C)	/	SCOP/CLASS	/	/
Tdesignh: -10°C		Tbivalent: -10°C	TOL: -15°C		Elbu: 0	
Max. cooling condition	Indoor temperature: 32°C/23°C		Max. heating condition	Indoor temperature: 27°C/-°C		
	Outdoor temperature: 46°C/-°C			Outdoor temperature: 24C/18C		

Norminal condition:

Indoor temperature (cooling) : 27DB (°C)/19WB (°C) , Indoor temperature (heating) : 20DB (°C)

Outdoor temperature (cooling) : 35DB (°C)/24WB (°C) , Outdoor temperature (heating) : 7DB (°C)/6WB (°C)

The noise level will be measured in the third octave band limited values, using a Real Time Analyser calibrated sound intensity meter. It is a sound pressure noise level.

Item		Model	ADH125M1ERG/1UH125P1ERG		
Function			Cooling	Heating	
Capacity		kW	12.5 (3.5~15.0)	13.7(4~18.0)	
Sensible heat ratio			0.74	/	
Total power input		kW	3.67 (1.0~6.5)	3.91 (1.0~6.5)	
Max. power input		W	6500	6500	
AEER or ACOP		W/W	3.37	3.47	
Dehumidifying capacity		10 <sup>-3</sup> ×m <sup>3</sup> /h	4.9		
Power cable			6.0mm <sup>2</sup>		
Power source		N, V, Hz	1ph, 220~240, 50/60		
Running/Max. Running current		A/A	17.0 (8.7-30.0) /30A	17.5 (8.7-30.0) /30A	
Start current		A	3		
Circuit breaker		A	40		
Indoor unit	Unit model (color)		ADH125M1ERG		
	Fan	Type×Number		CENTRIFUGALX3	
		Speed (H-M-L)		r/min	
		Fan motor output power/input power		kW	
		Air-flow(H-M-L)		m <sup>3</sup> /h	
		ESP		Pa	
	Heat exchanger	Type/Diameter		mm	
		Total area		m <sup>2</sup>	
	Dimension	External	(L×W×H)	mm×mm×mm	
		Package	(L×W×H)	mm×mm×mm	
	Drainage pipe (material, I.D./O.D.)		mm	PVC 26/32	
	Controller (O-Optional, S-Standard)		Wired	YR-E17 (S)/YR-E16A(O)	
			Infrared	YR-HBS01 (O)	
	Fresh air hole dimension		mm	125	
	Electricity heater		kW	/	
Sound power Noise level (H)		dB (A)	62		
Sound pressure Noise level (H-M-L)		dB (A)	39/36/33/31		
Weight (Net / Shipping)		kg / kg	52/62		
Piping	Refrigerant	Type / Charge		g	
		Recharge quantity		g/m	
	Pipe	Liquid		mm	
		Gas		mm	
		Max.pipe lengh without charge refrigerant		m	
	Between I.D&O.D	MAX.Drop		m	
		MAX.Piping length		m	
Connecting method			Flared		
<p>Norminal condition:</p> <p>Indoor temperature (cooling) : 27DB (°C)/19WB (°C) , Indoor temperature (heating) : 20DB (°C)</p> <p>Outdoor temperature (cooling) : 35DB (°C)/24WB (°C) , Outdoor temperature (heating) : 7DB (°C)/6WB (°C)</p> <p>The noise level will be measured in the third octave band limited values, using a Real Time Analyser calibrated sound intensity meter. It is a sound pressure noise level.</p>					

Item		Model	ADH125M1ERG/1UH125P1ERK		
Function			Cooling	Heating	
Capacity		kW	12.5 (3.5~15.0)	13.7(4~18.0)	
Sensible heat ratio			0.74	/	
Total power input		kW	3.67 (1.0~6.5)	3.91 (1.0~6.5)	
Max. power input		W	7000	7000	
AEER or ACOP		W/W	3.37	3.47	
Dehumidifying capacity		10 <sup>-3</sup> ×m <sup>3</sup> /h	4.9		
Power cable			4.0mm <sup>2</sup>		
Power source		N, V, Hz	3, 380~415, 50/60		
Running/Max. Running current		A/A	6.1/10.8	6.5/10.8	
Start current		A	3		
Circuit breaker		A	40		
Indoor unit	Unit model (color)		ADH125M1ERG		
	Fan	Type×Number		CENTRIFUGALX3	
		Speed (H-M-L)		r/min	
		Fan motor input power/output power		kW	
		Air-flow (H-M-L)		m <sup>3</sup> /h	
		ESP		Pa	
	Heat exchanger	Type/Diameter		mm	
		Total area		m <sup>2</sup>	
	Dimension	External (L×W×H)		mm×mm×mm	
		Package (L×W×H)		mm×mm×mm	
	Drainage pipe (material, I.D./O.D.)		mm	PVC 26/32	
	Controller (O-Optional, S-Standard)		Wired	YR-E17(S)/YR-E16A(O)	
			Infrared	YR-HBS01 (O)	
	Fresh air hole dimension		mm	125	
	Electricity heater		kW	/	
Sound power Noise level (H)		dB (A)	62		
Sound pressure Noise level (H-M-L)		dB (A)	39/36/33/31		
Weight (Net / Shipping)		kg / kg	52/62		
Piping	Refrigerant	Type / Charge		R410A/3700	
		Recharge quantity		g/m	
	Pipe	Liquid		mm	
		Gas		mm	
	Max.pipe length without charge refrigerant		m	30	
	Between I.D&O.D	MAX.Drop		m	
MAX.Piping length		m			
Connecting method		Flared			

Norminal condition:

Indoor temperature (cooling) : 27DB (°C)/19WB (°C) , Indoor temperature (heating) : 20DB (°C)

Outdoor temperature (cooling) : 35DB (°C)/24WB (°C) , Outdoor temperature (heating) : 7DB (°C)/6WB (°C)

The noise level will be measured in the third octave band limited values, using a Real Time Analyser calibrated sound intensity meter. It is a sound pressure noise level.

Item		Model	ADH140M1ERG/1UH140P1ERK		
Function			Cooling	Heating	
Capacity		kW	13.4 (3.5~15.5)	15.0 (4.0~19.0)	
Sensible heat ratio			0.74	/	
Total power input		kW	4.05	4.29	
Max. power input		W	7200	7200	
AEER or ACOP		W/W	3.28	3.47	
Dehumidifying capacity		10 <sup>-3</sup> ×m <sup>3</sup> /h	5.2		
Power cable			4.0mm <sup>2</sup>		
Power source		N, V, Hz	3,380~415, 50/60		
Running/Max. Running current		A/A	6.8(2.9-10.5)/11.0	7.0(2.9-10.5)/11.0	
Start current		A	3		
Circuit breaker		A	40		
Indoor unit	Unit model (color)		ADH140M1ERG		
	Fan	Type×Number		CENTRIFUGALX3	
		Speed (H-M-L)		r/min	1250/1120/900
		Fan motor input power/output power		kW	0.32/0.4
		Air-flow (H-M-L)		m <sup>3</sup> /h	2500/2160/1780
		ESP		Pa	30-120
	Heat exchanger	Type/Diameter		inner grooved pipe/φ7.0	
		Total area		m <sup>2</sup>	
	Dimension	External (L×W×H)		mm×mm×mm	
		Package (L×W×H)		mm×mm×mm	
	Drainage pipe (material, I.D./O.D.)		mm	PVC 26/32	
	Controller (O-Optional, S-Standard)		Wired	YR-E17(S)/YR-E16A (O)	
			Infrared	YR-HBS01 (O)	
	Fresh air hole dimension		mm	125	
	Electricity heater		kW	/	
	Sound power Noise level (H)		dB (A)	64	
Sound pressure Noise level (H-M-L)		dB (A)	41/36/33		
Weight (Net / Shipping)		kg / kg	52/63		
Piping	Refrigerant	Type / Charge		R410A/3700	
		Recharge quantity		g/m	
	Pipe	Liquid		mm	
		Gas		mm	
		Max.pipe length without charge refrigerant		m	
	Between I.D&O.D	MAX.Drop		m	
		MAX.Piping length		m	
Connecting method			Flared		

Normal condition:

Indoor temperature (cooling) : 27DB (°C)/19WB (°C) , Indoor temperature (heating) : 20DB (°C)

Outdoor temperature (cooling) : 35DB (°C)/24WB (°C) , Outdoor temperature (heating) : 7DB (°C)/6WB (°C)

The noise level will be measured in the third octave band limited values, using a Real Time Analyser calibrated sound intensity meter. It is a sound pressure noise level.

3. Dimension

3.1 ADH071M1ERG ADH090M1ERG

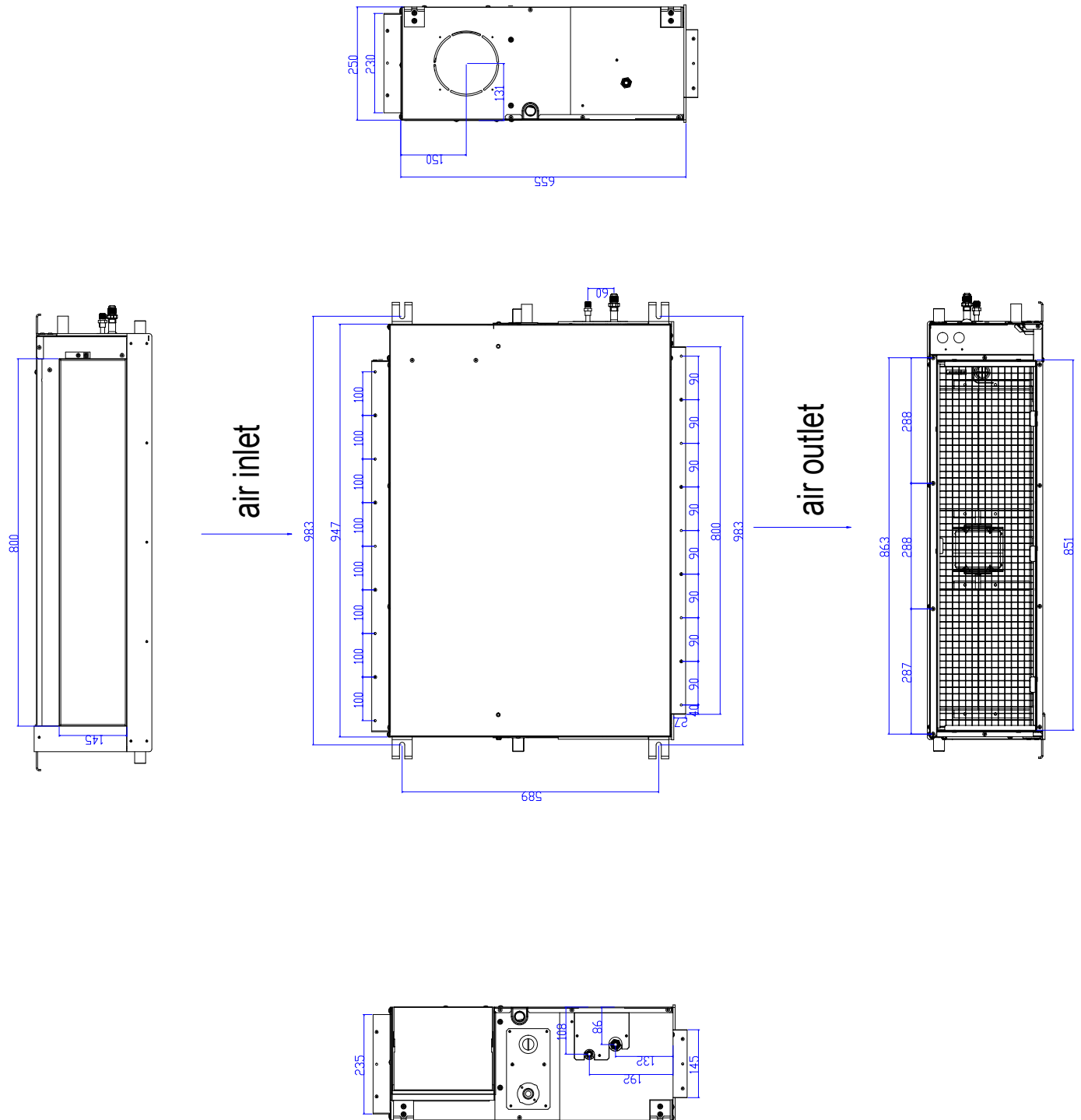

## 3.2 ADH105M1ERG AD1H125M1ERG ADH140M1ERG

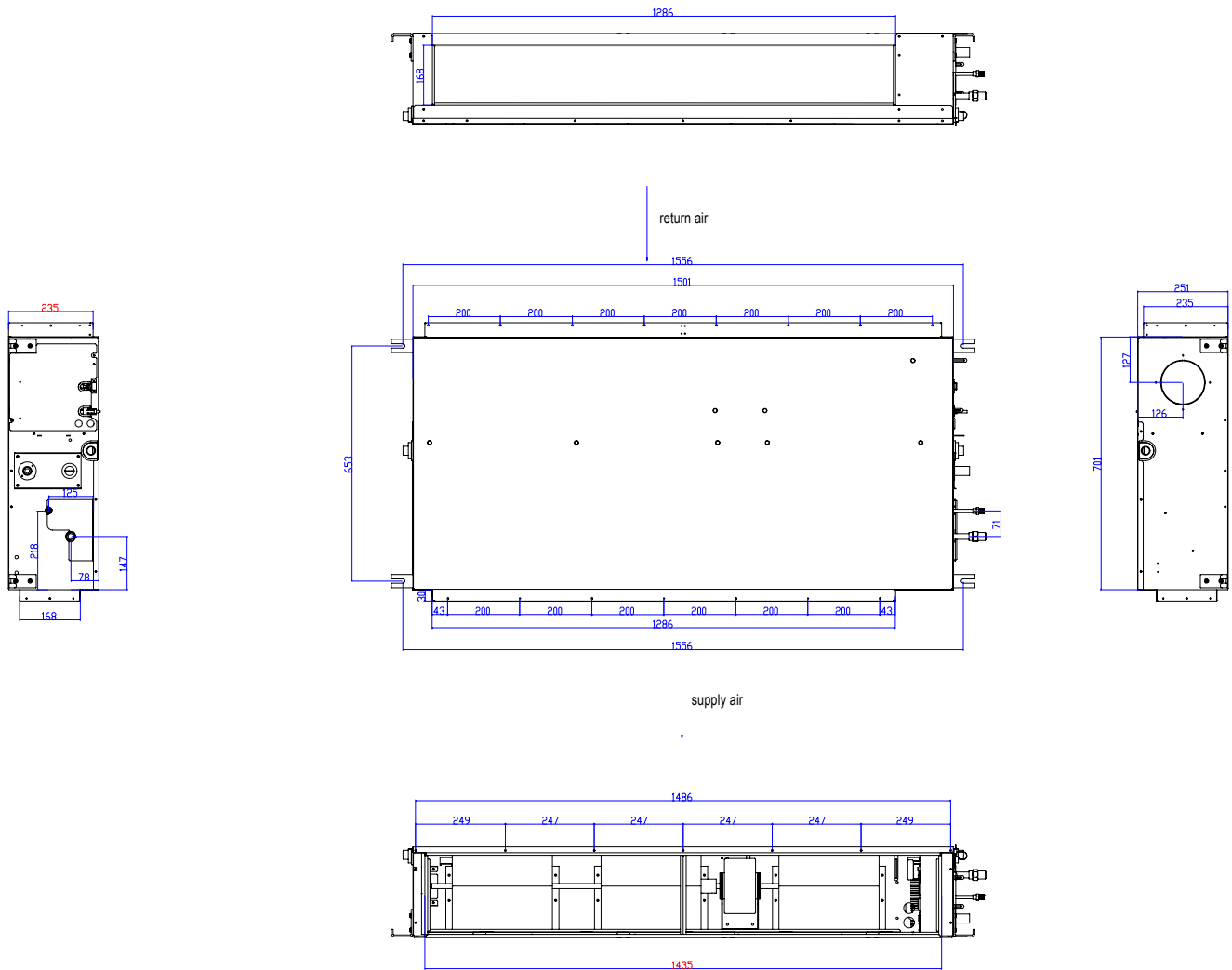

4. Wiring diagram

ADH071M1ERG ADH090M1ERG

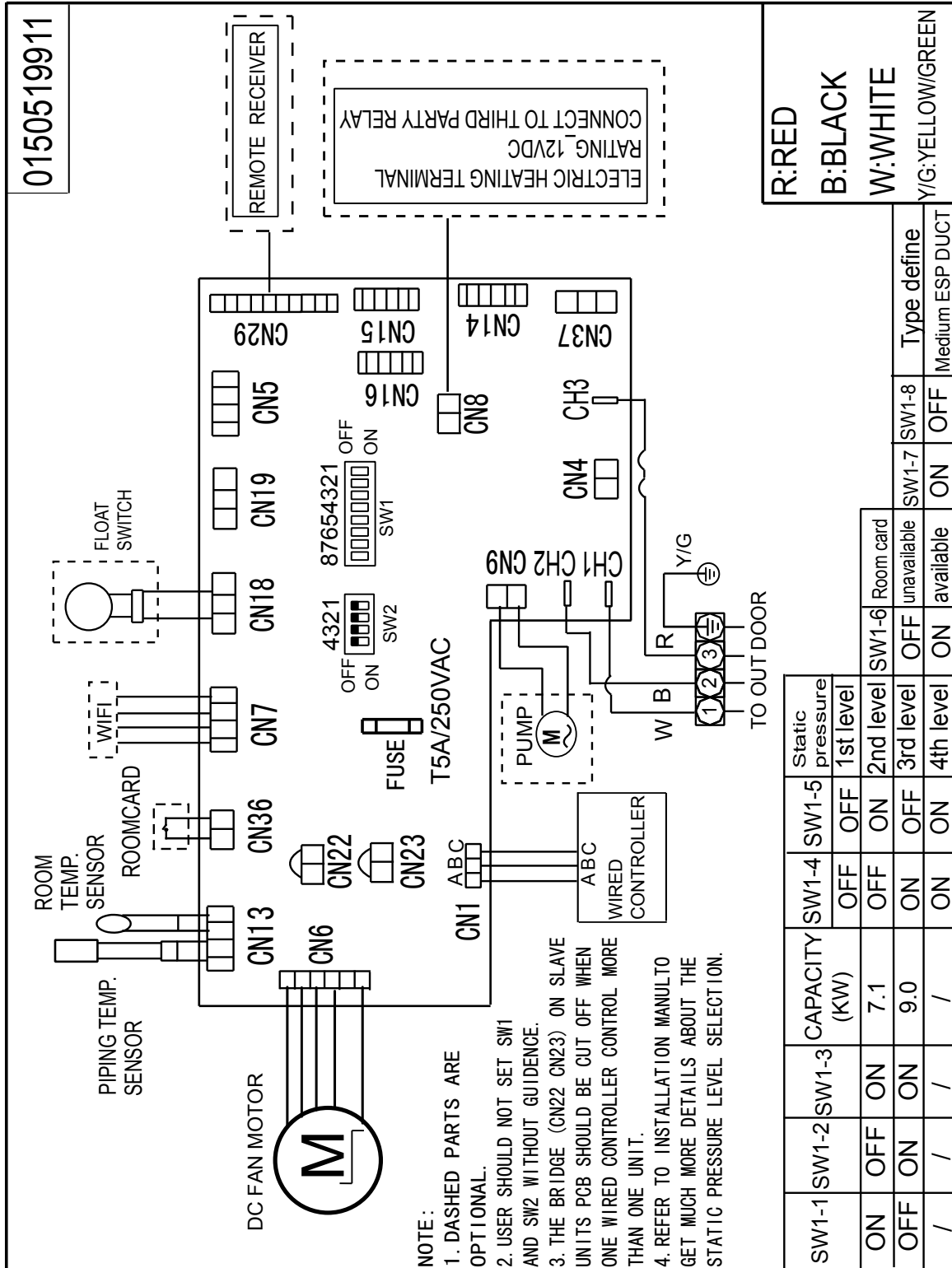

## ADH105&125&140M1ERG

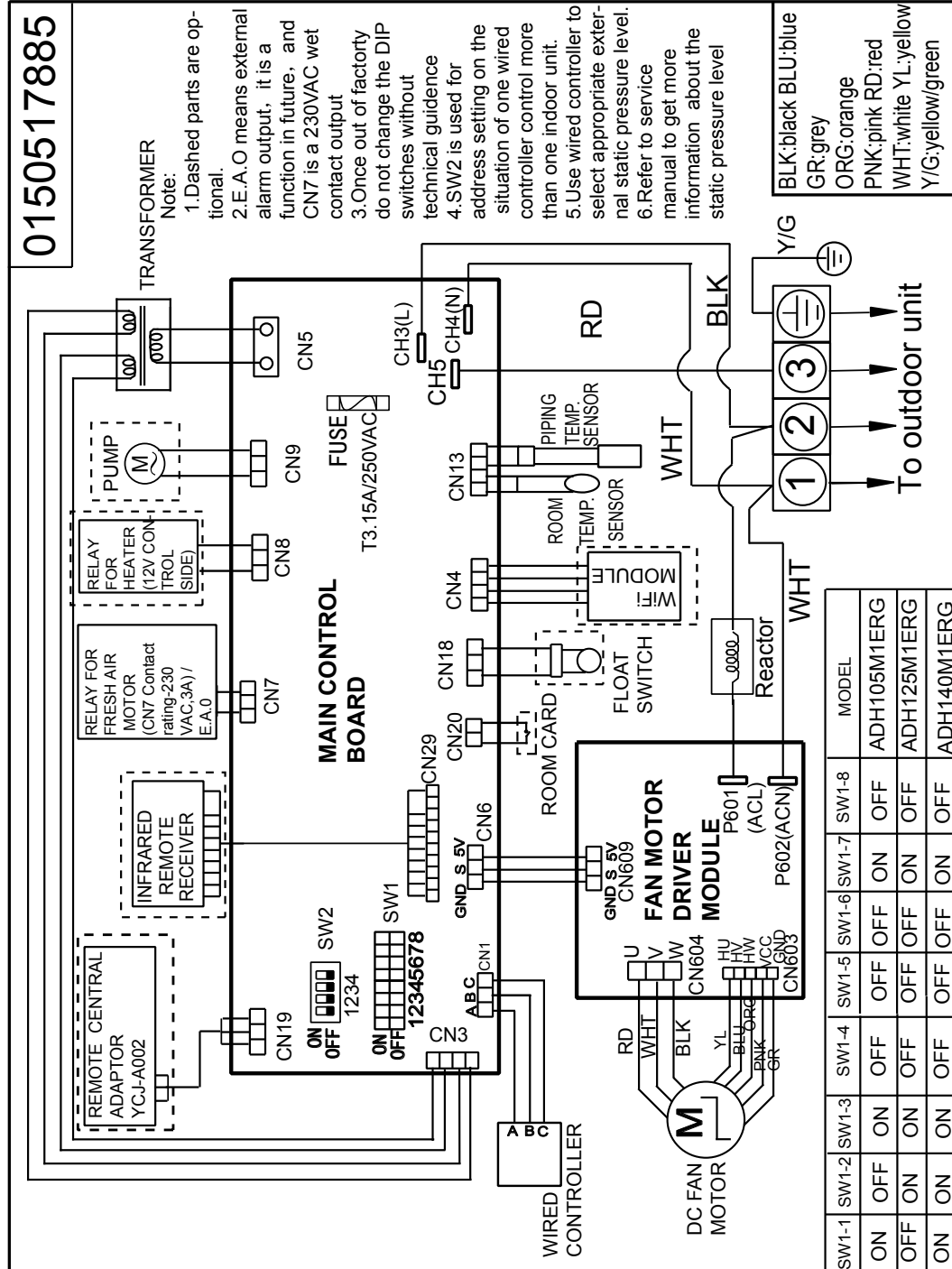



5. Airflow and Static Pressure Chart

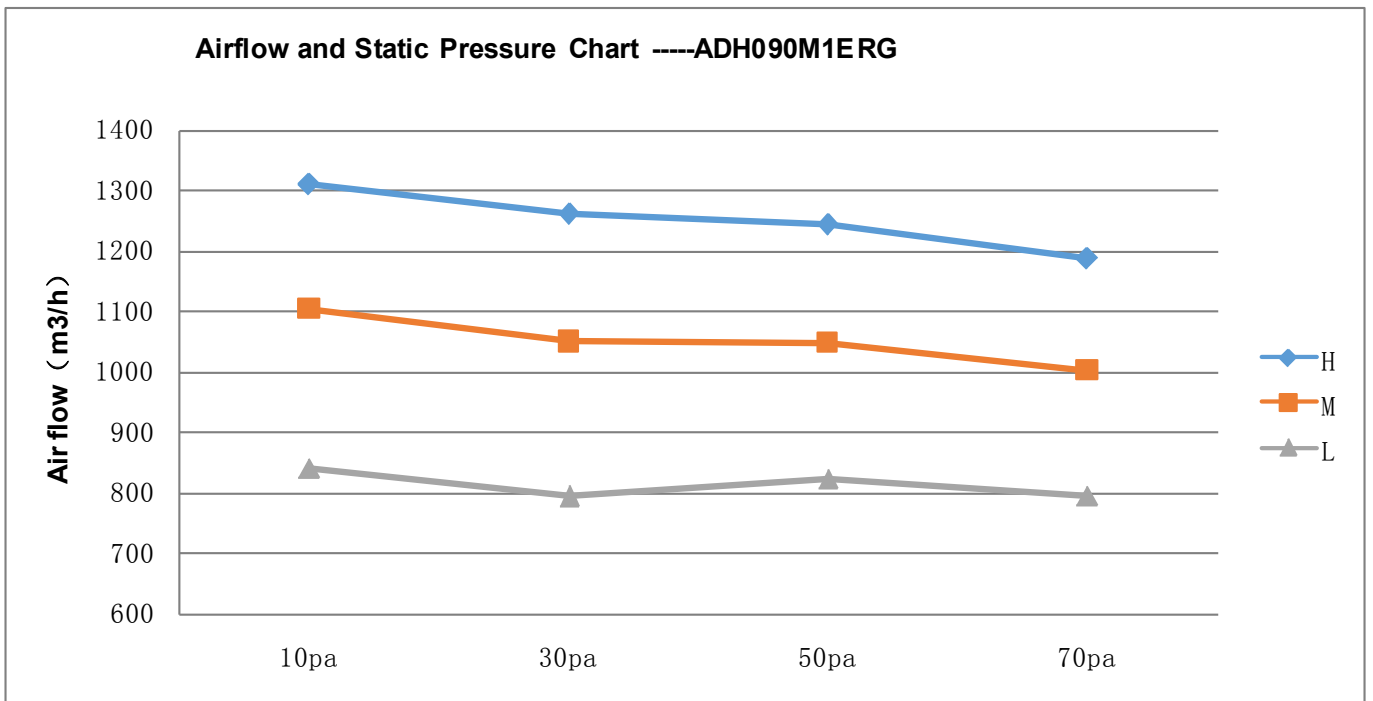
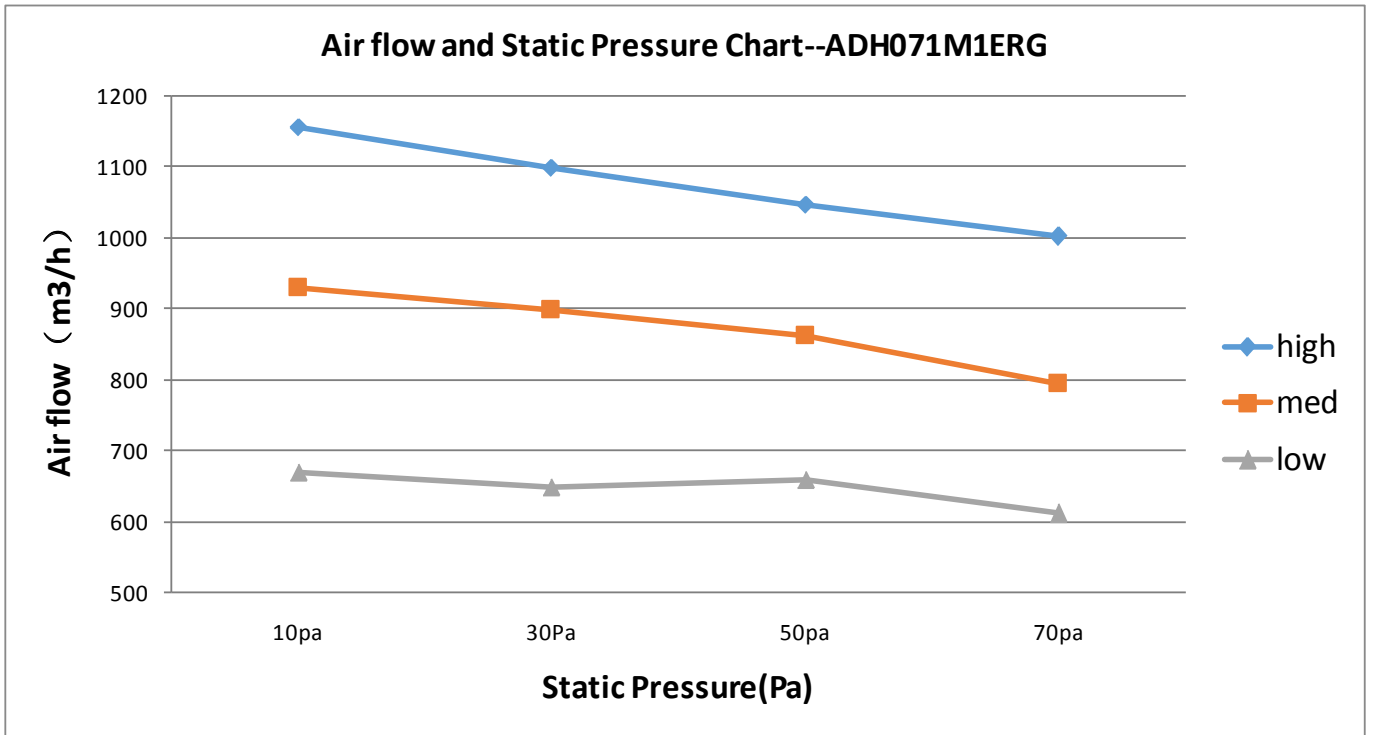

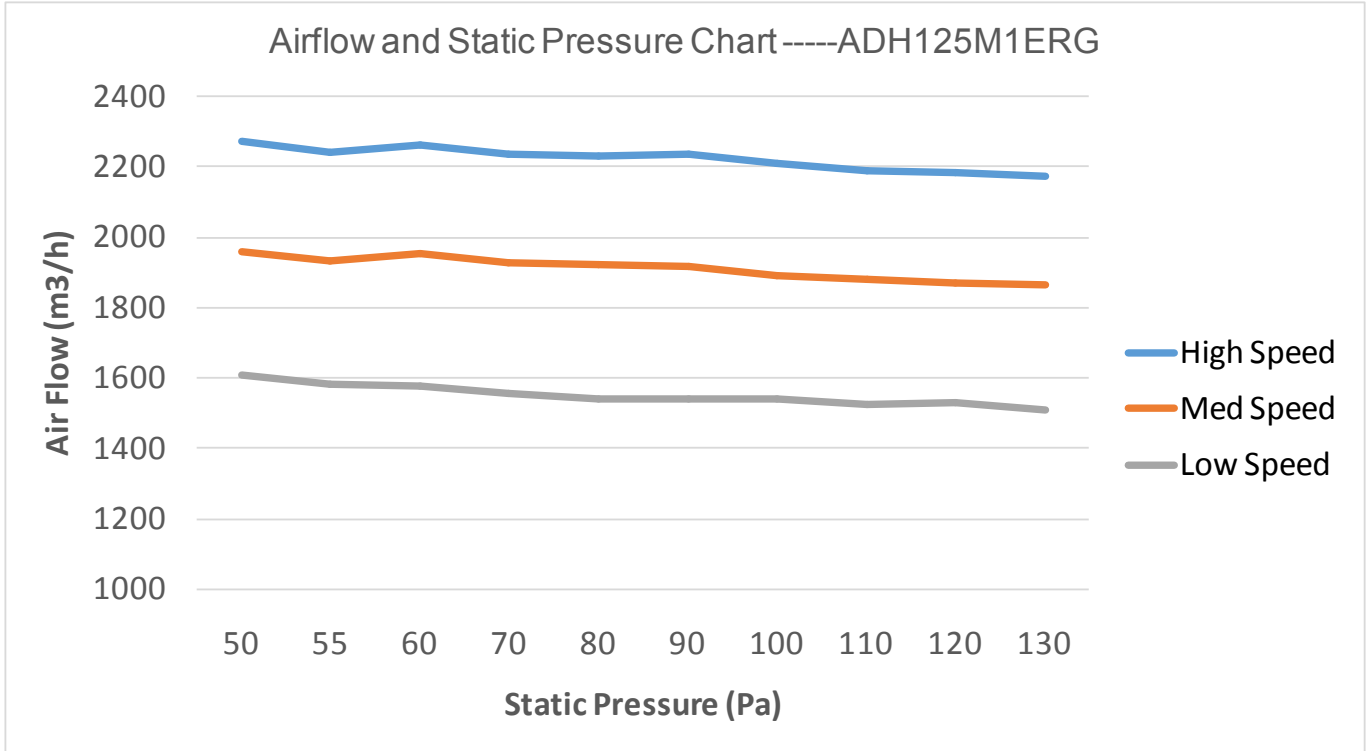
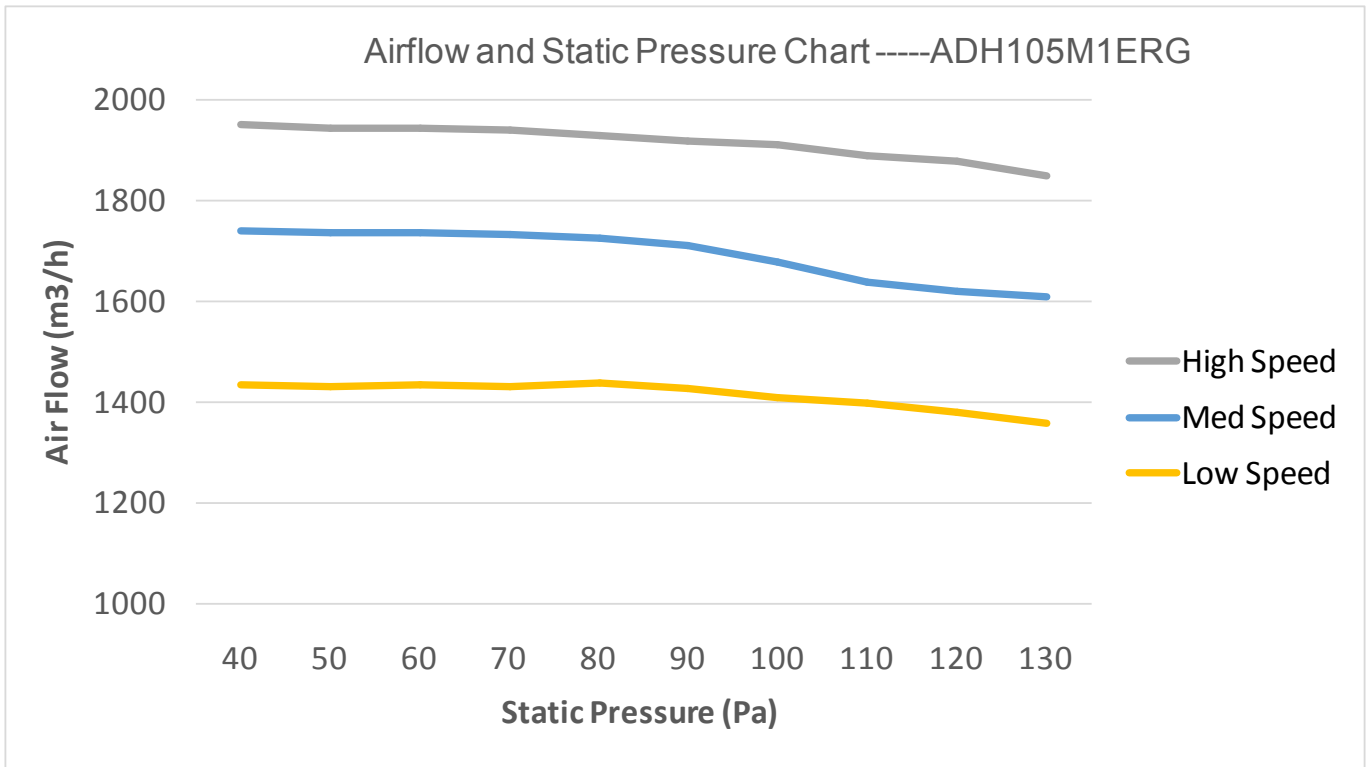

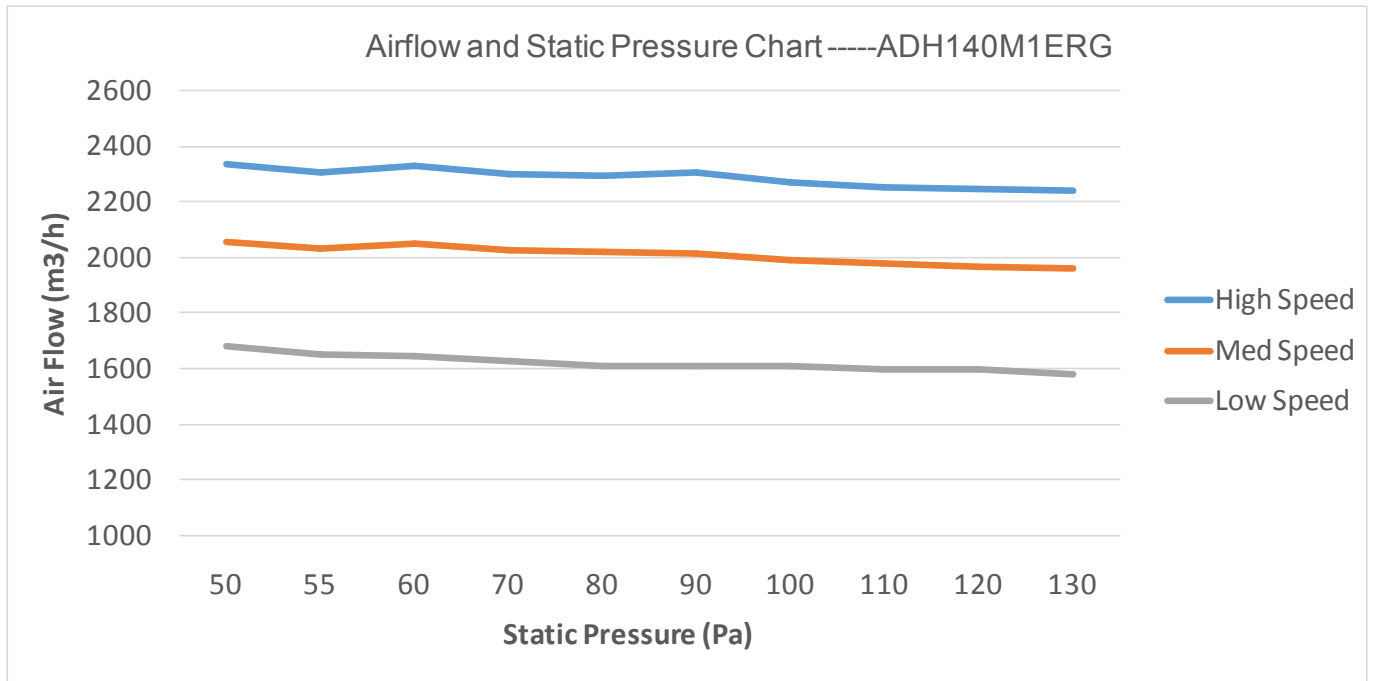

## 6. Instalation

### 6.1 Safety precautions

The machine is adaptive in following situation

1. Applicable ambient temperature range:

Cooling	Indoor temperature	max. DB/WB min. DB/WB	32/23°C
	Outdoor temperature		18/14°C
Heating	Indoor temperature		46/26°C
	Outdoor temperature		10/16°C
Heating	Indoor temperature	27°C	
	Outdoor temperature	15°C	
			24/18°C
			-15°C

- If the supply cord is damaged, it must be replaced by the manufacturer or its service agent or a similar qualified person.
- If the fuse on the indoor Pc board is broken please change it with the type of T 3.15A /250V( For ADH105M1ERG, ADH125M1ERG, ADH140M1ERG)• or the type T5A /250V (For ADH071M1ERG, ADH090M1ERG).
- The wiring method should be in line with the local wiring standard.
- The power cable and connect cable should be self provided.
- The breaker of the air conditioner should be all pole switch, and the distance between its two contacts should be no less than 3mm.
- The indoor unit installation height is at least 2.5m.
- A leakage breaker must be installed.
- For ADH071M1ERG, ADH090M1ERG, we can get the 4 different ESP through adjust the indoor unit PCB SW1-4 and SW1-5, please refer below:

SW1								Static pressure
(1)	(2)	(3)	(4)	(5)	(6)	(7)	(8)	
-	-	-	OFF	OFF	-	-	-	10 Pa(default)
-	-	-	OFF	OFF	-	-	-	30 Pa
-	-	-	ON	ON	-	-	-	50 Pa
-	-	-	ON	ON	-	-	-	70 Pa

Attention:

cut off the power supply to adjust the SW1-4, and SW1-5, or else the operation is invalid. When the wired controller settings, wired controller to prevail.

For ADH105M1ERG, ADH125M1ERG, ADH140M1ERG, static pressure selection need achieved by wired controller, refer wired controller's manual to get details

## 6.2 Parts and Functions

ADH071M1ERG

ADH090M1ERG

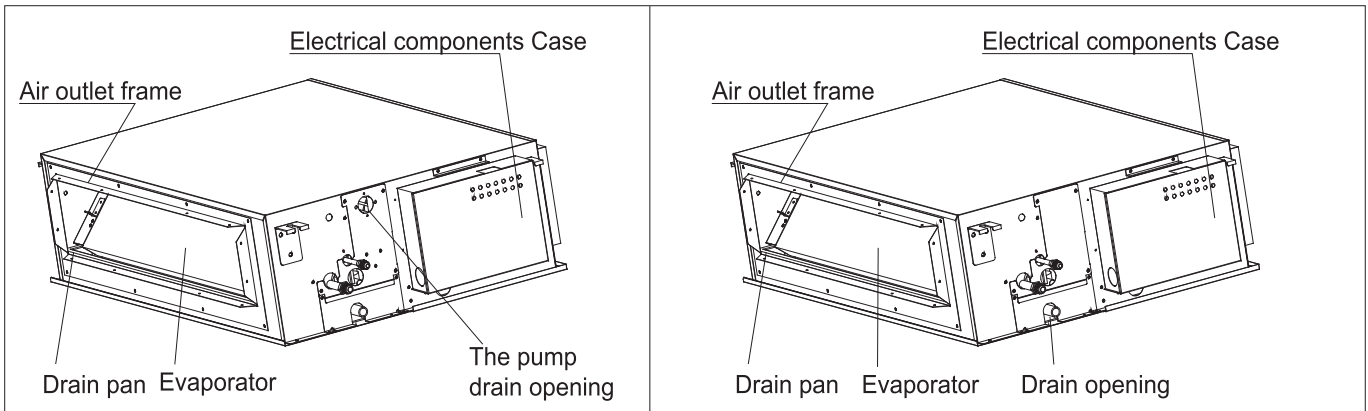

ADH105M1ERG ADH125M1ERG ADH140M1ERG

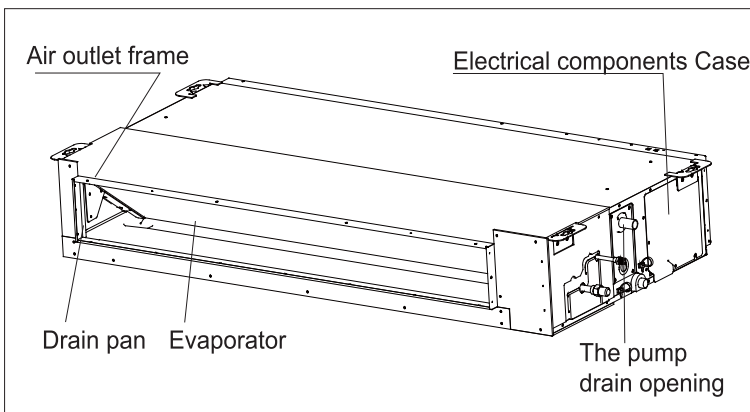

## 6.3 Installation procedure

### Note

All wiring of this installation must comply with NATIONAL, STATE AND LOCAL REGULATIONS. These instructions do not cover all variations for every kind of installation circumstance. Should further information be desired or should particular problems occur, the matter should be referred to your local distributor.

### WARNING

BE SURE TO READ THESE INSTRUCTIONS CAREFULLY BEFORE BEGINNING INSTALLATION. FAILURE TO FOLLOW THESE INSTRUCTIONS COULD CAUSE SERIOUS INJURY OR DEATH, EQUIPMENT MALFUNCTION AND/OR PROPERTY DAMAGE.

#### Preparation of indoor unit

Before or during the installation of the unit, assemble necessary optional panel etc. depending on the specific type.

**Select places for installation satisfying following conditions and at the same time obtain the consent on the part of your client user.**

1. Places where chilled or heated air circulates freely. When the installation height exceeds 3m warmed air stays close to the ceiling. In such cases, suggest your client users to install air circulators.
2. Places where perfect drainage can be prepared and sufficient drainage.
3. Places free from air disturbances to the suction port and blowout hole of the indoor unit, places where the fire alarm may not malfunction or short circuit.
4. Places with the environmental dew point temperature is lower than 28°C and the relative humidity is less than 80%. (When installing at a place under a high humidity environment, pay sufficient attention to the prevention of dewing such as thermal insulation of the unit. )
5. Ceiling height shall have the following height.

	ADH071M1ERG ADH090M1ERG ADH105M1ERG ADH125M1ERG ADH140M1ERG
Combination with silent panel	366mm

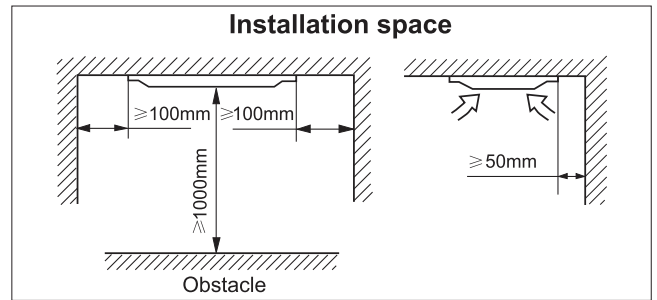

**Avoid installation and use at those places listed below.**

1. Places exposed to oil splashes or steam (e.g. kitchens and machine plants).  
Installation and use at such places incur deteriorations in the performance or corrosion with the heat exchanger or damage in molded synthetic resin parts.
2. Places where corrosive gas (such as sulfurous acid gas) or inflammable gas (thinner, gasoline etc.) in generated or remains. Installation and use at such places cause corrosion in the heat exchanger and damage in molded synthetic resin parts.
3. Places adjacent to equipment generating electromagnetic waves or high frequency waves such as in hospitals.  
Generated noise may cause malfunctioning of the controller.

**Pipe size**

Model	Liquid side	Gas side
ADH071M1ERG	$\varnothing 9.52\text{mm}$	$\varnothing 15.88\text{mm}$
ADH090M1ERG		
ADH105M1ERG		
ADH125M1ERG		
ADH140M1ERG		

**Preparation for suspending the unit**

1. Size of hole at ceiling and position of hanging bolts

<combination with silent panel>

ADH071M1ERG ADH090M1ERG

ADH105M1ERG ADH125M1ERG ADH140M1ERG

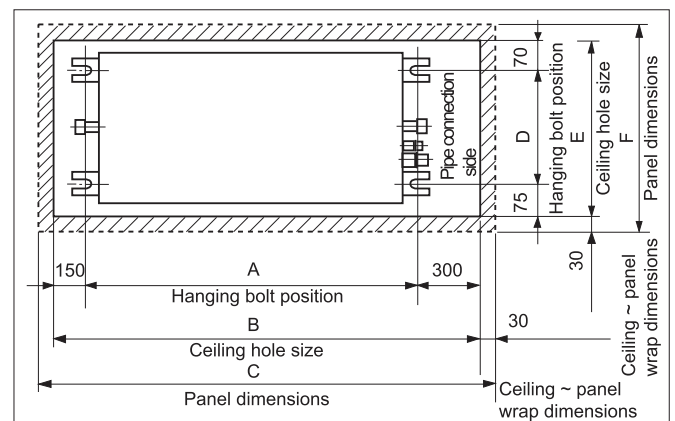
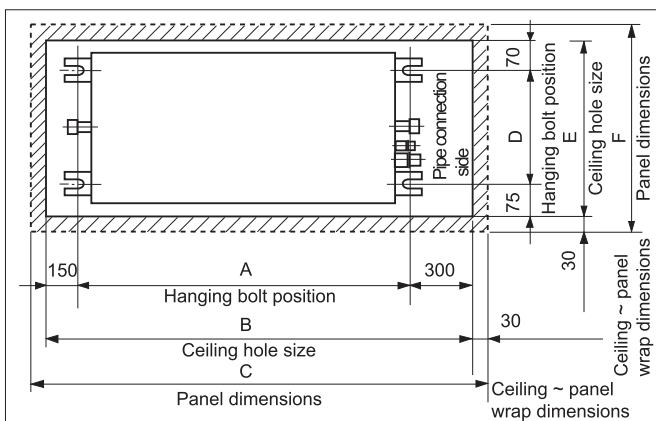

Model	Dimensions	A (mm)	B (mm)	C (mm)	D (mm)	E (mm)	F (mm)
ADH071M1ERG ADH090M1ERG		983	1433	1493	595	740	800
ADH105M1ERG ADH125M1ERG ADH140M1ERG		1172	1622	1682	480	625	685

2. Hanger bolts installation

Use care of the piping direction when the unit is installed.

**Installation of indoor unit**

Fix the indoor unit to the hanger bolts.

If required, it is possible to suspend the unit to the beam, etc. Directly by use of the bolts without using the hanger bolts.

**Note**

When the dimensions of main unit and ceiling holes does not match, it can be adjusted with the slot holes of hanging bracket.

**Adjusting to the levelness**

1. Adjust the out of levelness using a level or by the following method. Make adjustment so that the relation between the lower surface of the unit proper and water level in the hose becomes as given below.
2. Unless the adjustment to the levelness is made properly, malfunctioning or failure of the float switch may occur.

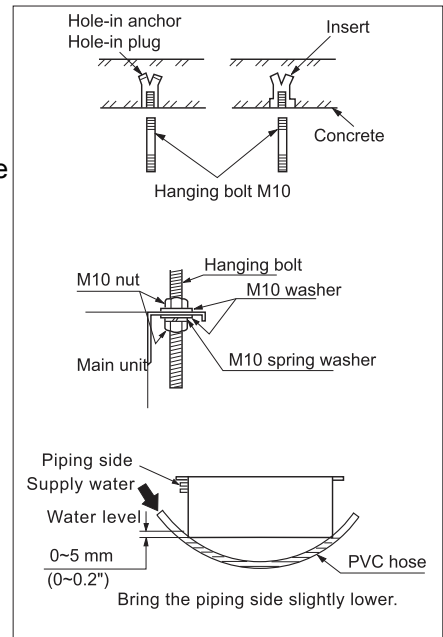

**Drain piping**

1. Drain piping should always be in a downhill grade (1/50~1/100) and avoid riding across an elevation or making traps.

**Good piping**

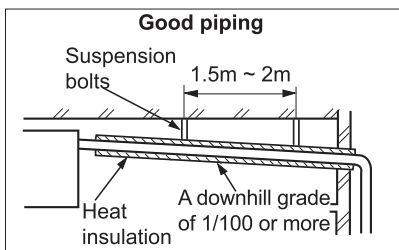

**Improper piping**

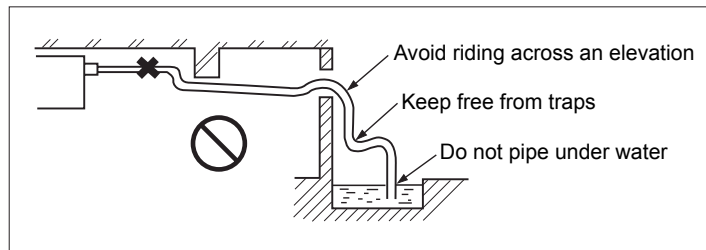

**For unit without water pump**

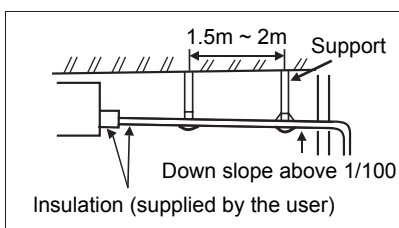

Unit model	The size of drain opening
ADH071M1ERG	ø 21mm
ADH090M1ERG	
ADH105M1ERG	
ADH125M1ERG	
ADH140M1ERG	

2. When connecting the drain pipe to unit, pay sufficient attention not to apply excess force to the piping on the unit side. Also, fix the piping at a point as close as possible to the unit.

- For unit without water pump, please refer to the diagram and select drain pipe size according to drain opening inner diameter size. The drain pipe shall slant downwards (greater than 1/100). The horizontal length of the drain pipe shall be less than 20 m. In case of long pipe, supports shall be provided every 1.5 ~ 2m to prevent wavy form. Central piping shall be laid out according to the right figure. Take care not to apply external force onto the drain pipe connection part.
- For unit with water pump drain pipe use hard PVC general purpose pipe VP which can be purchased locally. When connecting, insert a PVC pipe end securely into the drain socket before tightening securely using the attached drain hose and clamp. Adhesive must not be used for connection of the drain socket and drain hose (accessory).
- When constructing drain piping for several units, position the common pipe about 100 mm below the drain outlet of each unit as shown in the sketch. Use VP 30(1 1/4") or thicker pipe for this purpose.
- The hard PVC pipe put indoor side should be heat insulated.
- The height of the drain head can be elevated up to a point 500 mm above the ceiling, and when an obstacle exists in the ceiling space, elevate the piping to avoid the obstacle using an elbow or corresponding gadget. When doing this, if the stretch for the needed height is higher than 500 mm, the back flow quantity of drain at the event of interruption of the operation gets too much and it may cause overflow at the drain pan. Therefore, make the height of the drain pipe within the distance given in the sketch below.

### Drainage Test

- Conduct a drainage test after completion of the electrical work.
- During the trial, make sure that drain flows properly through the piping and that no water leaks from connections.
- In case of a new building, conduct the test before it is furnished with the ceiling.
- Be sure to conduct this test even when the unit is installed in the heating season.

### Procedures

- Supply about 1000 cc of water to the unit through the air outlet using a feed water pump.
- check the drain while cooling operation.

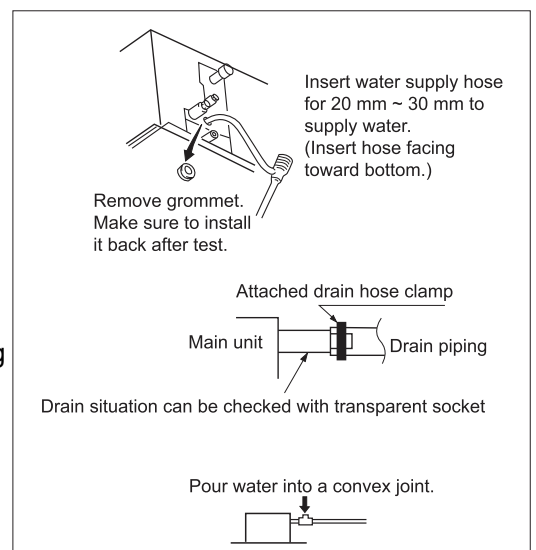
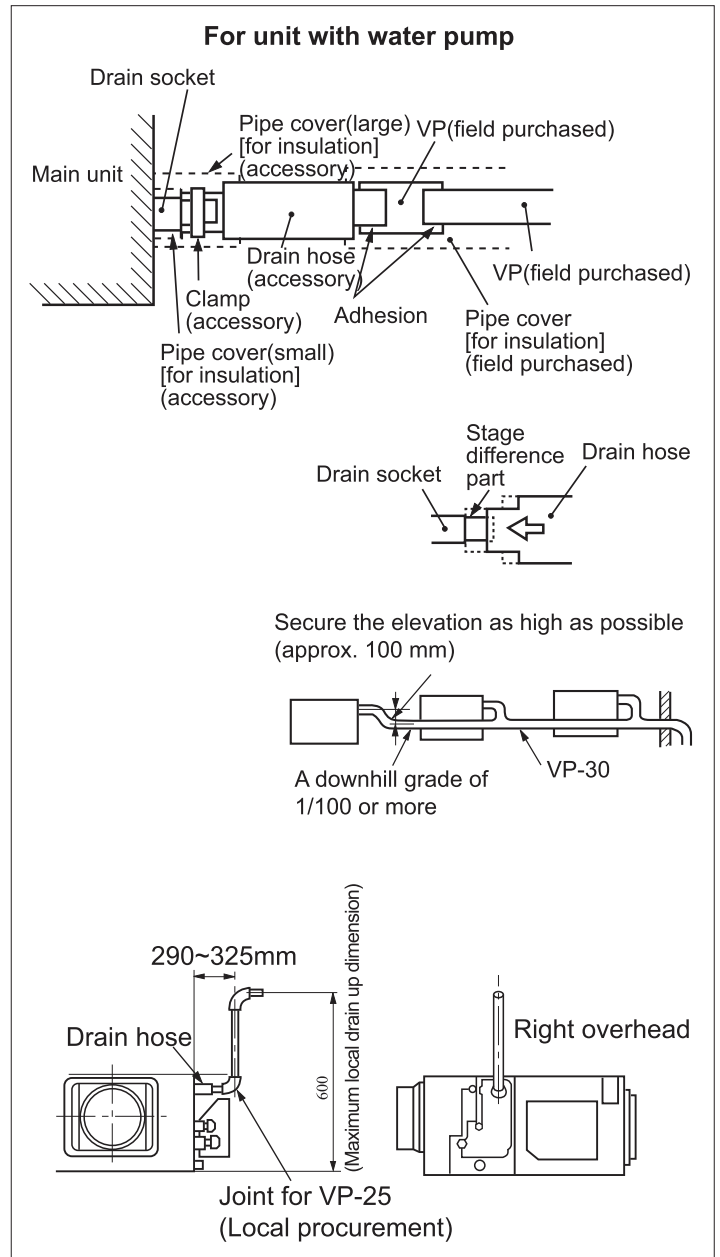



Before the electrical work has not been completed, connect a convex joint in the drain pipe connection to provide a water inlet. Then, check if water leaks from the piping system and that drain flows through the drain pipe normally.

**Installation work for air outlet ducts**

calculate the draft and external static pressure and select the length, shape and blowout.

**(A) Blowout duct**

- 2-spot, 3-spot and 4-spot with  $\Phi$  200 type duct are the standard specifications.

**Note:**

- 1 Shield the central blowout hole for 2 spot.
- 2 Shield the blowout hole around the center for 3 spot.

- Limit the difference in length between spots at less than 2:1.
- Reduce the length of duct as much as possible.
- Reduce the number of bends as much as possible. (corner R should be as larger as possible.)
- Use a band, etc. to connect the main unit and the blowout duct flange.
- Conduct the duct installation work before finishing the ceiling.

**Connection of suction, exhaust ducts**

**1. Fresh air inlet**

- Inlet can be selected from the side or rear faces depending on the working conditions.
- Use the rear fresh air inlet when the simultaneous intake and exhaust is conducted. (Side inlet cannot be used.)

**2. Exhaust (Make sure to use also the suction.) Use the side exhaust port.**

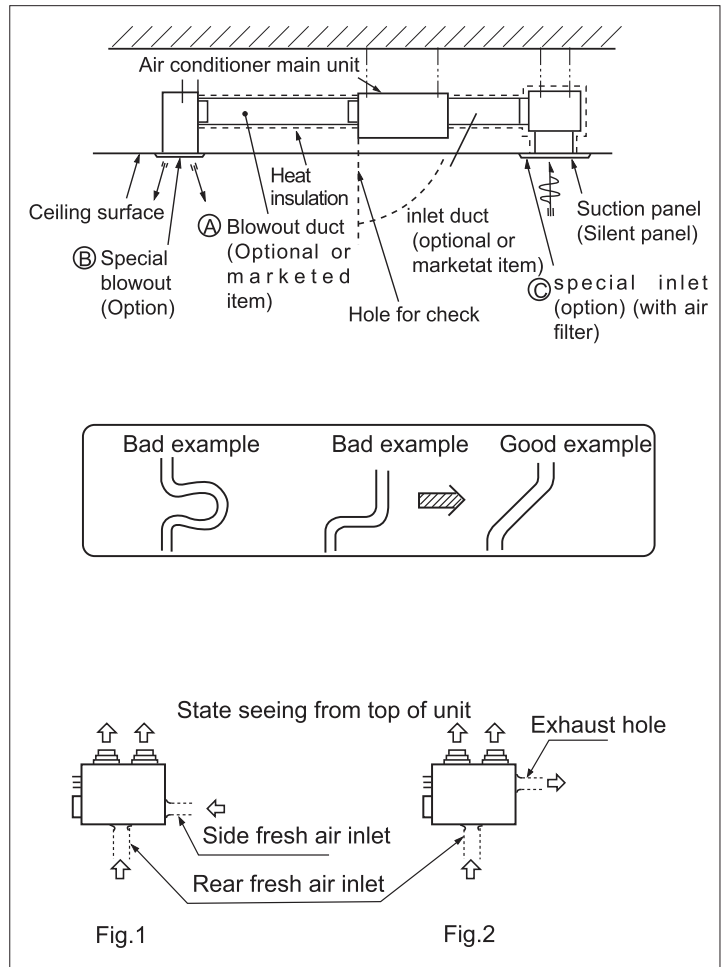

**⚠ WARNING**

**DANGER OF BODILY INJURY OR DEATH**

- TURN OFF ELECTRICAL POWER AT CIRCUIT BREAKER OR POWER SOURCE BEFORE MAKING ANY ELECTRICAL CONNECTIONS.
- GROUND CONNECTIONS MUST BE COMPLETED BEFORE MAKING LINE VOLTAGE CONNECTIONS.

**Precautions for electrical wiring**

- Electrical wiring work should be conducted only by authorized personnel.
- Do not connect more than three wires to the terminal block. Always use round type crimped terminal lugs with insulated grip on the ends of the wires.
- Use copper conductor only.

**Selection of size of power supply and interconnecting wires**

Select wire sizes and circuit protection from table below. (This table shows 20 m length wires with less than 2% voltage drop.)

Item Model	Phase	Circuit breaker		Power source wire size (minimum) (mm <sup>2</sup> )	Earth leakage breaker	
		Switch breaker (A)	Overcurrent protector rated capacity (A)		Switch breaker(A)	Leak current(mA)
ADH071M1ERG ADH090M1ERG	1	30	26	4.0	40	30
ADH105M1ERG ADH125M1ERG ADH140M1ERG	1	40	30	6.0	40	30

### Wiring connection

Make wiring to supply power to the outdoor unit, so that the power for the indoor unit is supplied by terminals.

#### Outdoor 3 phase type

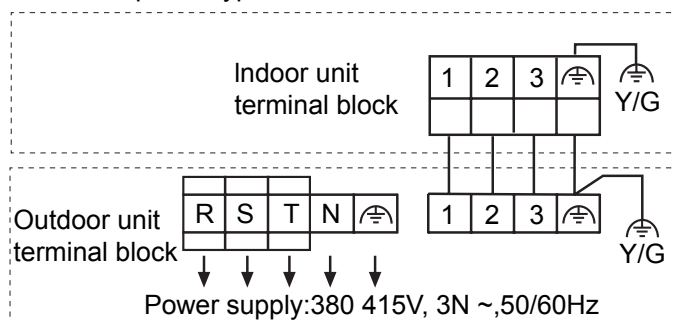

#### Outdoor single phase type

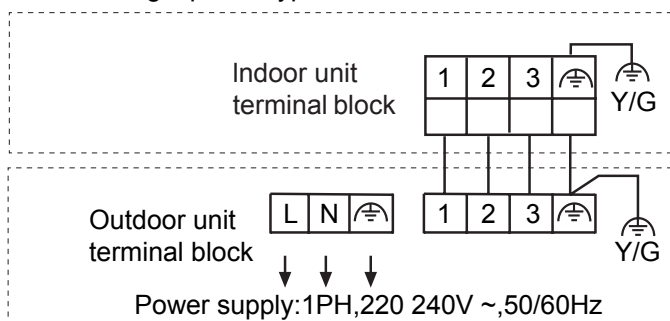

7. Sound pressure level---ADH090M1ERG

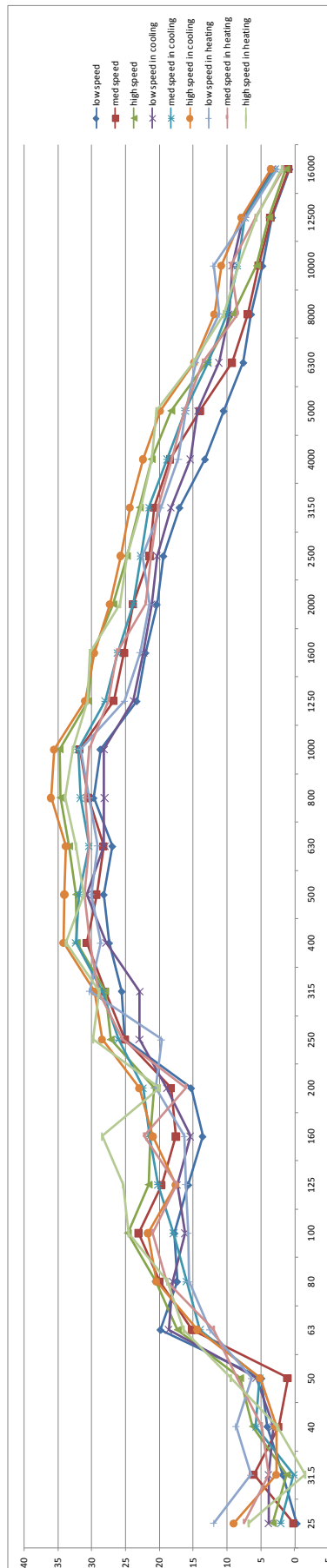

**Part 4 Outdoor Units**

1. Specification .....	55
2. Dimension .....	61
3. Piping diagram .....	63
4. Wiring diagram .....	64
5. Noise level.....	67
6. Outdoor performace curves.....	73
7. Installation .....	79

## 1. Specification

Item		Model	1UH071N1ERG		
Power cable			H05RN-F 3G 4.0mm <sup>2</sup>		
Communication cable/Connecting cable			H05RN-F 4G 2.5mm <sup>2</sup>		
Power source		N, V, Hz	1PH, 220-240V~, 50/60Hz		
Start current		A	3		
Outdoor unit	Unit model (color)		1UH071N1ERG (WHITE)		
	Compressor	Model/Manufacture/ place	TNB220FFEMC		
		Oil model	FV50S		
		Oil charging	CC	520	
		Type	Rotary		
	Fan	Type×Number	Axial×1		
		Speed	r/min	650/600/500/400/300/200	
		Fan motor output/input power	kW	100/120	
		Air-flow (H-M-L)	m <sup>3</sup> /h	3200	
	Heat exchanger	Type/Diameter	mm	TP2M/Φ7 wide fin	
		Row/Fin pitch		2	1.65
		Total area	m <sup>2</sup>	/	
	Dimension	External (L×M×H)	mm×mm×mm	965*950*370	
		Package (L×M×H)	mm×mm×mm	1095*1050*450	
	Drainage pipe (material, I.D./O.D.)		mm	None	
	Refrigerant control method		mm/mm	2.2mm electronic expansion valve	
	Defrosting			Auto	
	Volume of accumulator		L	2.1	
	Sound power noise level (H-M-L)		dB (A)	64	
	Sound pressure noise level (H-M-L)		dB (A)	47	
Type of four way valve			SHF-4-10A		
Material of reduce noise			Felt		
Crankcase heater power		W	/		
Weight (Net/Shipping)		kg/kg	80/92		
Piping	Refrigerant	Type/Charge	g	R410A/2500	
		Recharge quantity	g/m	45	
	Pipe	Liquid	mm	9.52	
		Gas	mm	15.88	
	Connecting method			Flared	
	Between I.D & O.D	MAX. Drop	m	30	
MAX. Piping length		m	50		
Maximum pipe length without recharge refrigerant		m	20		
Working temp.	Cooling (Min-Max)		°C	-15~50	
	Heating (Min-Max)		°C	-20~24	
Norminal condition: Indoor temperature (cooling) : 27DB (°C)/19WB (°C) , Indoor temperature (heating) : 20DB (°C) Outdoor temperature (cooling) : 35DB (°C)/24WB (°C) , Outdoor temperature (heating) : 7DB (°C)/6WB (°C) The noise level will be measured in the third octave band limited values, using a Real Time Analyser calibrated sound intensity meter. It is a sound pressure noise level.					

Item		Model	1UH090N1ERG		
Power cable			H05RN-F 3G 4.0mm <sup>2</sup>		
Communication cable/Connecting cable			H05RN-F 4G 2.5mm <sup>2</sup>		
Power source		N, V, Hz	1PH, 220-240V~, 50/60Hz		
Start current		A	3		
Outdoor unit	Unit model (color)		1UH090N1ERG (WHITE)		
	Compressor	Model/Manufacture/ place	TNB220FFEMC		
		Oil model	FV50S		
		Oil charging	CC	520	
		Type	Rotary		
	Fan	Type×Number	Axial×1		
		Speed	r/min	700/650/600/500/400/300/200	
		Fan motor output/input power	kW	100/120	
		Air-flow (H-M-L)	m <sup>3</sup> /h	3500	
	Heat exchanger	Type/Diameter	mm	TP2M/Φ7 wide fin	
		Row/Fin pitch		2	1.65
		Total area	m <sup>2</sup>	/	
	Dimension	External (L×M×H)	mm×mm×mm	965*950*370	
		Package (L×M×H)	mm×mm×mm	1095*1050*450	
	Drainage pipe (material, I.D./O.D.)		mm	None	
	Refrigerant control method		mm/mm	2.2mm electronic expansion valve	
	Defrosting			Auto	
	Volume of accumulator		L	2.1	
	Sound power noise level (H-M-L)		dB (A)	66	
	Sound pressure noise level (H-M-L)		dB (A)	50	
Type of four way valve			SHF-4-10A		
Material of reduce noise			Felt		
Crankcase heater power		W	/		
Weight (Net/Shipping)		kg/kg	80/92		
Piping	Refrigerant	Type/Charge	g	R410A/2500	
		Recharge quantity	g/m	45	
	Pipe	Liquid	mm	9.52	
		Gas	mm	15.88	
	Connecting method			Flared	
	Between I.D & O.D	MAX. Drop	m	30	
MAX. Piping length		m	50		
Maximum pipe length without recharge refrigerant		m	20		
Working temp.	Cooling (Min-Max)	°C	-15~50		
	Heating (Min-Max)	°C	-20~24		
Norminal condition: Indoor temperature (cooling) : 27DB (°C)/19WB (°C) , Indoor temperature (heating) : 20DB (°C) Outdoor temperature (cooling) : 35DB (°C)/24WB (°C) , Outdoor temperature (heating) : 7DB (°C)/6WB (°C) The noise level will be measured in the third octave band limited values, using a Real Time Analyser calibrated sound intensity meter. It is a sound pressure noise level.					

Item		Model	1UH105N1ERG		
Power cable			H05RN-F 3G 4.0mm <sup>2</sup>		
Communication cable/Connecting cable			H05RN-F 4G 2.5mm <sup>2</sup>		
Power source		N, V, Hz	1PH, 220-240V~, 50/60Hz		
Start current		A	3		
Outdoor unit	Unit model (color)		1UH105N1ERG (WHITE)		
	Compressor	Model/Manufacture/ place	TNB306FPPMC		
		Oil model	FV50S		
		Oil charging	CC	870	
		Type	Rotary		
	Fan	Type×Number	Axial×1		
		Speed	r/min	750/700/650/600/500/400/300	
		Fan motor output/input power	kW	100/120	
		Air-flow (H-M-L)	m <sup>3</sup> /h	4000	
	Heat exchanger	Type/Diameter	mm	TP2M/Φ7 wide fin	
		Row/Fin pitch		2	1.65
		Total area	m <sup>2</sup>	/	
	Dimension	External (L×M×H)	mm×mm×mm	965*950*370	
		Package (L×M×H)	mm×mm×mm	1095*1050*450	
	Drainage pipe (material, I.D./O.D.)		mm	None	
	Refrigerant control method		mm/mm	2.2mm electronic expansion valve	
	Defrosting		Auto		
	Volume of accumulator		L	2.1	
	Sound power noise level (H-M-L)		dB (A)	68	
	Sound pressure noise level (H-M-L)		dB (A)	52	
Type of four way valve		SHF-4-10A			
Material of reduce noise		Felt			
Crankcase heater power		W	/		
Weight (Net/Shipping)		kg/kg	82/94		
Piping	Refrigerant	Type/Charge	g	R410A/2500	
		Recharge quantity	g/m	45	
	Pipe	Liquid	mm	9.52	
		Gas	mm	15.88	
	Connecting method		Flared		
	Between I.D & O.D	MAX. Drop	m	30	
MAX. Piping length		m	50		
Maximum pipe length without recharge refrigerant		m	20		
Working temp.	Cooling (Min-Max)	°C	-15~50		
	Heating (Min-Max)	°C	-20~24		
Norminal condition: Indoor temperature (cooling) : 27DB (°C)/19WB (°C) , Indoor temperature (heating) : 20DB (°C) Outdoor temperature (cooling) : 35DB (°C)/24WB (°C) , Outdoor temperature (heating) : 7DB (°C)/6WB (°C) The noise level will be measured in the third octave band limited values, using a Real Time Analyser calibrated sound intensity meter. It is a sound pressure noise level.					

Item		Model	1UH125P1ERG			
Power cable			H05RN-F 3G 4.0mm <sup>2</sup>			
Communication cable			/			
Connecting cable			H05RN-F 4G 2.5mm <sup>2</sup>			
Power source		N, V, Hz	1PH~, 220~240, 50/60Hz			
Start current		A	3			
Outdoor unit	Unit model (color)		1UH125P1ERG (WHITE)			
	Compressor	Model/Manufacture/place		MNB42FFAMC-L (MITSUBISHI ELECTRIC COMPRESSOR CO., LTD)		
		Oil model		PVE (FV50S)		
		Oil charging		CC	1600	
		Type		Twin Rotary	1	
	Fan	Type×Number		Axial×2		
		Speed		r/min	650±40	
		Fan motor input power		kW	0.12×2	
		Fan motor output power		kW	0.10×2	
		Air-flow (H-M-L)		m <sup>3</sup> /h	6500	
	Heat exchanger	Type/Diameter		mm	TP2M/Φ7.0	
		Row/Fin pitch			2	1.4
		Total area		m <sup>2</sup>	1.17	
	Dimension	External	(W×D×H)	mm×mm×mm	950×370×1350	
		Package	(W×D×H)	mm×mm×mm	1090×480×1500	
	Drainage pipe (material, I.D./O.D.)		mm	None		
	Refrigerant control method		mm/mm	ELECTRONIC VAVE 3.0mm		
	Defrosting			Auto		
	Volume of accumulator		L	4.0		
	Sound power Noise level (H-M-L)		dB (A)	69		
Sound pressure Noise level (H-M-L)		dB (A)	52			
Type of four way valve			SHF-20D-46			
Material of reduce noise			XPE			
Crankcase heater power		W	38			
Weight (Net/Shipping)		kg/kg	105/118			
Piping	Refrigerant	Type/Charge		g	R410A/3700	
		Maximum pipe length without recharge refrigerant			30	
		Recharge quantity		g/m	45	
	Pipe	Liquid		mm	9.52	
		Gas		mm	15.88	
	Connecting method			Flared		
	Between I.D & O.D	MAX. Drop		m	30	
MAX. Piping length		m	75			
Norminal condition:						
Indoor temperature (cooling) : 27DB (°C)/19WB (°C) , Indoor temperature (heating) : 20DB (°C)						
Outdoor temperature (cooling) : 35DB (°C)/24WB (°C) , Outdoor temperature (heating) : 7DB (°C)/6WB (°C)						
The noise level will be measured in the third octave band limited values, using a Real Time Analyser calibrated sound intensity meter. It is a sound pressure noise level.						



Item		Model	1UH125P1ERK			
Power cable			H05RN-F 5G 2.5mm <sup>2</sup>			
Communication cable			/			
Connecting cable			H05RN-F 4G 2.5mm <sup>2</sup>			
Power source		N, V, Hz	3N~, 380~415, 50/60Hz			
Start current		A	3			
Outdoor unit	Unit model (color)		1UH125P1ERG (WHITE)			
	Compressor	Model/Manufacture/place		MNB42FFAMC-L (MITSUBISHI ELECTRIC COMPRESSOR CO., LTD)		
		Oil model		PVE (FV50S)		
		Oil charging		CC	1600	
		Type		Twin Rotary 1		
	Fan	Type×Number		Axial×2		
		Speed		r/min	650±40	
		Fan motor input power		kW	0.12×2	
		Fan motor output power		kW	0.10×2	
		Air-flow (H-M-L)		m <sup>3</sup> /h	6500	
	Heat exchanger	Type/Diameter		mm	TP2M/Φ7.0	
		Row/Fin pitch			2	1.4
		Total area		m <sup>2</sup>	1.17	
	Dimension	External	(W×D×H)	mm×mm×mm	950×370×1350	
		Package	(W×D×H)	mm×mm×mm	1090×480×1500	
	Drainage pipe (material, I.D./O.D.)		mm	None		
	Refrigerant control method		mm/mm	ELECTRONIC VAVE 3.0mm		
	Defrosting			Auto		
	Volume of accumulator		L	4.0		
	Sound power Noise level (H-M-L)		dB (A)	69		
Sound pressure Noise level (H-M-L)		dB (A)	52			
Type of four way valve			SHF-20D-46			
Material of reduce noise			XPE			
Crankcase heater power		W	38			
Weight (Net/Shipping)		kg/kg	108/121			
Piping	Refrigerant	Type/Charge		g	R410A/3700	
		Maximum pipe length without recharge refrigerant			30	
		Recharge quantity		g/m	45	
	Pipe	Liquid		mm	9.52	
		Gas		mm	15.88	
	Connecting method			Flared		
	Between I.D & O.D	MAX. Drop		m	30	
MAX. Piping length		m	75			
Norminal condition: Indoor temperature (cooling) : 27DB (°C)/19WB (°C) , Indoor temperature (heating) : 20DB (°C) Outdoor temperature (cooling) : 35DB (°C)/24WB (°C) , Outdoor temperature (heating) : 7DB (°C)/6WB (°C) The noise level will be measured in the third octave band limited values, using a Real Time Analyser calibrated sound intensity meter. It is a sound pressure noise level.						

Item		Model	1UH140P1ERK			
Power cable			H05RN-F 5G 2.5mm <sup>2</sup>			
Communication cable			/			
Connecting cable			H05RN-F 4G 2.5mm <sup>2</sup>			
Power source		N, V, Hz	3N~, 380~415, 50/60Hz			
Start current		A	3			
Outdoor unit	Unit model (color)		1UH125P1ERG (WHITE)			
	Compressor	Model/Manufacture/place		MNB42FFAMC-L (MITSUBISHI ELECTRIC COMPRESSOR CO., LTD)		
		Oil model		PVE (FV50S)		
		Oil charging		CC	1600	
		Type		Twin Rotary	1	
	Fan	Type×Number		Axial×2		
		Speed		r/min	700±40	
		Fan motor input power		kW	0.12×2	
		Fan motor output power		kW	0.10×2	
		Air-flow (H-M-L)		m <sup>3</sup> /h	7000	
	Heat exchanger	Type/Diameter		mm	TP2M/Φ7.0	
		Row/Fin pitch			2	1.4
		Total area		m <sup>2</sup>	1.17	
	Dimension	External (W×D×H)		mm×mm×mm	950×370×1350	
		Package (W×D×H)		mm×mm×mm	1090×480×1500	
	Drainage pipe (material, I.D./O.D.)		mm	None		
	Refrigerant control method		mm/mm	ELECTRONIC VAVE 3.0mm		
	Defrosting			Auto		
	Volume of accumulator		L	4.0		
	Sound power Noise level (H-M-L)		dB (A)	70		
Sound pressure Noise level (H-M-L)		dB (A)	53			
Type of four way valve			SHF-20D-46			
Material of reduce noise			XPE			
Crankcase heater power		W	38			
Weight (Net/Shipping)		kg/kg	108/121			
Piping	Refrigerant	Type/Charge		g	R410A/3700	
		Maximum pipe length without recharge refrigerant			30	
		Recharge quantity		g/m	45	
	Pipe	Liquid		mm	9.52	
		Gas		mm	15.88	
	Connecting method			Flared		
	Between I.D & O.D	MAX. Drop		m	30	
MAX. Piping length		m	75			
Norminal condition: Indoor temperature (cooling) : 27DB (°C)/19WB (°C) , Indoor temperature (heating) : 20DB (°C) Outdoor temperature (cooling) : 35DB (°C)/24WB (°C) , Outdoor temperature (heating) : 7DB (°C)/6WB (°C) The noise level will be measured in the third octave band limited values, using a Real Time Analyser calibrated sound intensity meter. It is a sound pressure noise level.						

2. Dimension

1UH71N1ERG 1UH90N1ERG 1UH105N1ERG

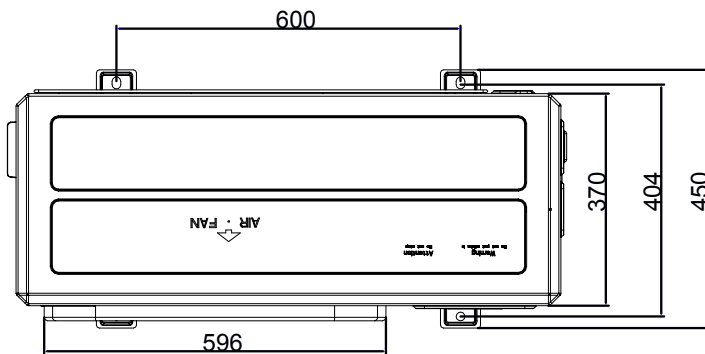
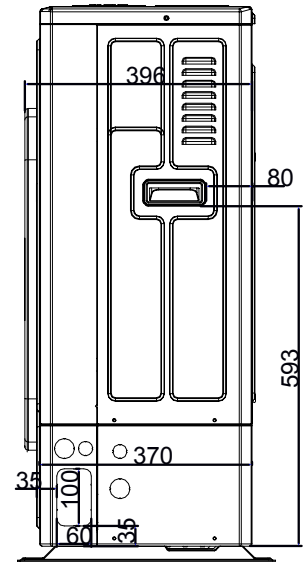
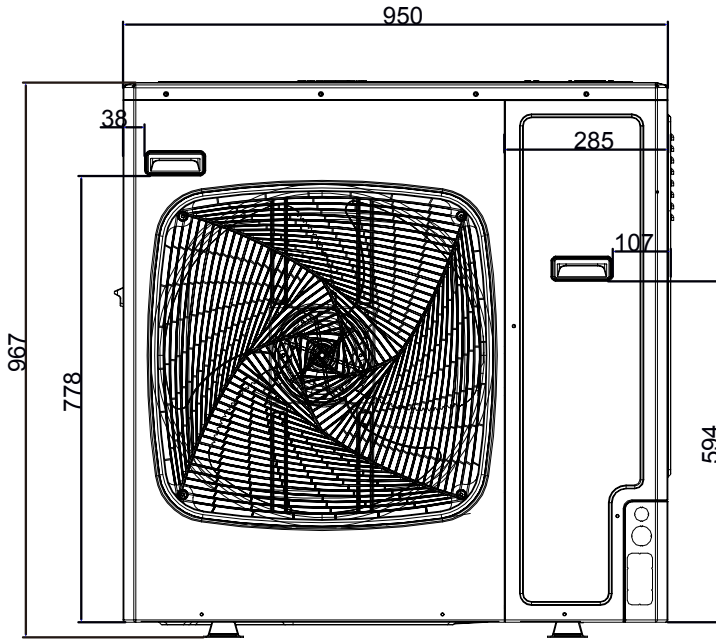

1UH125P1ERG 1UH125P1ERK 1UH140P1ERK

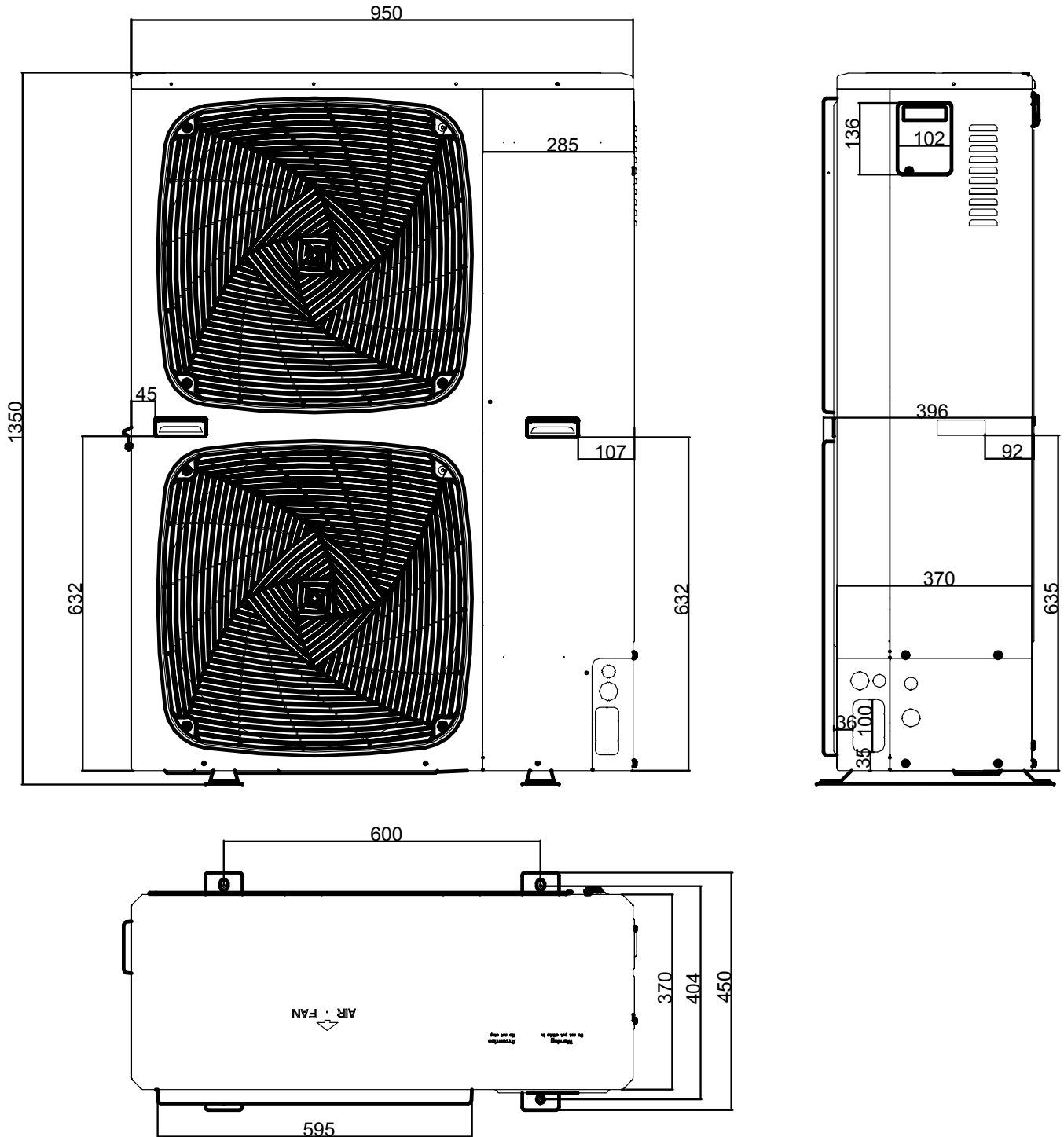

3. Piping diagram

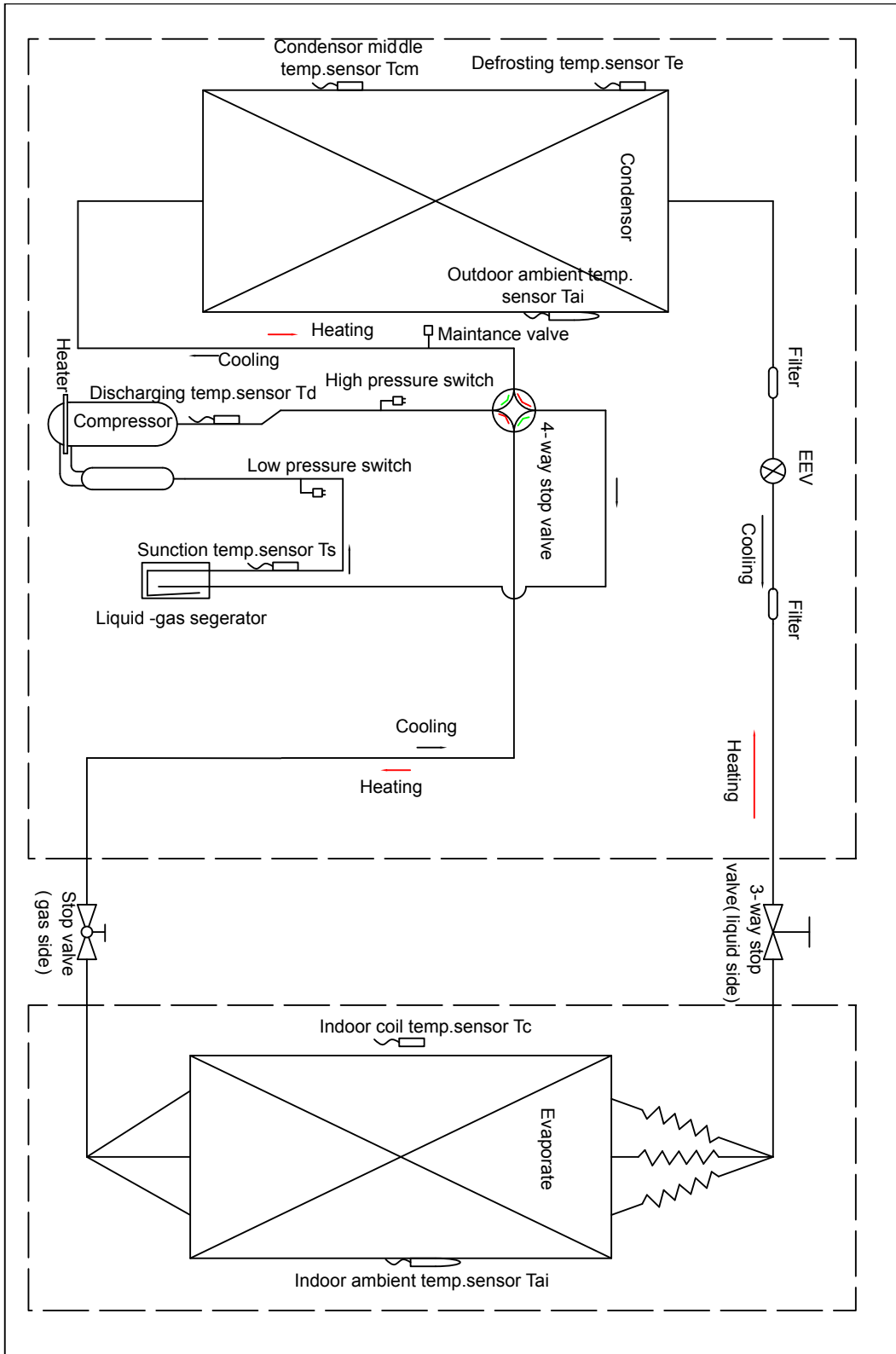

## 4. Wiring diagram

1UH071&090&105N1ERG

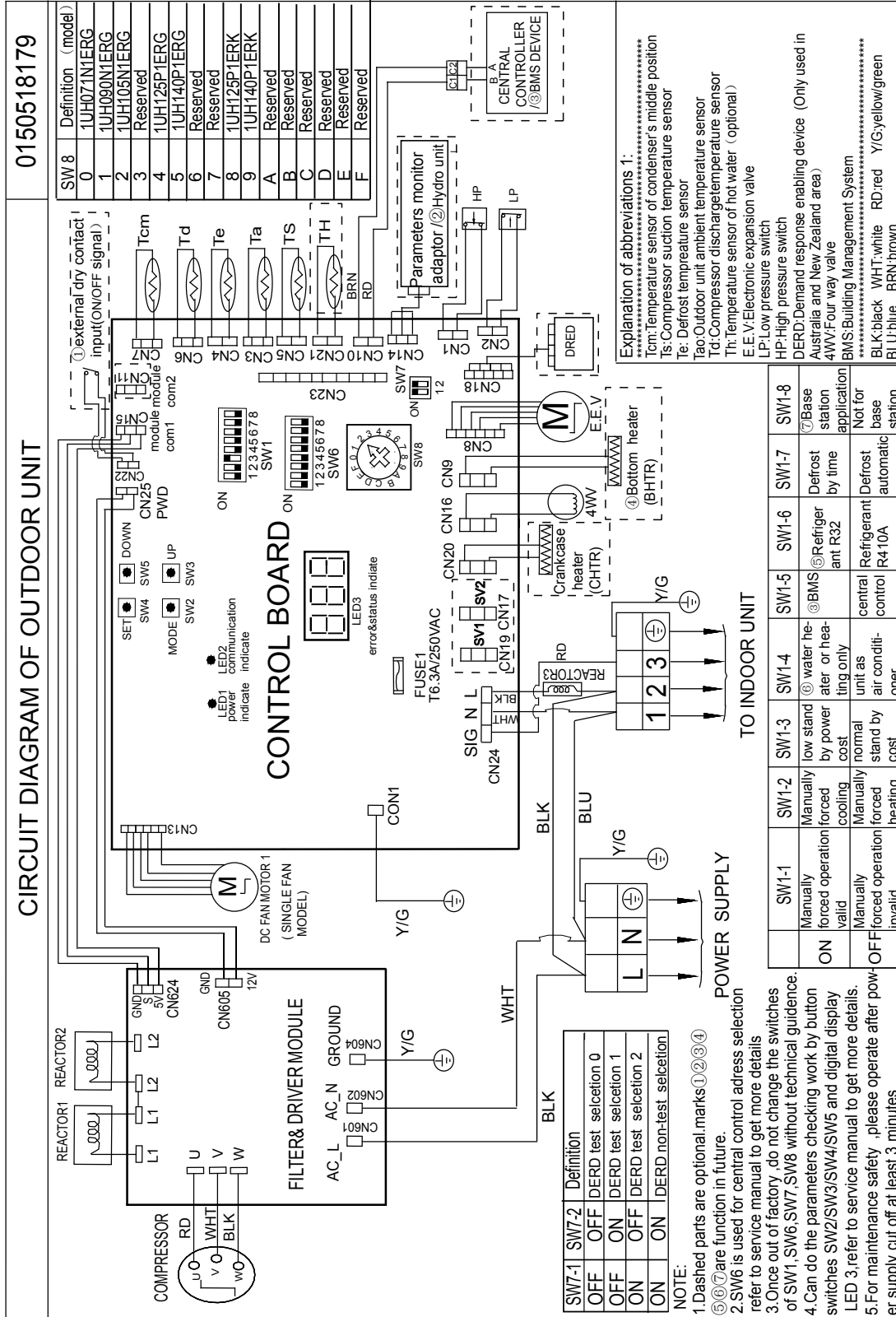

1UH125&140P1ERG

0150516939

CIRCUIT DIAGRAM OF OUTDOOR UNIT

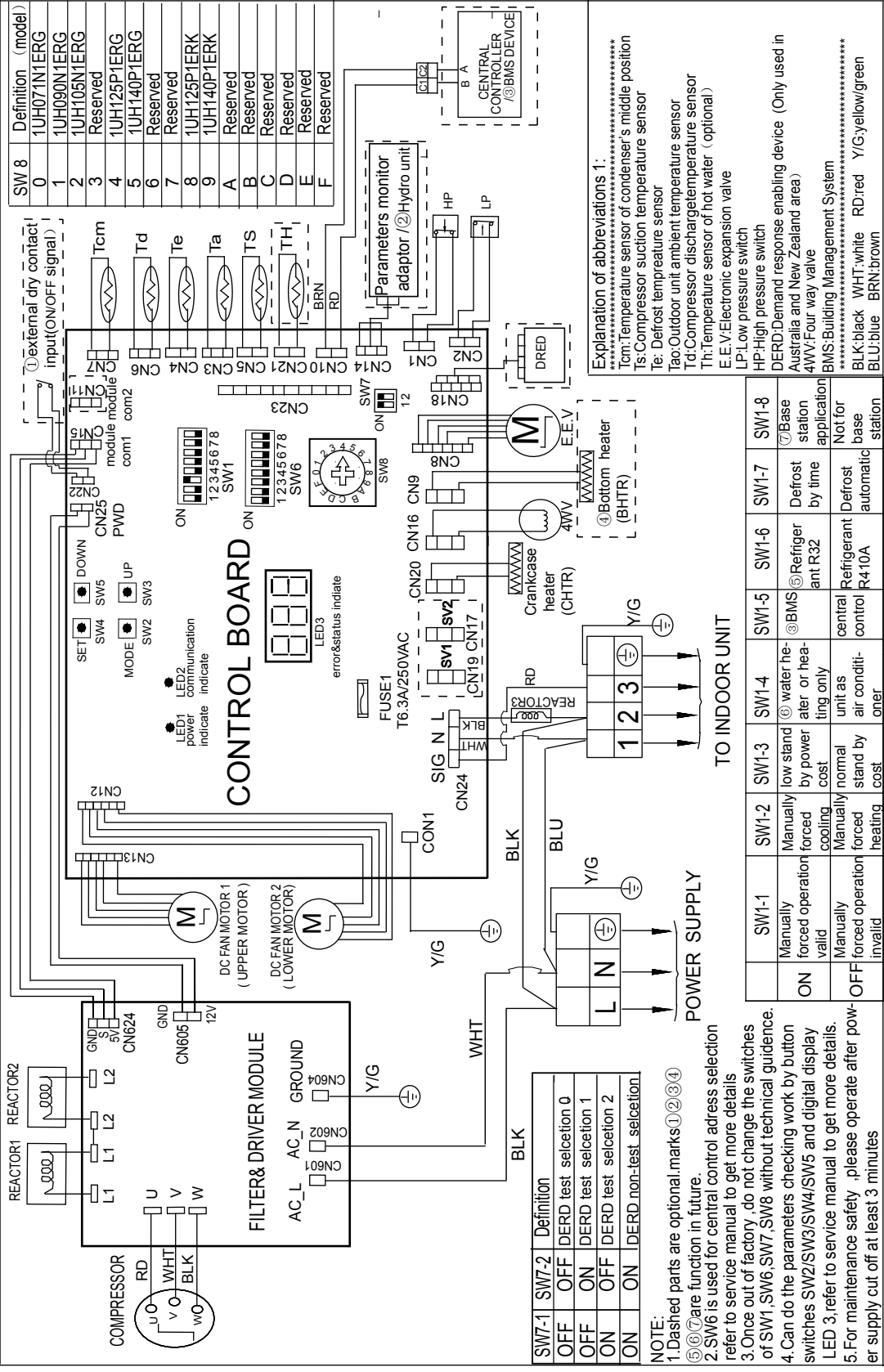

NOTE:  
 1. Dashed parts are optional, marks ①②③④  
 ⑤⑥⑦ are function in future.  
 2. SW6 is used for central control address selection refer to service manual to get more details  
 3. Once out of factory, do not change the switches of SW1, SW6, SW7, SW8 without technical guidance.  
 4. Can do the parameters checking work by button switches SW2/SW3/SW4/SW5 and digital display LED 3, refer to service manual to get more details.  
 5. For maintenance safety, please operate after power supply cut off at least 3 minutes

1UH125&140P1ERK

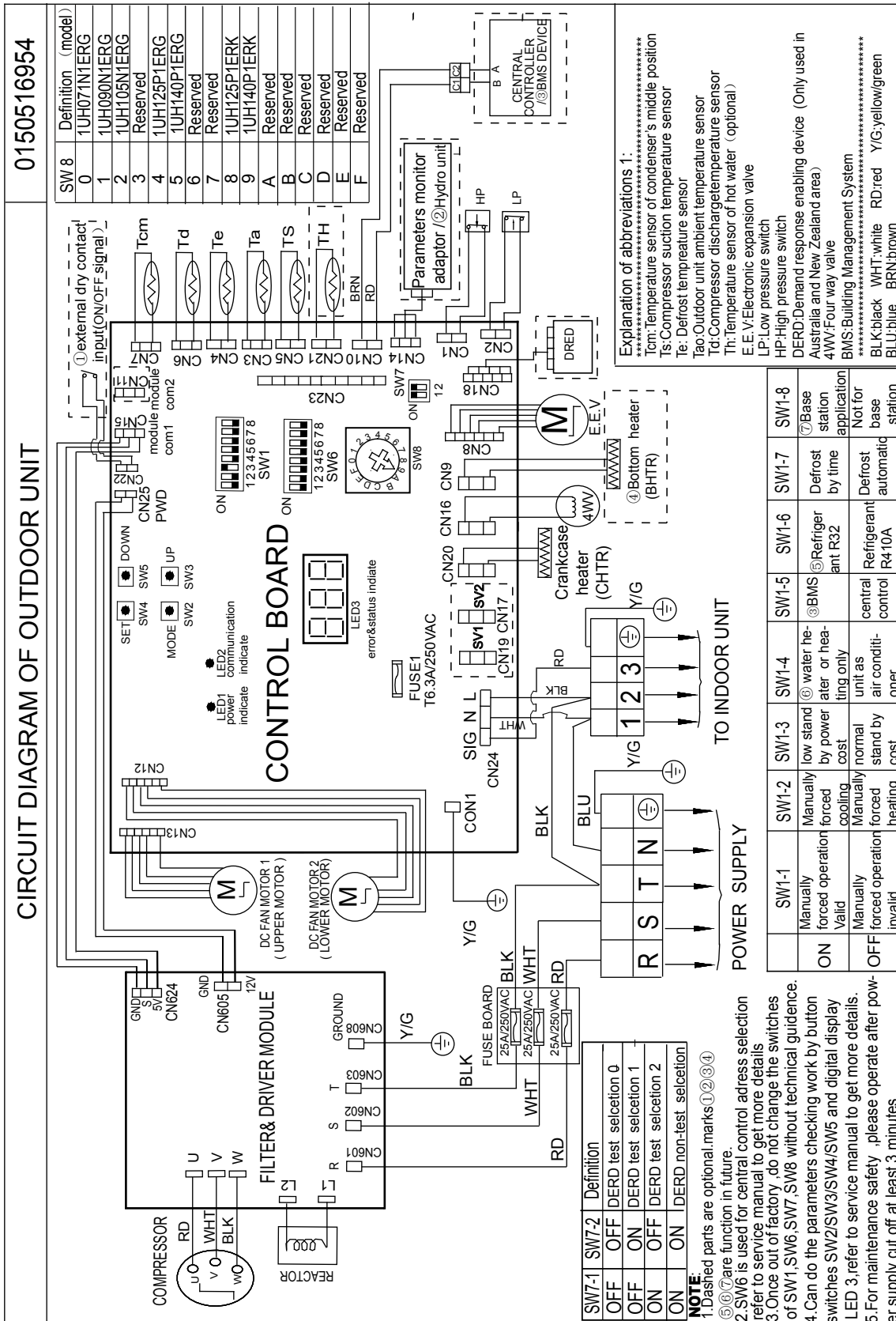



5. Noise level

5.1 1UH071N1ERG

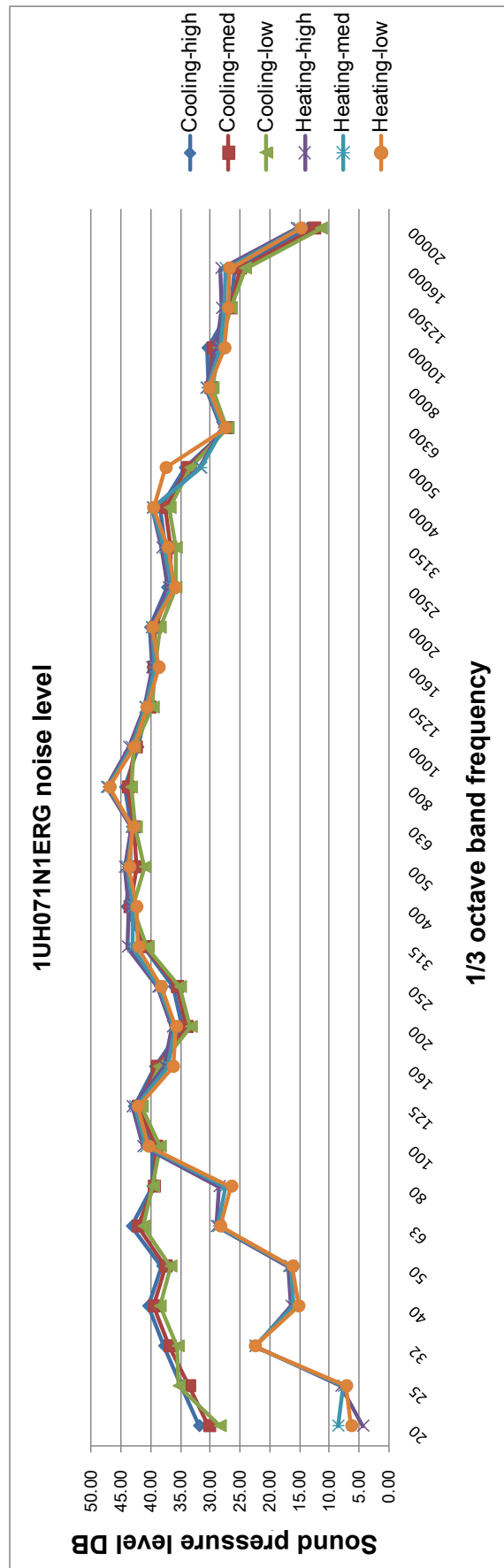

## 5.2 1UH090N1ERG

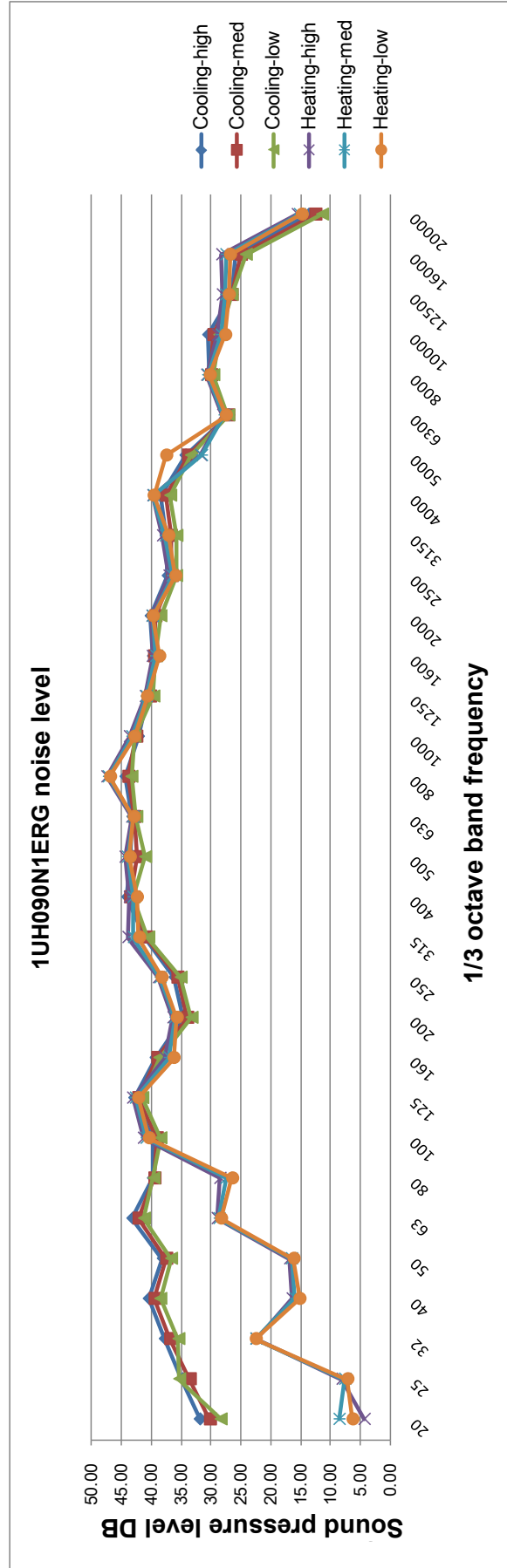

5.3 1UH105N1ERG

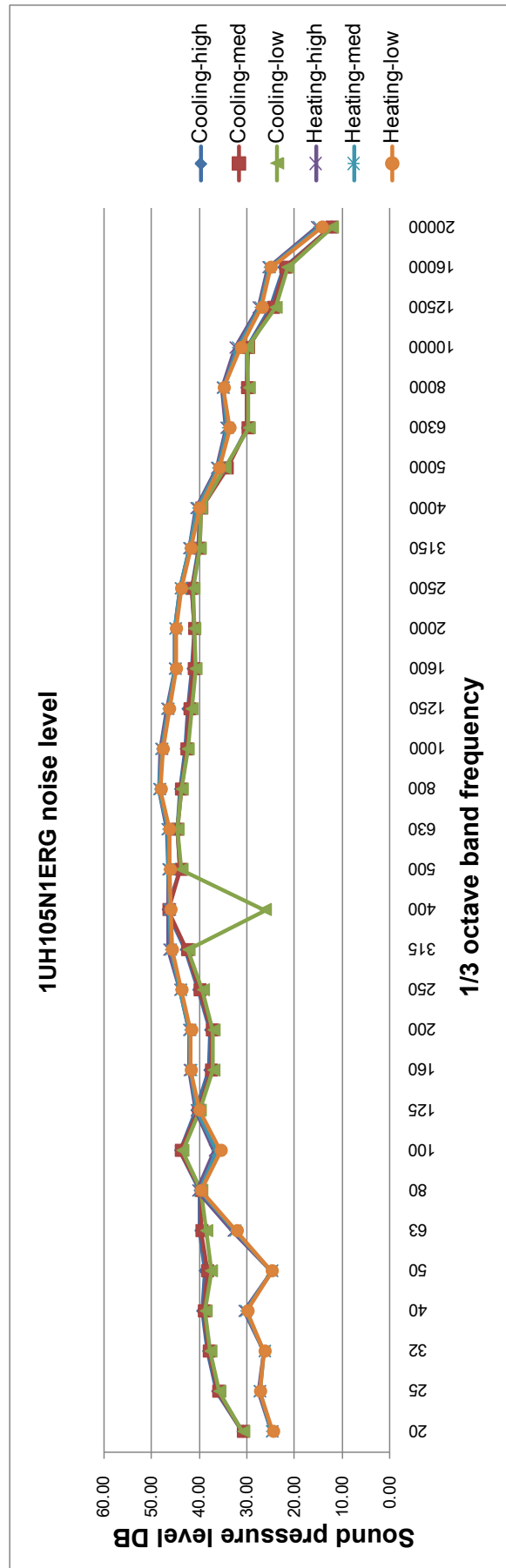

## 5.4 1UH125P1ERG

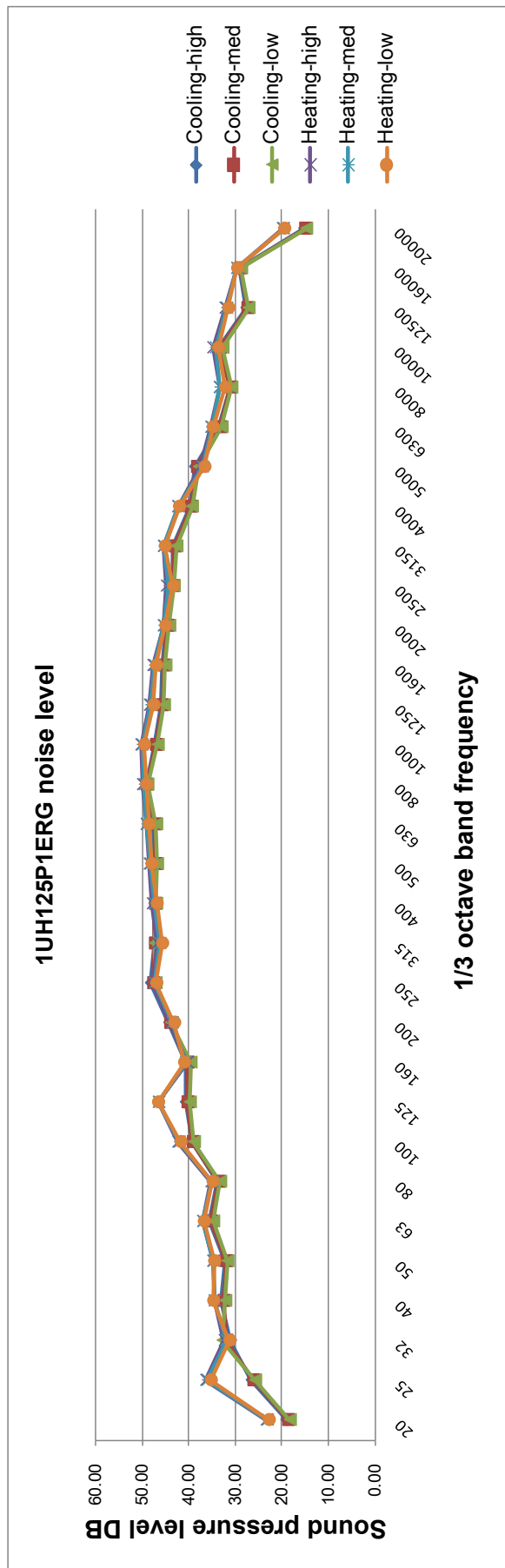

5.5 1UH125P1ERK

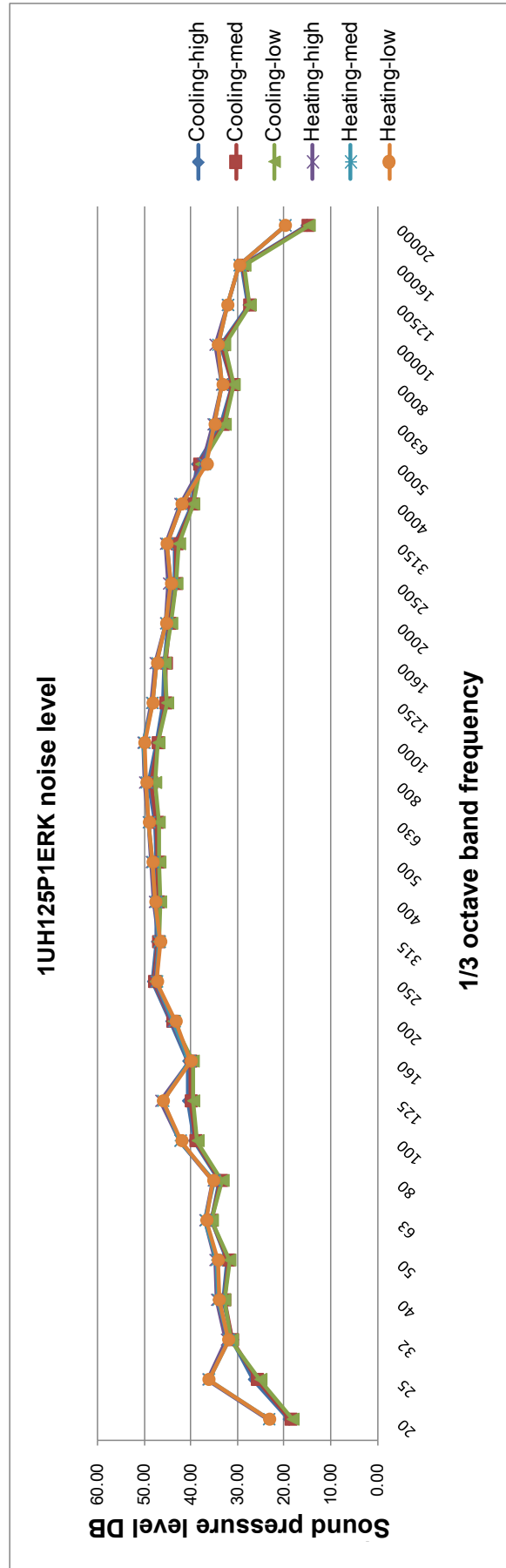

## 5.6 1UH140P1ERK

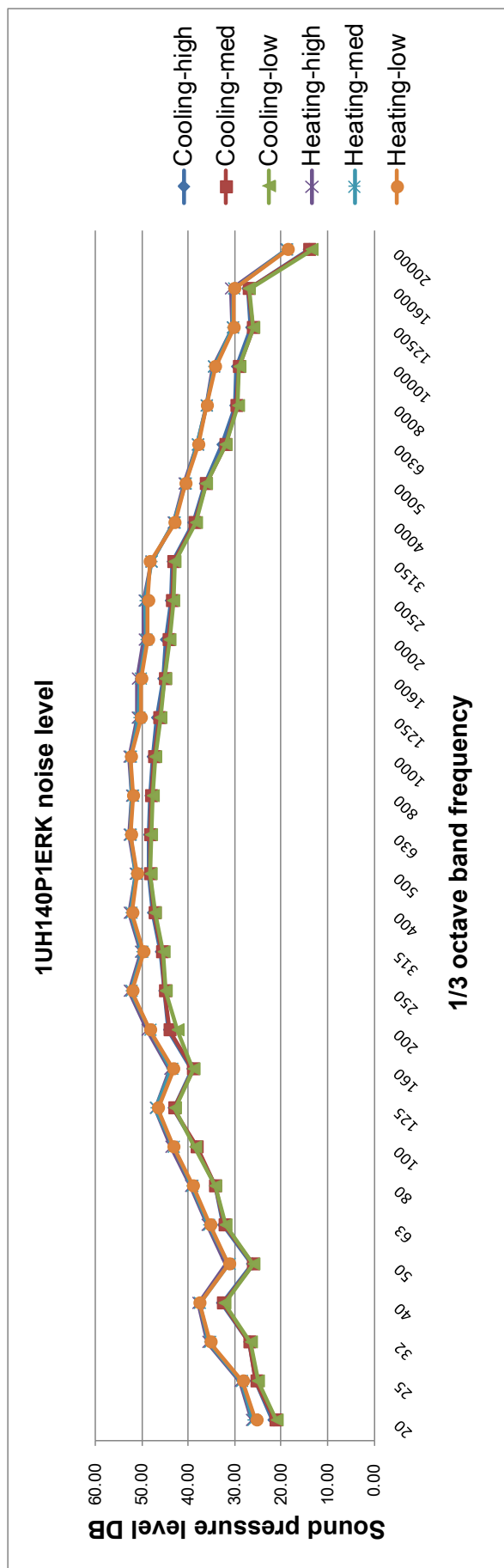

6. Outdoor performance curves

6.1 1UH071N1ERG

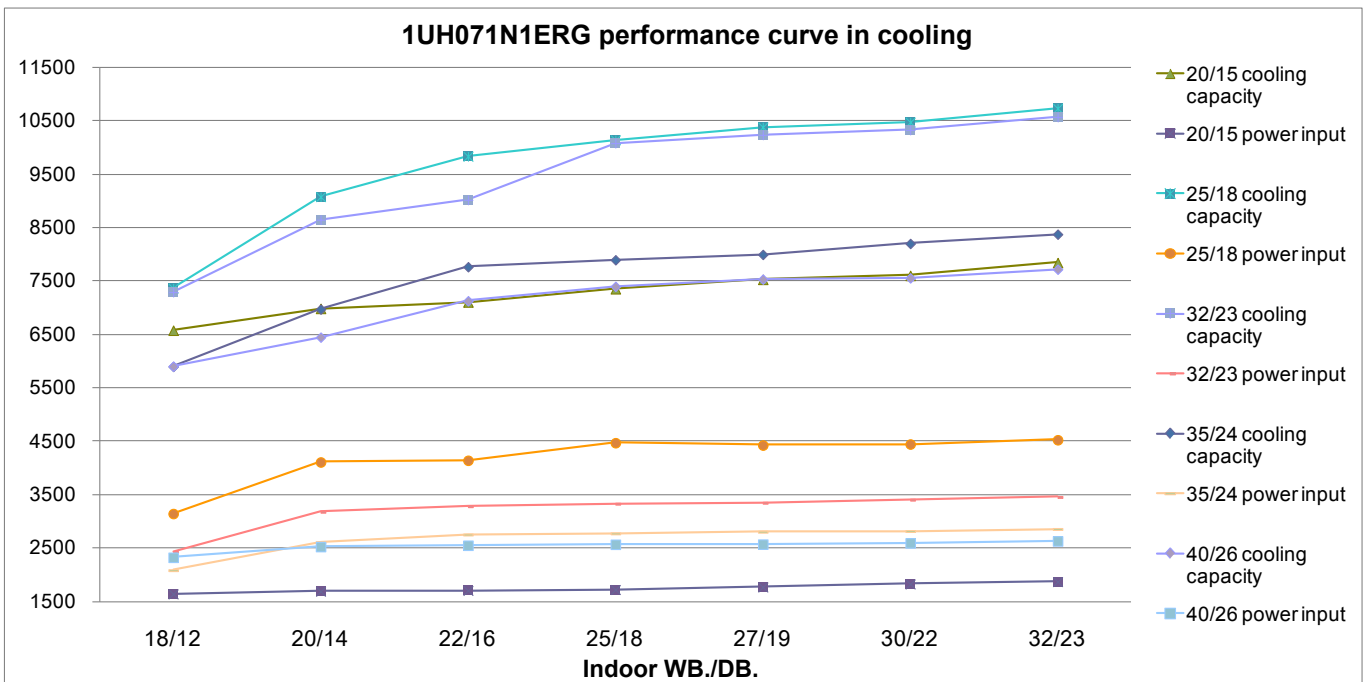
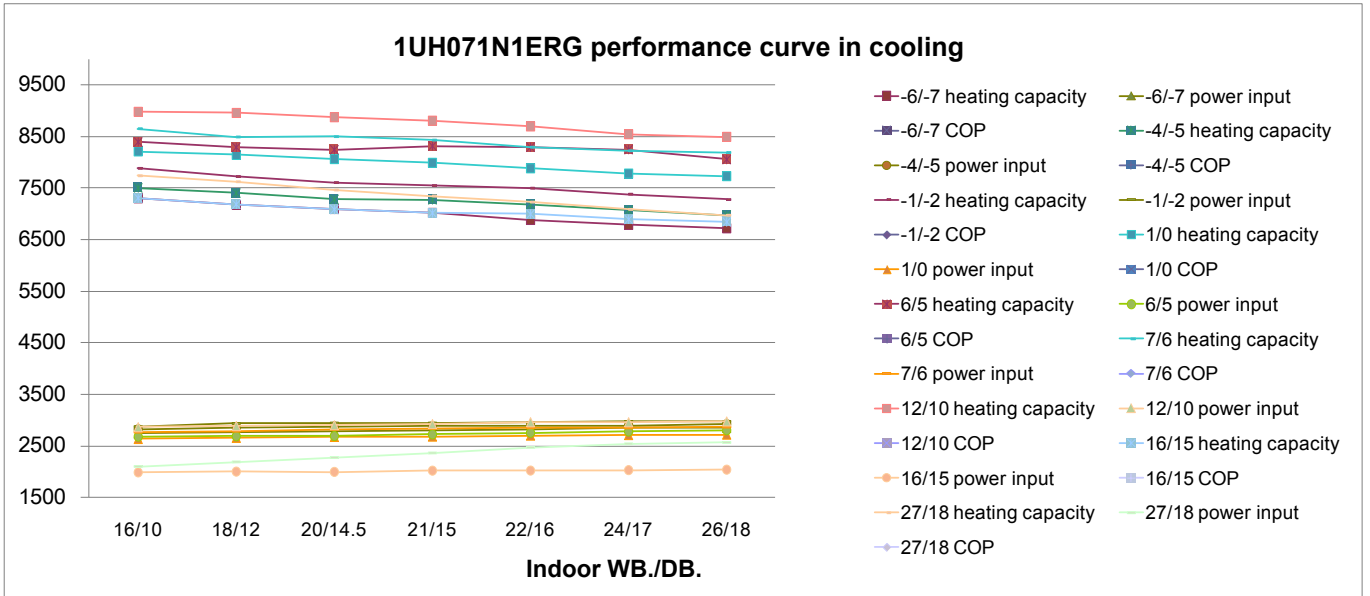

## 6.2 1UH090N1ERG

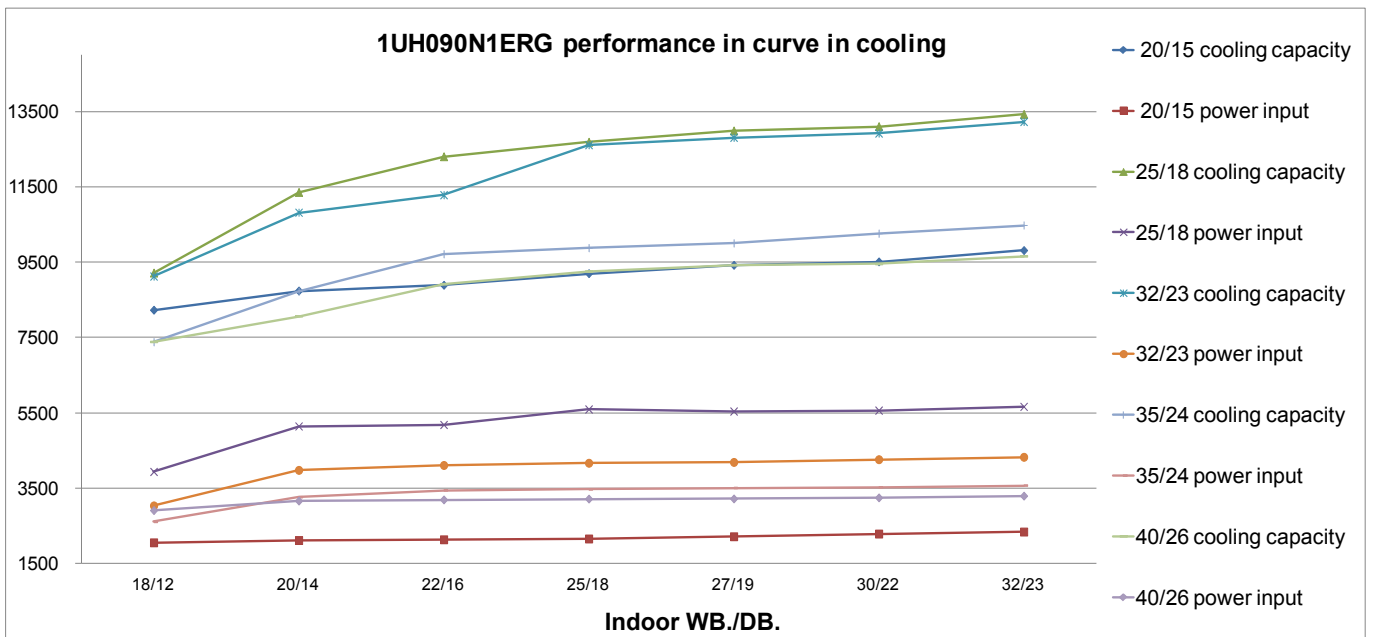
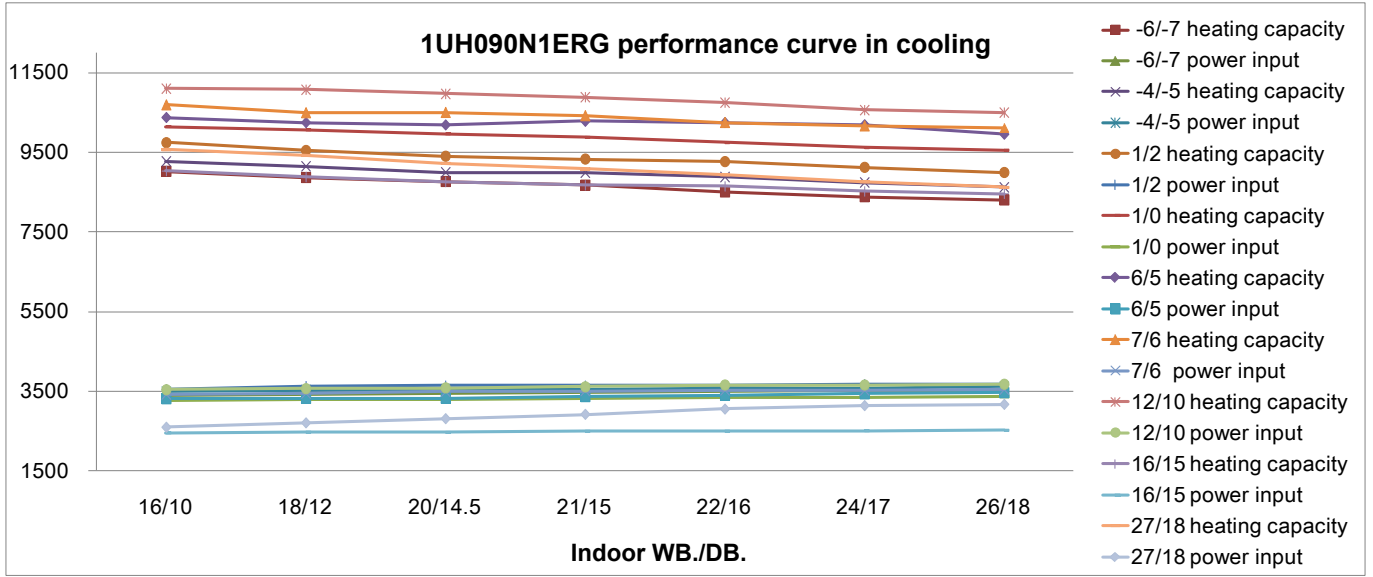



6.3 1UH105N1ERG

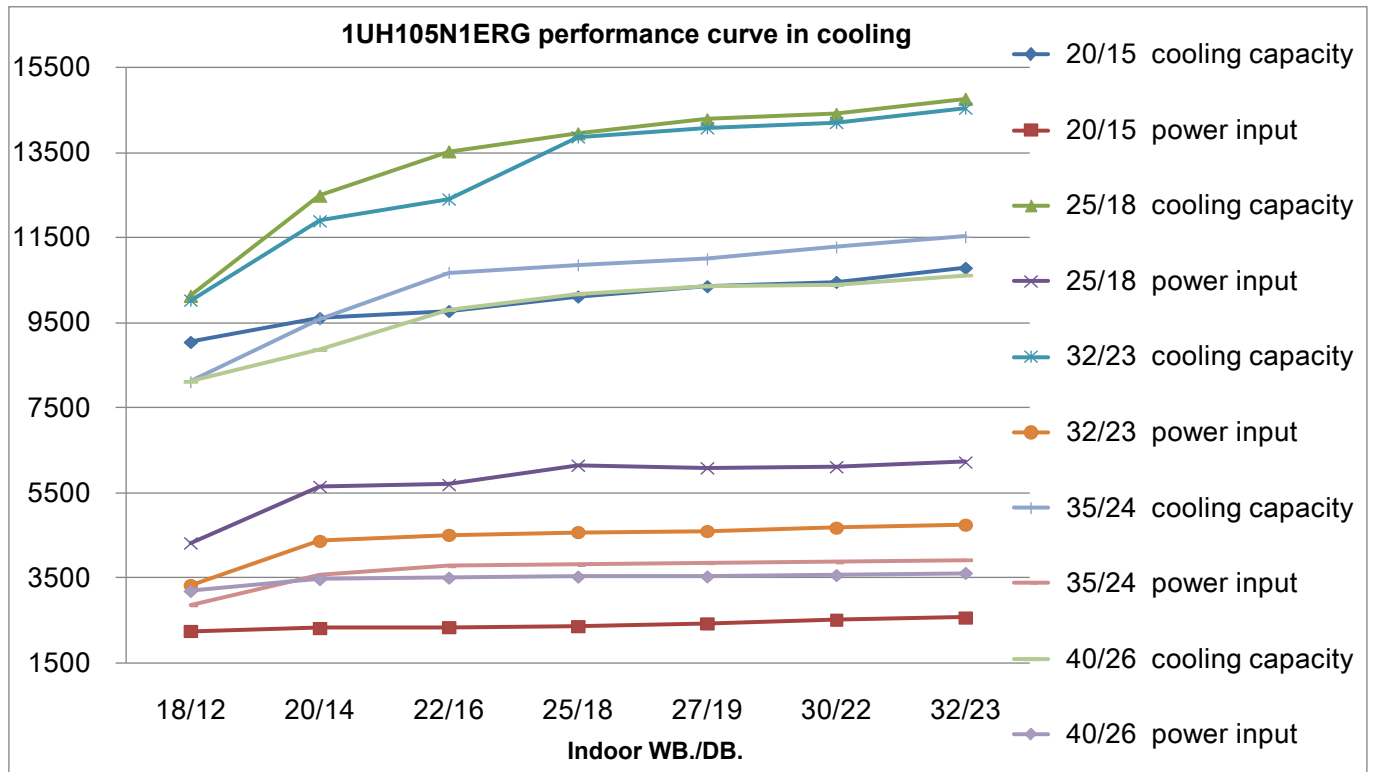
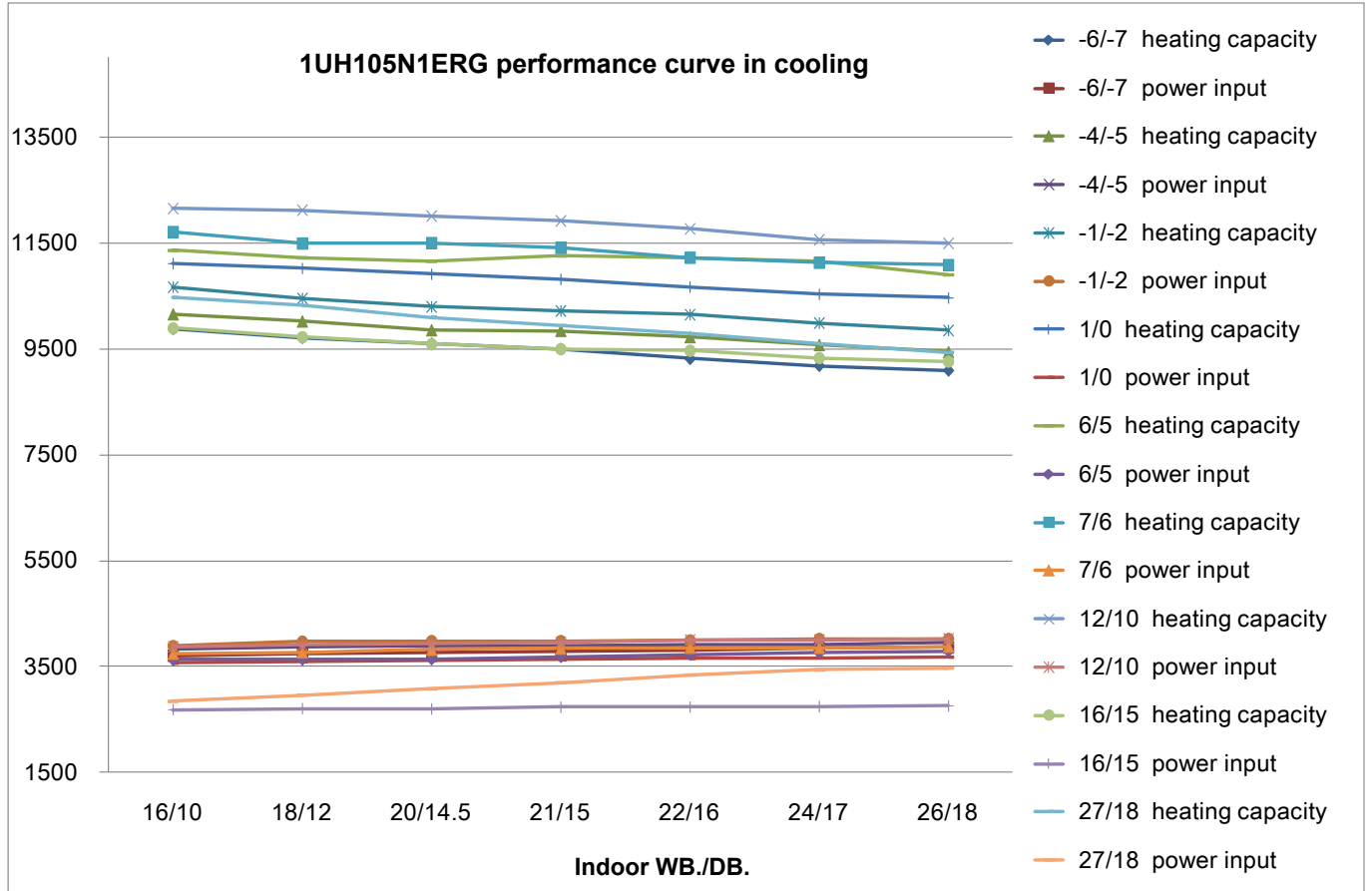

## 6.4 1UH125P1ERG

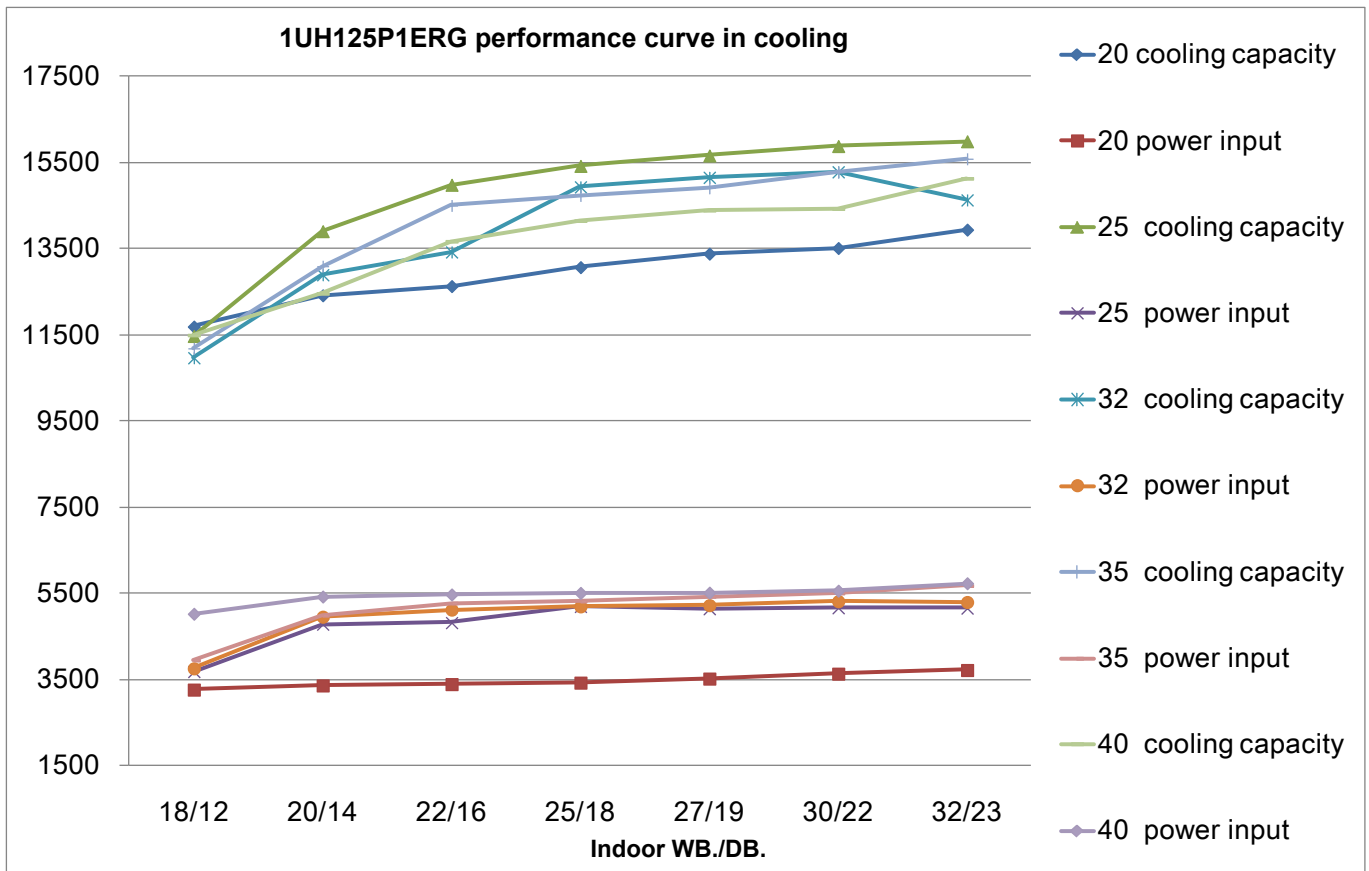
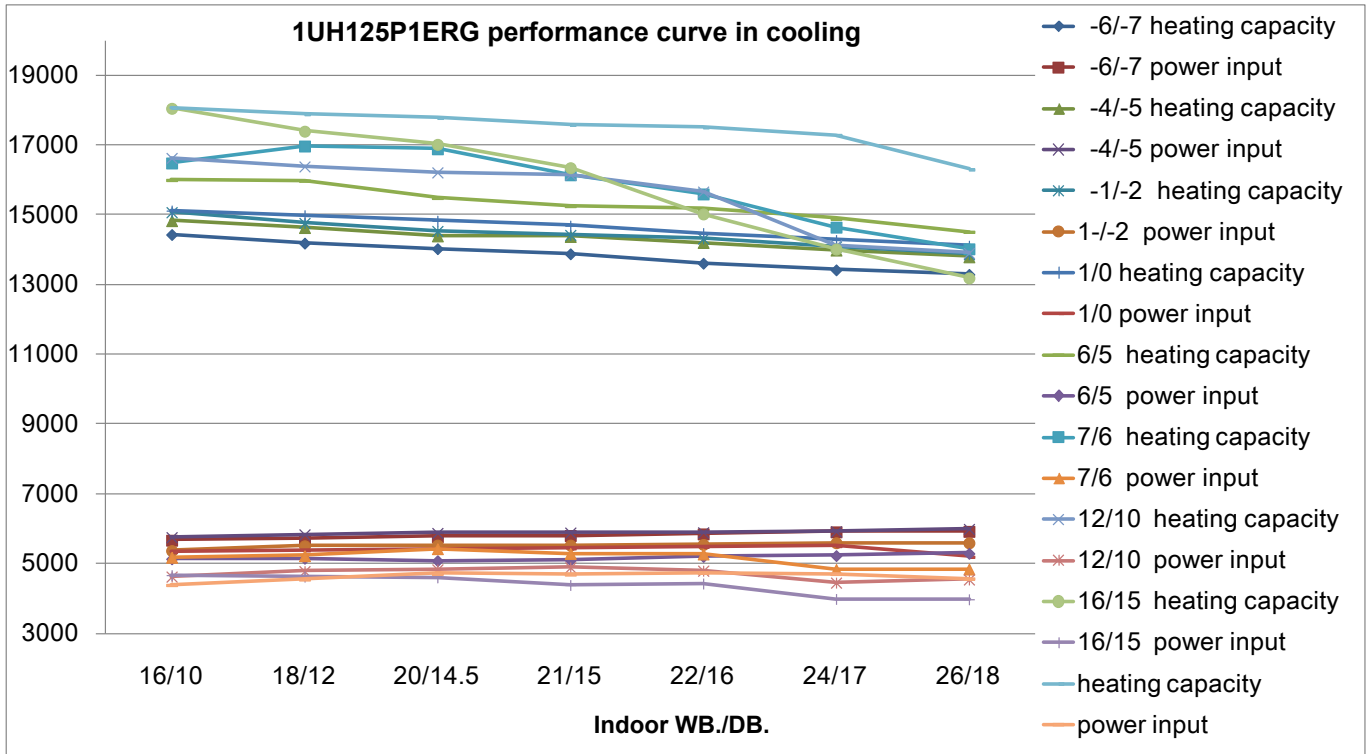

6.5 1UH125P1ERK

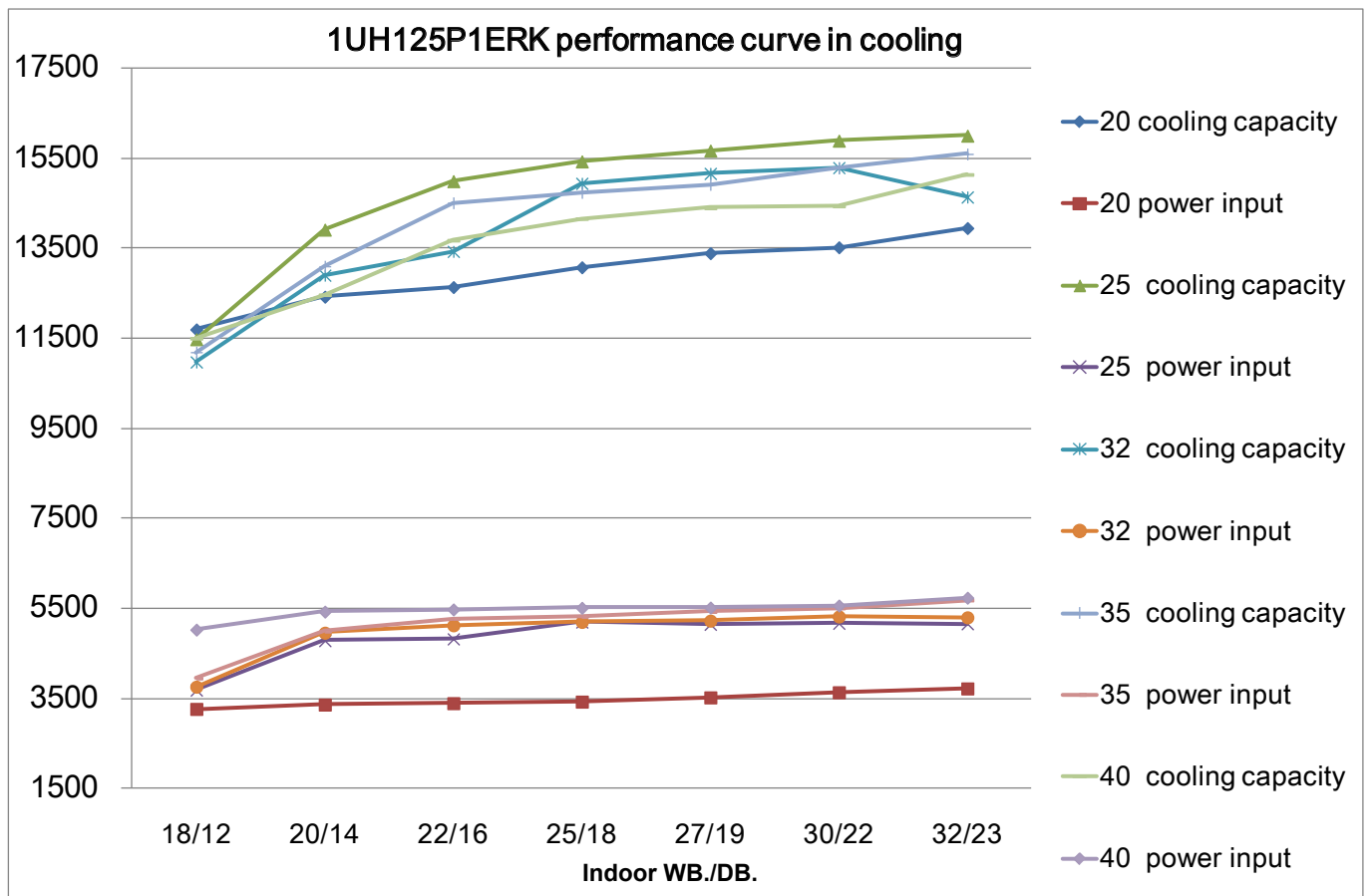
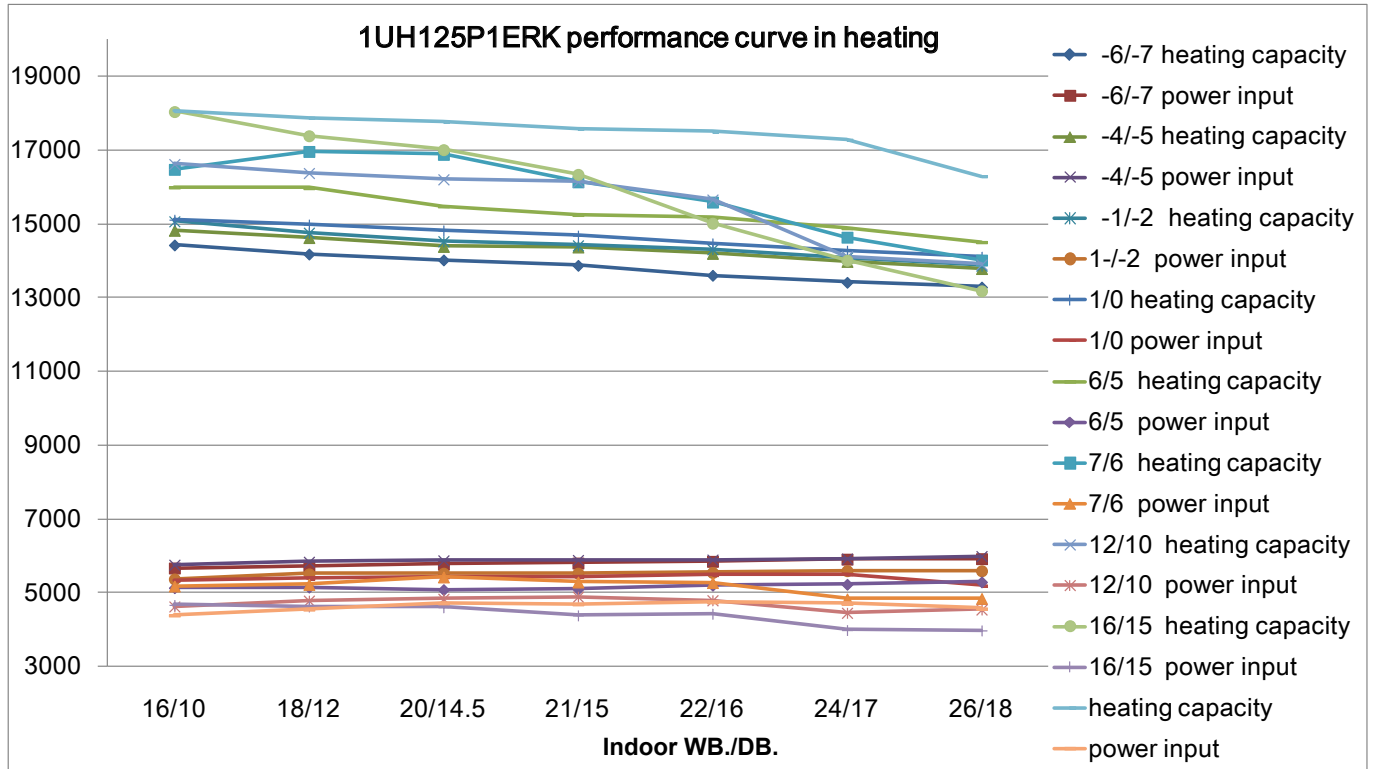

## 6.6 1UH140P1ERK

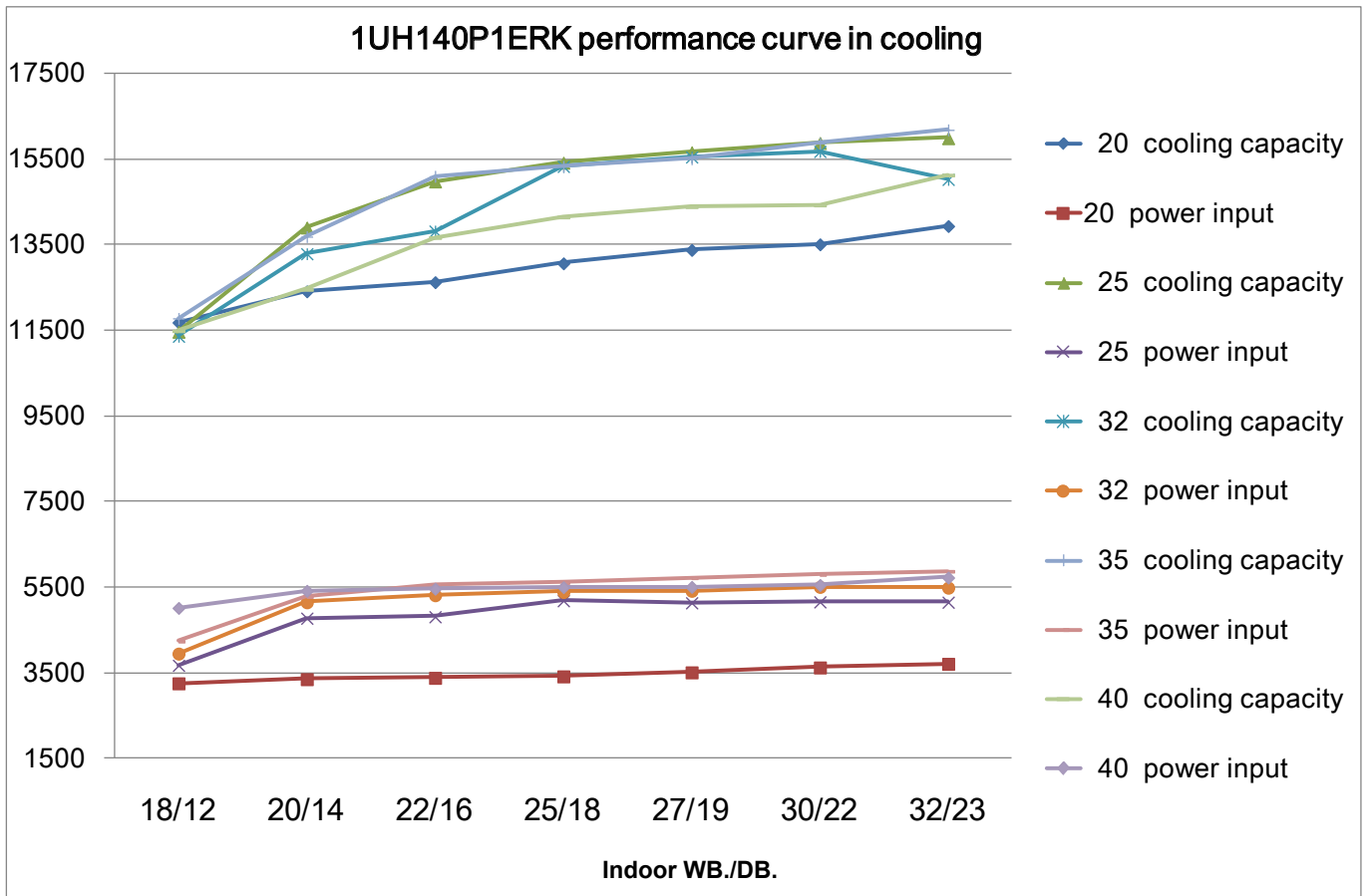
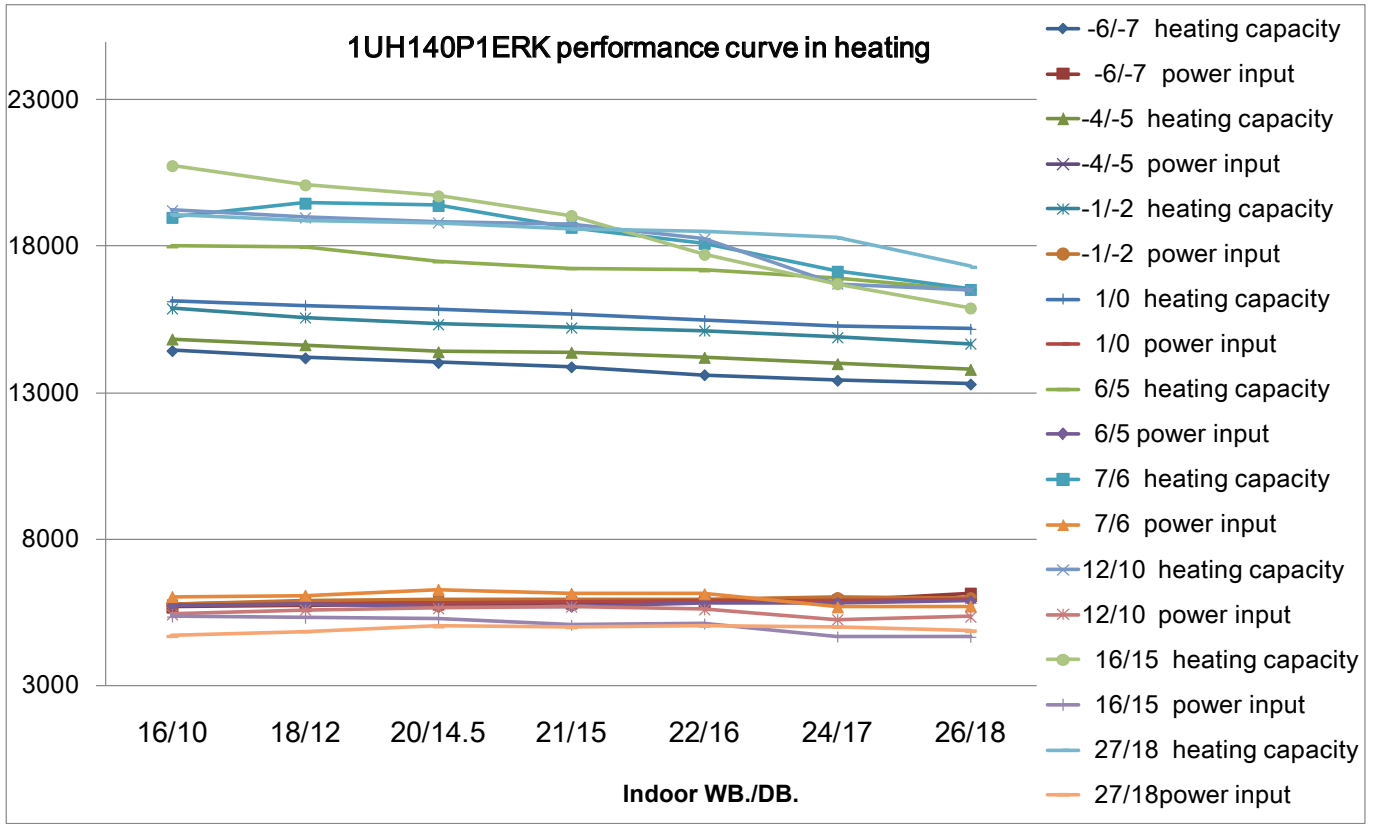

## 7. Installation

### 7.1 Before Installation

#### 7.1.1 Scope of this manual

This manual describes the procedures for handling, installing and connecting 1UH071-140 units.

#### 7.1.2 Precautions

#### CAUTION

Since maximum working pressure is 4.15 MPa or 41.5 bar, pipes of larger wall thickness may be required. Refer to paragraph "8.1. Selection of piping material".

#### NOTICE

Insulation resistance of the compressor

If after installation, refrigerant accumulates in the compressor, the insulation resistance can drop, but if it is at least  $1M\Omega$ , then the machine will not break down. Turn the power on and leave it on for 6h. Then, check if the insulation resistance of the compressor has risen or not.

The compressor will heat up and evaporate any refrigerant in the compressor

Check the following if the ground-fault circuit interrupter is triggered:

Make sure that the interrupter is compatible with high frequencies.

This unit has an inverter, so an interrupter capable of handling high frequencies is needed to prevent malfunction of the interrupter itself.

#### 7.1.3 Precautions for R410A

- The refrigerant requires strict cautions for keeping the system clean, dry and tight.
  - Clean and dry
 

Foreign materials (including mineral oils or moisture) should be prevented from getting mixed into the system.
  - Tight
 

Read "9. Precautions on refrigerant piping" carefully and follow these procedures correctly.
- Since R410A is a mixed refrigerant, the required additional refrigerant must be charged in its liquid state. (If the refrigerant is in state of gas, its composition changes and the system will not work properly) .
- The connected indoor units must be indoor units designed exclusively for R410A.

#### 7.1.4 Installation

- For installation of the indoor unit (s) , refer to the indoor unit installation manual.
- Illustrations show 1UH140P1ERK outdoor unit type. Other types also follow this installation manual.
- This outdoor unit requires the pipe branching kit (optional) when used as the outdoor unit for the simultaneous operation system. Refer to catalogues for details.
- Never operate the unit with a damaged or disconnected discharge thermistor and suction thermistor, burning of the compressor may occur.
- Be sure to confirm the model name and the serial no. of the outer (front) plates when attaching/detaching the plates to avoid mistakes.
- When closing the service panels, take care that the tightening torque does not exceed 4.1 N.M.

### 7.1.5 Accessories

Check if the following accessories are included with the unit: See the figure below for the location of the accessories.

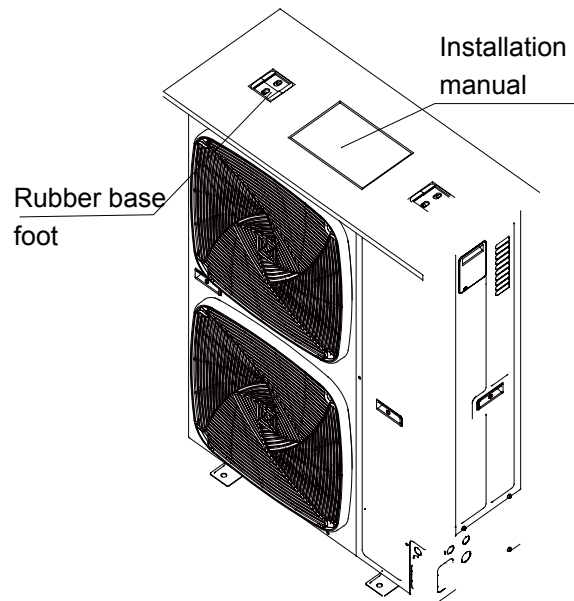

## 7.2 Selecting installation site

### 7.2.1 General

#### WARNING

- Be sure to provide for adequate measures in order to prevent that the outdoor unit be used as a shelter by small animals. Small animals making contact with electrical parts can cause malfunctions, smoke or fire. Please instruct the customer to keep the area around the unit clean.
- Select an installation site where the following conditions are satisfied and that meets with your customer's approval.
  - Places which are well-ventilated.
  - Places where the unit does not bother next-door neighbours.
  - Safe places which can withstand the unit's weight and vibration and where the unit can be installed level.
  - Places where there is no possibility of flammable gas or product leak.
  - The equipment is not intended for using in a potentially explosive atmosphere.
  - Places where servicing space can be well ensured.
  - Places where the indoor and outdoor unit's piping and wiring lengths come within the allowable ranges.
  - Places where water leaking from the unit cannot cause damage to the location (e.g. in case of a blocked drain pipe)
  - Places where the rain can be avoided as much as possible.
  - Do not install the unit in places often used as work place. In case of construction works (d.g.grinding works) where a lot of dust is created, the unit must be covered.
  - Do not place any objects or equipment on top of the unit (top plate) .
  - Do not climb, sit or stand on top of the unit.
  - Be sure that sufficient precautions are taken, in accordance with applicable legislation, in case of refrigerant leakage.

#### NOTICE

This is a class A product. In a domestic environment this product may cause radio interference in which case the user may be required to take adequate measures.

- When installing the unit in a place exposed to strong wind, pay special attention to the following. Strong winds of 5 m/s or more blowing against the outdoor unit's air outlet causes short circuit (suction of discharge air) , and this may have the following consequences:
  - Deterioration of the operational capacity.
  - Frequent frost acceleration in heating operation.
  - Disruption of operation due to rise of high pressure.
  - When a strong wind blows continuously on the face of the unit, the fan can start rotating very fast until it breaks.
 Refer to the figures for installation of this unit in a place where the wind direction can be foreseen.
- Repair a water drainage channel around the foundation, to drain waste water from around the unit.
- If the water drainage of the unit is not easy, please build up the unit on a foundation of concrete blocks, etc. (the height of the foundation should be maximum 150mm) .
- If you install the unit on a frame, please install a waterproof plate (field supply) within 150mm of the underside of the unit in order to prevent the invasion of water from the lower direction. When installing the unit in a place frequently exposed to snow, pay special attention to elevate the foundation as high as possible.
- Make sure that the unit is installed level.

### 7.2.2 General

#### NOTICE

When operating the outdoor unit in a low outdoor ambient temperature, be sure to follow the instructions described below.

- To prevent exposure to wind, install the outdoor unit with its suction side facing the wall.
- Never install the outdoor unit at a site where the suction side may be exposed directly to wind.
- To prevent exposure to wind, install a baffle plate on the air discharge side of the outdoor unit. In heavy snowfall areas it is very important to select an installation site where the snow will not affect the unit and set the outlet side at a right angle to the direction of the wind.

### 7.3 Precautions on installation

#### NOTICE

If drain holes of the outdoor unit are covered by a to provide a free space of more than 130mm under the outdoor unit.

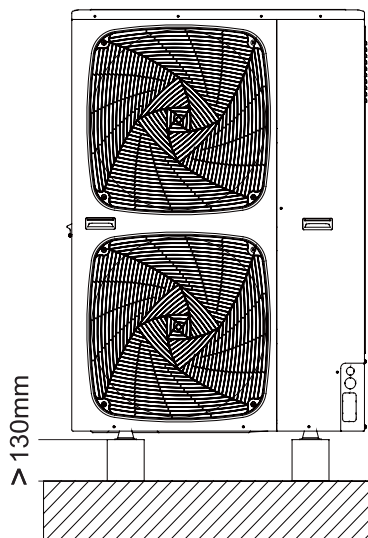

### 7.3.1 Foundation work

- Check the strength and level of the installation ground so that the unit will not cause any operating vibration or noise after installation.
- In accordance with the foundation drawing in the figure, fix the unit securely by means of the foundation bolts. (Prepare four sets of M12 foundation bolts, nuts and washers each which are available on the market.)
- It is best to screw in the foundation bolts until their length are 20mm from the foundation surface.

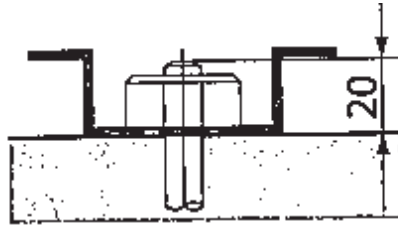

- Fix the outdoor unit to the foundation bolts using nuts with resin washers (1) as shown in the figure.



If the coating on the fastening area is stripped off, the nuts rust easily.  
 Dimensions (bottom view) (unit of measurement:mm)

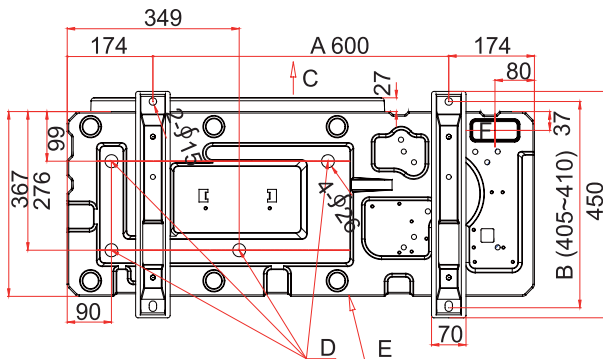

- A. leg pitch1
- B. leg pitch2
- C. Front grill (air outlet side)
- D. Drain hole
- E. Bottom frame
- F. Knock-out hole (for piping line)

### 7.3.2 Selection of installation location of outdoor

#### (1) Single-unit installation (unit: mm)

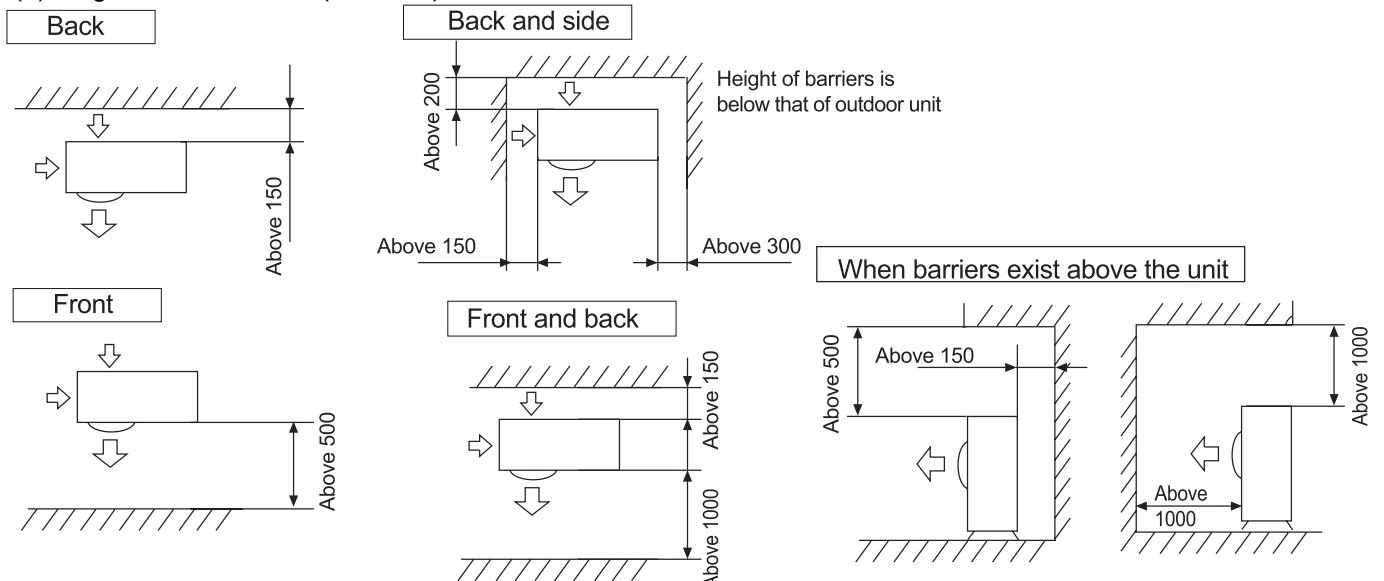

The top and two side surfaces must be exposed to open space, and barriers on at least one side of the front and back shall be lower than the outdoor unit.



(2) Multi-unit installation (unit: mm)

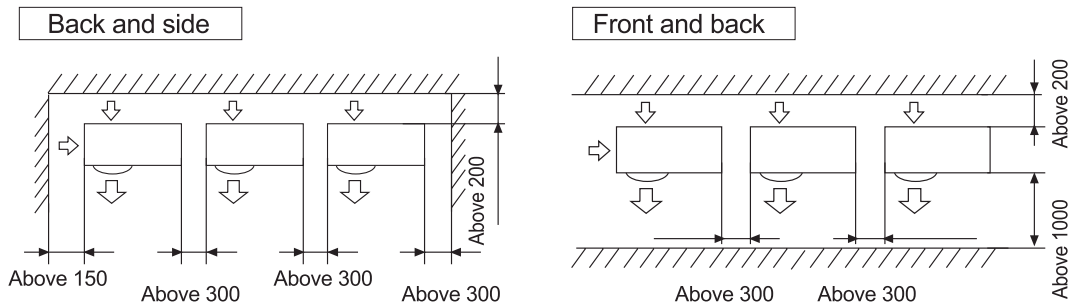

(3) Multi-unit installation in front and back (unit: mm)

Standard

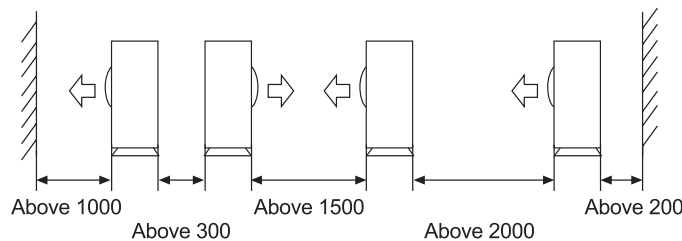

The top and two side surfaces must be exposed to open space, and barriers on at least one side of the front and back shall be lower than the outdoor unit.

- The installation service spaces shown in the illustrations are based on an air intake temperature of 35 (DB) for COOL operation. In regions where the air intake temperature regularly exceeds 35 (DB) , or if the heat load of outdoor units is expected to regularly exceed the maximum operating capacity, reserve a larger space than that indicated at the air intake side of units.
- Regarding the required air outlet space, position the units with consideration to the space required for the onsite refrigerant piping work as well. Consult your dealer if the work conditions do not match those in the drawings.

7.3.3 Drain pipe disposal

- Make sure the drain works properly.
- In regions where buildups of snow can be expected, the accumulation and freezing of snow in the space between the heat exchanger and external plate may lower operating efficiency
- After punching the knock-out hole, the application of repair-type paint on the surface around the edge sections is recommended to prevent rust.

7.4 Refrigerant pipe size and allowable pipe length

**⚠ DANGER**

- Piping an other pressure containing parts shall comply with the applicable legislation and shall be suitable for refrigerant. Use phosphoric acid deoxidised seamless copper for refrigerant.
- Installation shall be done by an installer, the choice of materials and installation shall comply with applicable legislation. In Europe the EN378 is the application standard that shall be used.

**⚠ INFORMATION**

It is forbidden to discharge refrigerant into the atmosphere. Collect the refrigerant in accordance with the freon collection and destruction law.

**⚠ NOTICE**

To persons in charge of piping work:

Be sure to open the stop valve after piping installing and vacuuming is complete. (Running the system with the valve closed may break the compressor.)

### NOTICE

Do not use flux when brazing the refrigerant piping. For brazing, use phosphor copper brazing filler metal (BCuP) which does not require a flux.

(If a chlorine flux is used, the piping will corrode, and if the flux contains fluoride, it will cause the coolant oil to deteriorate, adversely affecting the coolant piping system.)

#### 7.4.1 Necessary Tools and Materials

Prepare the following tools and materials necessary for installing and servicing the unit. Necessary tools for use with R410A (Adaptability of tools that are for use with R22 and R407°C).

##### 1. To be used exclusively with R410A (Not to be used if used with R22 or R407°C)

Tools/Materials	Use	Notes
Gauge manifold	Evacuating, refrigerant charging	5.09MPa on the High-pressure side.
Charging hose	Evacuating, refrigerant charging	Hose diameter larger than the conventional ones.
Refrigerant recovery equipment	Refrigerant recovery	
Refrigerant cylinder	Refrigerant charging	Write down the refrigerant type. Pink in color at the top of the cylinder.
Refrigerant cylinder charging port	Refrigerant charging	Hose diameter larger than the conventional ones.
Flare nut	Connecting the unit to piping	Use Type-2 Flare nuts.

##### 2. Tools and materials that may be used with R410 with some restrictions

Tools/Materials	Use	Notes
Gas leak detector	Detection of gas leaks	The ones for HFC type refrigerant may be used.
Vacuum pump	Vacuum drying	May be used if a reverse flow check adaptor is attached.
Flare tool	Flare machining of piping	Changes have been made in the flare machining dimension. Refer to the next page.
Refrigerant recovery equipment	Recovery of refrigerant	May be used if designed for use with R410A.

##### 3. Tools and materials that are used with R22 or R407°C that can also be used with R410A

Tools/Materials	Use	Notes
Vacuum pump with a check valve	Vacuum drying	
Bender	Bending pipes	
Torque wrench	Tightening flare nuts	Only 12.70 (1/2") and 15.88 (5/8") have a larger flare machining dimension.
Pipe cutter	Cutting pipes	
Welder and nitrogen cylinder	Welding pipes	
Refrigerant charging meter	Refrigerant charging	
Vacuum gauze	Checking vacuum degree	

##### 4. Tool and materials that must not be used with R410A

Tools/Materials	Use	Notes
Charging cylinder	Refrigerant charging	Must not be used with R410-type units.

Tools for R410A must be handled with special care, and keep moisture and dust from entering the cycle.

## 7.4.2 Piping Materials

### Types of Copper Pipes (Reference)

Maximum Operation Pressure	Applicable Refrigerants
3.4MPa	R22, R407C
4.15MPa	R410A

- Use pipes that meet the local standards.

### Piping Materials/Radial Thickness

Use pipes made of phosphorus deoxidized copper.

Since the operation pressure of the units that use R410A is higher than that of the units for use with R22, use pipes with at least the radial thickness specified in the chart below. (Pipes with a radial thickness of 0.7mm or less may not be used.)

Size (mm)	Size (inch)	Radial Thickness (mm)	Type
Φ6.35	1/4"	0.8t	Type-O pipes
Φ9.52	3/8"	0.8t	
Φ12.7	1/2"	0.8t	
Φ15.88	5/8"	1.0t	
Φ19.05	3/4"	1.0t	Type-1/2H or H pipes

- Although it was possible to use type-O for pipes with a size of up to 19.05 (3/4") with conventional refrigerants, use type- 1/2H pipes for units that use R410A. (Type-O pipes may be used if the pipe size is 19.05 and the radial thickness is 1.2t.)
- The table shows the standards in Japan. Using this table as a reference, choose pipes that meet the local standards.

### Flare Machining (type-O and OL only)

The flare machining dimensions for units that use R410A is larger than those for units that use R22 in order to increase air tightness.

### Flare Machining Dimension (mm)

External dimension of pipes	Size	Dimension A	
		R410A	R22
Φ6.35	1/4"	9.1	9.0
Φ9.52	3/8"	13.2	13.0
Φ12.7	1/2"	16.6	16.2
Φ15.88	5/8"	19.7	19.4
Φ19.05	3/4"	24.0	23.3

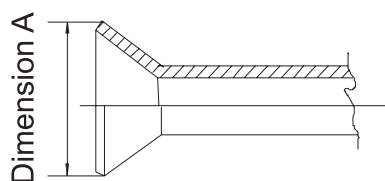

If a clutch type flare tool is used to machine flares on units that use R410A, make the protruding part of the pipe between 1.0 and 1.5mm. Copper pipe gauge for adjusting the length of pipe protrusion is useful.

## Flare Nut

Type-2 flare nuts instead of type-1 nuts are used to increase the strength. The size of some of the flare nuts have also been changed.

Flare nut dimension (mm)

External dimension of pipes	Size	Dimension B	
		R410A (Type2)	R22 (Type1)
Φ6.35	1/4"	17.0	17.0
Φ9.52	3/8"	22.0	22.0
Φ12.7	1/2"	26.0	24.0
Φ15.88	5/8"	29.0	27.0
Φ19.05	3/4"	36.0	36.0

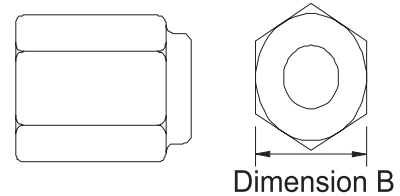

- Using this table as a reference, choose pipes that meet the local standards.

## ⚠ NOTICE

- For new installations, use the standard pipe sizes. When using existing pipes, size-up is allowed as mentioned in the table above.

Additional restrictions towards allowable pipe lengths, as mentioned in the table "Allowable pipe length and height difference" on page 11, must be taken into account.

Not using the standard pipe size may result in capacity decrease. The installer must acknowledge this and judge this very carefully in function of the complete installation.

- Existing or pre-installed piping can be used
  1. Piping must comply with the criteria below.
    - Piping diameter must comply with the limitations as indicated in paragraph "7.2. Refrigerant pipe size" on page 11.
    - Piping length must be within limits of the allowable piping length as in paragraph "7.3. Allowable pipe length and height difference" on page 11.
    - Piping must be designed for R410A. See paragraph "6.2. Selection of piping material" on page 10.

### 2. Piping can be reused without cleaning when:

- Total 1-way piping length: <50m.
- No compressor breakdown has occurred in the history of the unit to be replaced.
- A correct pump down operation can be executed:
  - Operate the unit continuously for 30 minutes in cooling mode.
  - Execute a pump down operation.
  - Remove the air conditioning units to be replaced
- Check the contamination inside the existing piping.

If you cannot meet all these requirements, the existing pipes must be cleaned or replaced after removing the air conditioning units to be replaced.

### 3. Prepare the flare connections for higher pressure. See paragraph 6.2

## Cautions on handling the stem cap

- The stem cap is sealed where indicated by the arrow. Take care not to damage it. After handling the stop valve, make sure to tighten the stem cap securely. For the tightening torque, refer to the table below. Check for refrigerant leaks after tightening the stem cap.

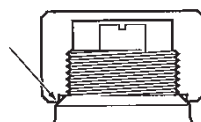

**Cautions on handling the service port**

- Always use a charge hose equipped with a valve depressor pin, since the service port is a Schrader type valve.
- After handling the service port, make sure to tighten the service port cap securely. For the tightening torque, refer to the table below.
- Check for refrigerant leaks after tightening the service port cap.

**7.5 Refrigerant piping**

7.5.1 Piping diagram for single split

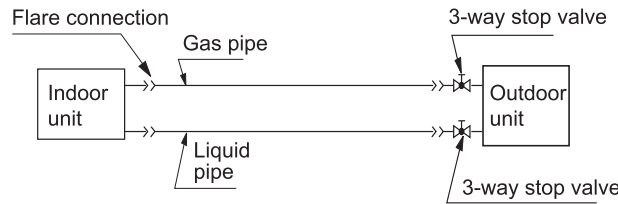

7.5.2 Piping size for single split

Model	Pipe	Diameter of pipe
1UH071N1ERG 1UH090N1ERG 1UH105N1ERG	Liquid pipe	ø9.52mm
1UH125P1ERG 1UH125P1ERK 1UH140P1ERG 1UH140P1ERK	Gas pipe	ø15.88mm

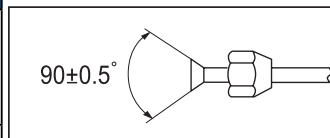

Install the removed flare nuts to the pipes to be connected, then flare the pipes.

7.5.3 Limitations for one way piping length and vertical height difference for single split

Model	1UH071N1ERG 1UH090N1ERG 1UH105N1ERG	1UH125P1ERG 1UH125P1ERK 1UH140P1ERG 1UH140P1ERK
One way piping length	less than 50 m	less than 75 m
Vertical height difference (between indoor and outdoor)	less than 30 m	less than 30 m
Maximum pipe length without recharge refrigerant	20m	30m

Precautions for refrigerant piping

- Do not twist or crush piping.
- Be sure that no dust is mixed in piping.
- Bend piping with as wide angle as possible.
- Keep insulating both gas and liquid piping.
- Check flare-connected area for gas leakage.

### 7.5.4 Piping connection method

- Apply refrigerant oil to the joint and the flange.
- To bend a pipe, give the roundness as possible not to crush the pipe.
- When connecting pipe, hold the pipe centre to centre and then screw nut on by hand, refer to Fig.
- Be careful not to let foreign matters, such as sands enter the pipe

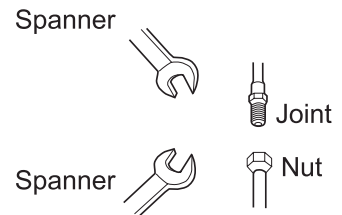

Pipe diameter	Fastening torque (N.m)
Liquid pipe $\Phi 6.35\text{mm}$	14.2-17.2
Liquid pipe $\Phi 9.52\text{mm}$	32.7-39.9
Gas pipe $\Phi 12.7\text{mm}$	49.5-60.3
Gas pipe $\Phi 15.88\text{mm}$	61.8-75.4
Gas pipe $\Phi 19.05\text{mm}$	97.2-118.6

- Field pipes can be installed in four directions (A, B, C, D, E).

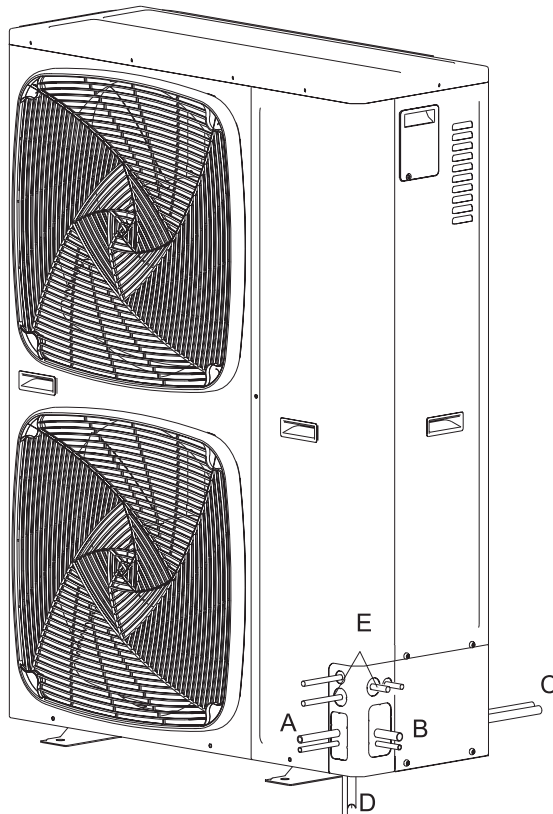

- A: Forward
- B: Backward
- C: Sideways
- D: Downward
- E: Power supply cable, outdoor and indoor connection cable

- Cutting out the two slits makes it possible to install as shown in the figure "Field pipes in 4 directions". (Use a metal saw to cut out the slits.)
- To install the connecting pipe to the unit in a downward direction, make a knock-out hole by penetrating the centre area around the knock-out hole using a 6mm drill (4x). (See figure "Field pipes in 4 directions".)
- After knocking out the knock-out hole, it is recommended to apply repair paint to the edge and the surrounding end surfaces to prevent rusting.
- When passing electrical wiring through the knock-out holes, remove any burrs from the know-out holes and wrap the wiring with protective tape to prevent damage.

### 7.5.5 Preventing foreign objects from entering

Plug the pipe through-holes with putty or insulating material (procured locally) to stop up all gaps, as shown in the figure.

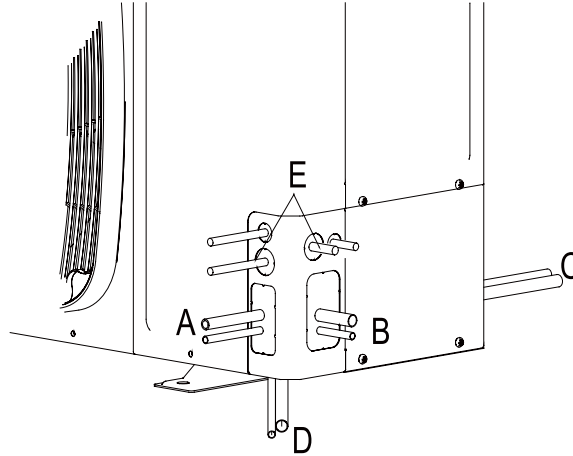

1 Putty or insulating material (produced locally)

If there is any possibility that small animals enter the system through the knock-out holes, plug the holes with packing materials (field supplied) .

Insects or small animals entering the outdoor unit may cause a short circuit in the electrical box

Seal knock-out holes to avoid snow and humidity entering.

### 7.5.6 Preventing foreign objects from entering

- Be careful not to let the indoor and outdoor piping come into contact with the compressor terminal cover. If the liquid-side piping insulation might come into contact with it, adjust the height as shown in the figure below. Also, make sure the field piping does not touch the bolts or outer panels of the compressor.
- When the outdoor unit is installed above the indoor unit the following can occur:  
The condensed water on the stop valve can move to the indoor unit. To avoid this, please cover the stop valve with sealing material.
- If the temperature is higher than 30 and the humidity is higher than RH 80 , then thickness of the sealing materials should be at least 20mm in order to avoid condensation on the surface of the sealing.
- Be sure to insulate the liquid and gas-side field piping.

#### NOTICE

Any exposed piping may cause condensation.

(The highest temperature that the gas-side piping can reach is around 120, so be sure to use insulating material which is very resistant.)

#### DANGER

No not touch piping and internal parts.

### 7.5.7 Cautions for necessity of a trap

To avoid the the risk of oil held inside the riser piping flowing back into the compressor when stopped and causing liquid compression phenomenon, or cases of deterioration of oil return, it will be necessary to provide a trap at each difference in height of 10m in the riser gas piping.

- A trap is not necessary when the outdoor unit is installed at higher position than the indoor unit.

## 7.6 Leak test and vacuum drying

When all piping work is complete and the outdoor unit is connected to the indoor unit, it is necessary to :

- Check for any leakages in the refrigerant piping
- To perform vacuum drying to remove all moisture in the refrigerant piping.

If there is a possibility of moisture being present in the refrigerant piping (for example, rainwater may have entered the piping) , first carry out the vacuum drying procedure below until all moisture has been removed.

### 7.6.1 General guidelines

- All piping inside the unit has been factory tested for leaks.
- Use a 2-stage vacuum pump with a non-return valve which can evacuate to a gauge pressure of -100.7kPa (5 Torr absolute, -755mm Hg) .
- Connect the vacuum pump to both the service port of the gas stop valve and the liquid stop valve to increase

### NOTICE

- Do not purge the air with refrigerants. Use a vacuum pump to evacuate the installation. No additional refrigerant is provided for air purging.  
Make sure that the gas stop valve and liquid stop valve are firmly closed before performing the leak test or vacuum drying.

### 7.6.2 Leak test

The leak test must satisfy specification EN378-2.

#### 1. Vacuum leak test

- 1.1 Evacuate the system from the liquid and gas piping to -100.7 kPa (5 Torr) .
- 1.2 Once reached, turn off the vacuum pump and check that the pressure does not rise for at least 1 minute.
- 1.3 Should the pressure rise, the system may either contain moisture (refer to the paragraph " Vacuum drying ") or have leaks.

#### 2. Pressure leak test

- 2.1 Break the vacuum by pressurizing with nitrogen gas to a minimum gauge pressure of 0.2 MPa (2 bar) . Never set the gauge pressure higher than the maximum operation pressure of the unit, i.e. 4.0MPa (40bar) .
- 2.2 Test for leaks by applying a bubble test solution to all piping connections.

### NOTICE

Make sure to use a recommended bubble test solution from your wholesaler.

Do not use soap water, which may cause cracking of flare nuts (soap water may contain salt, which absorbs moisture that will freeze when the piping gets cold) . and/or lead to corrosion of flared joints (soap water may contain ammonia which causes a corrosive effect between the brass flare nut and the copper flare) .

### 7.6.3 Vacuum drying

To remove all moisture from the system, proceed as follows:

1. Evacuate the system for at least 2 hours to a target vacuum of -100.7 kPa (= -1.007 bar) .
2. Check that, with the vacuum pump turned off, the target vacuum is maintained for at least 1 hour.
3. Should you fail to reach the target vacuum within 2 hours or maintain the vacuum for 1 hour, the system may contain too much moisture.
4. In that case, break the vacuum by pressurizing with nitrogen gas to a gauge pressure of 0.05 MPa (0.5bar) and repeat steps 1 to 3 until all moisture has been removed.
5. The stop valves can now be opened, and/or additional refrigerant can be charged (See "12. Charging refrigerant" on page 13) .

### INFORMATION

After opening the stop valve, it is possible that the pressure in the refrigerant piping does not rise. This might be caused by e.g. the closed state of the expansion valve in the outdoor unit circuit, but does not present any problem for correct operation of the unit.



**7.7 Charging refrigerant**

**7.7.1 Important information regarding the refrigerant used**

This product contains fluorinated greenhouse gases covered by the Kyoto Protocol. Do not vent gases into the atmosphere.

**7.7.2 Precautions and general guidelines**

- When servicing the unit requires the refrigerant system to be opened, treatment and evacuation of refrigerant must be done in accordance with applicable legislation.
- Refrigerant can not be charged until field wiring has been completed.  
Refrigerant may only be charged after performing the leak test and vacuum drying

**⚠ CAUTION**

When charging a system, care shall be taken that its maximum permissible charge is never exceeded, in view of the danger of liquid hammer.

**⚠ WARNING**

- Refrigerant cylinders shall be opened slowly.
- Always use protective gloves and protect your eyes when charging refrigerant.

**⚠ DANGER**

- When the power is on, please close the front panel when leaving the unit unattended.  
Charging with an unsuitable substance may cause explosions and accidents, so always ensure that the appropriate refrigerant (R410A) is charged.

- This unit requires additional charging of refrigerant according to the length of refrigerant piping connected at the site.
- Make sure to charge the refrigerant in liquid state to the liquid pipe. Since R410A is a mixed refrigerant, its composition changes if charged in its gaseous state and normal system operation would then no longer be assured.
- Before charging, check whether the refrigerant cylinder has a siphon attached or not and position the cylinder accordingly.

On this model it is not necessary to charge additionally if the piping length ≤ 30m.

Fill using a cylinder with a siphon attached  
Charge the liquid refrigerant with the cylinder in upright position.

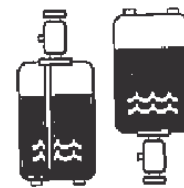

Fill using a cylinder with a siphon attached  
Charge the liquid refrigerant with the cylinder in up-side-down position.

### 7.7.3 Complete recharging

#### **⚠ NOTICE**

Before recharging, make sure to execute vacuum drying of the internal piping of the unit as well. To do so, use the internal service port of the unit. Do not use the service ports located on the stop valve (see "9.3. Stop valve operation" on page 10) , since vacuum drying can not be performed properly from these ports. Outdoor units have 1 port on the piping. It is between the heat exchanger and the 4-way valve.

In case complete recharging is required (after a leak, etc.) , refer to teh information below to determine the necessary amount of refrigerant.

#### **⚠ WARNING**

Some sections of the refrigerant circuit may be isolated from other sections caused by components with specific functions (e.g. valves) . The refrigerant circuit therefore features additional service ports for vacuuming, pressure relief or pressurizing the circuit. In case it is required to perform brazing on the unit, ensure that there is no pressure remaining inside the unit. Internal pressures need to be released with ALL the service ports indicated on the figures below opened. The location is depending on mode type.

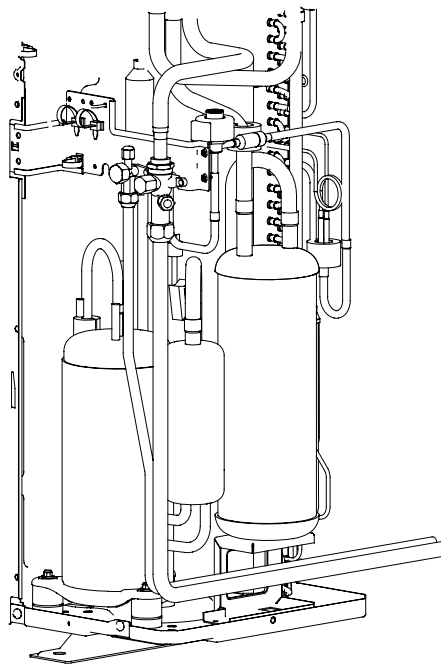

### 7.7.4 Total charging weight of the refrigerant (after a leak, etc.)

The total charging amounts relate to the refrigerant piping length as in "Maximum total one-way piping length" of the table in paragraph "8.4. Allowable pipe length and height difference" on page 8. (E.g. twin: L1+L2)/

Model	Refrigerant piping length (liquid side)							
	5-10m	10-20m	20-30m	30-40m	40-50m	50-60m	60-70m	70-80m
1UH071N1ERG 1UH090N1ERG	2.5	2.5	2.5	2.95	3.4	-	-	-
1UH105N1ERG	2.5	2.5	2.5	2.95	3.4	3.85	-	-
1UH125P1ERG 1UH125P1ERK 1UH140P1ERG 1UH140P1ERK	3.7	3.7	3.7	4.15	4.6	5.05	5.5	5.95

**7.8 Pump down operation**

This unit is equipped with an automatic pump down operation which will collect all refrigerant from the field piping and indoor unit in the outdoor unit. To protect the environment, make sure to perform the following pump down operation when relocating or disposing of the unit.

**⚠ INFORMATION**

For more details, refer to the applicable service manual.

1	Make sure that stop valves both on liquid and on gas side are open.	
2	Push the BS4 pumping-down operation button on the PC board of the outdoor unit (8 seconds) .	Compressor and outdoor fan will start operation automatically. The indoor unit fan may automatically start running. Please pay attention to this.
3	Close the stop valve on the liquid side securely about 2 minutes after the compressor started operation.	Never leave the outdoor unit unattended with opened front panel when power supply is on. In case the stop valve on the liquid side is not securely closed during compressor operation, during compressor operation, pumping-down operation cannot be executed.
4	Once compressor operation stops after 2 to 5 minutes (a) , close the stop valve on the gas side securely.	
5	Turn off the power supply.	

If after finishing pumping-down operation the outdoor unit does not operate, not even when the remote controller switch is turned on, the remote controller may or may not indicate " 04 ". But this is not a malfunction.

When in need of operation, turn off the main power supply and turn it on again. Make sure that stop valves both on liquid and gas side are open and be sure to operate the unit in cooling operation during test run.

**⚠ WARNING**

Make sure to re-open both stop valves before restarting operation of the unit.

**7.9 Electrical wiring work**

**⚠ WARNING**

- All wiring must be performed by an authorized electrician.  
All components procured on the side and all electric construction shall comply with the applicable legislation.

**⚠ DANGER**

**HIGH VOLTAGE**

To avoid electrical shock, make sure to disconnect the power supply 1 minute or more before servicing the electrical parts. Even after 1 minute, always measure the voltage at the terminals of main circuit capacitors or electrical parts and, before touching , make sure that those voltages are 50VDC or less.

**⚠ NOTICE**

To persons in charge of electrical wiring work:

Do not operate the unit until the refrigerant piping is complete. (Running it before the piping is ready will break the compressor.)

### 7.9.1 Precautions on electrical wiring work

- When servicing the unit requires the refrigerant system to be opened, treatment and evacuation of refrigerant must be done in accordance with applicable legislation. Refrigerant can not be charged until field wiring has been completed.

Refrigerant may only be charged after performing the leak test and vacuum drying (see "11. Leak test and vacuum drying" on page 12) .

## DANGER

- Before obtaining access to terminal devices, all supply circuits must be interrupted.
- Be sure to install an earth leakage circuit breaker in accordance with applicable legislation. Failure to do so may cause electrical shock.
- Use only copper wires.
- A main switch or other means for disconnection, having a contact separation in all poles, must be incorporated in the fixed wiring in accordance with applicable legislation. Do not turn on the main switch until all the wiring is completed.
- For Y1
  - Make sure to connect power supply cables in normal phase. If connected in reverse phase, the remote controller of the indoor unit indicates "07 " and the equipment cannot operate. Change any two of the three power supply cables (L1, L2, L3) to correct phase.
  - If the contact in the magnetic switch should be forcibly turned on while the equipment is inoperative, the compressor will burn out. Never try to forcibly turn on the contact.
- Never squeeze bundled cables into a unit.
- Fix cables so that cables do not make contact with the pipes (especially on high pressure side) .
- Secure the electrical wiring with cable ties as shown in the figure in chapter 14.2.
- Make sure no external pressure is applied to the terminal connectors.
- When installing the earth leakage circuit breaker make sure that it is compatible with the inverter (resistant to high frequency electrical noise ) to avoid unnecessary opening of the earth leakage circuit breaker.
- As this unit is equipped with an inverter, installing a phase advancing capacitor not only will deteriorate power factor improvement effect, but also may cause capacitor abnormal heating accident due to high-frequency waves. Therefore, never install a phase advancing capacitor.

## CAUTION

Be sure to install the required fuses or circuit breakers.

7.9.2 Connecting power supply and inter-unit wiring

- Connect and fix the power supply cable, indoor-outdoor connection cable as following:

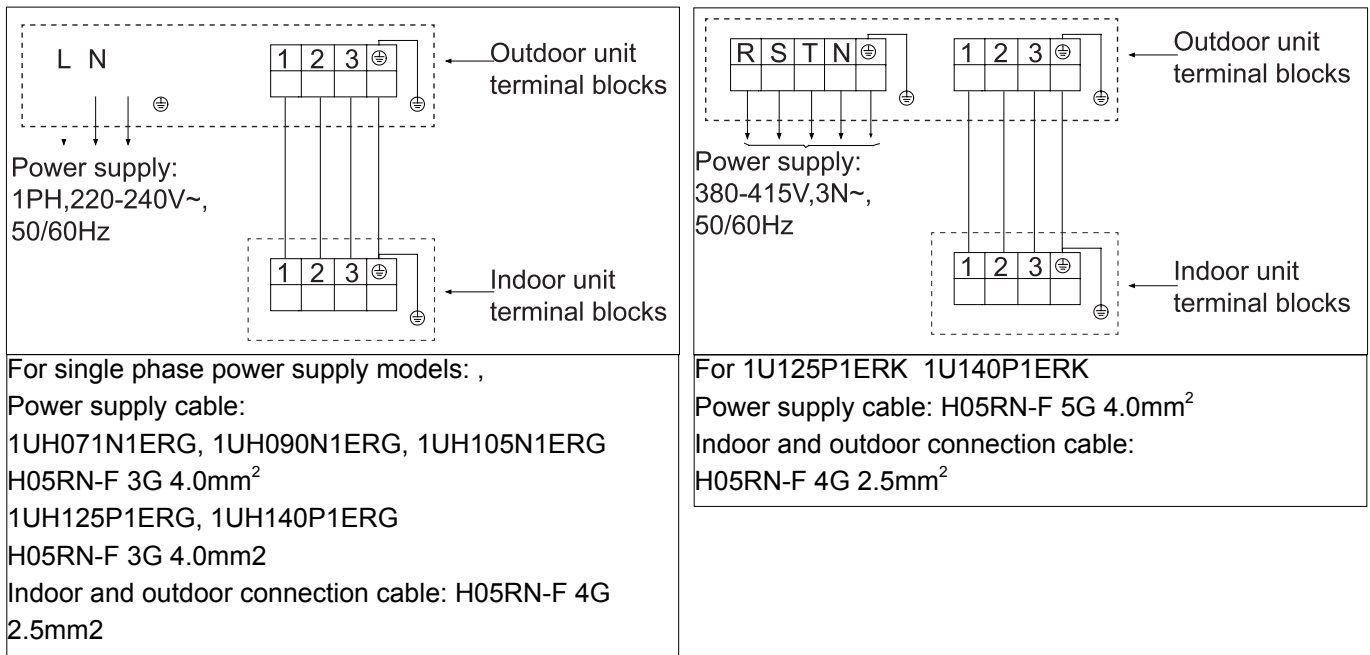

- Fix the cable with the clip to prevent slide.
- Secure the cable to the stop valve attachment plate so that it does not slide.
- When cables are routed from the unit, a protection sleeve for the conduits (PG-insertions) can be inserted at the knock-out hole.
- When you do not use a wire conduit, be sure to protect the wires with vinyl tubes to prevent the edge of the knock-out hole from cutting the wires.
- Follow the electric wiring diagram for electrical wiring works.
- Form the wires and fix the cover firmly so that the cover may be fit in properly.
- When you do not use a wire conduit, be sure to protect the wires with vinyl tubes to prevent the edge of the knock-out hole from cutting the wires.
- Follow the electric wiring diagram for electrical wiring works.
- Form the wires and fix the cover firmly so that the cover may be fit in properly.
- Do not connect wires of different gauge to the same power supply terminal. (Looseness in the connection may cause overheating.)
- Use the correct screwdriver to tighten the terminal screws. Small screwdrivers can damage the screw head and prevent appropriate tightening.
- Over-tightening the terminal screws can damage the screws.

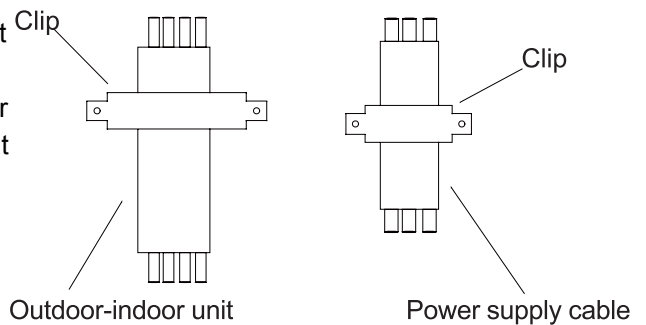

7.9.3 Specifications of standard wiring components

**CAUTION**

- Select all cables and wire sizes in accordance with applicable legislation.
- After finishing the electrical work, confirm that each electric part and terminal inside the electric part box is connected securely.
- The earth leakage breaker must be a high-speed type breaker of 30 mA (<0.1 s) .

### 7.10 Test operation

#### DANGER

Never leave the unit unattended during installation or servicing. When the service panel is removed live parts can be easily touched by accident.

#### INFORMATION

Note that during the first running period of the unit, required power input may be higher than stated on the nameplate of the unit. This phenomenon originates from the compressor that needs elapse of a 50 hours run in period before reaching smooth operation and stable power consumption.

#### 7.10.1 Pre-run checks

Items to check	
Electrical wiring Inter-unit wiring Ground wire	<ul style="list-style-type: none"> <li>■ Is the wiring as mentioned on the wiring diagram? Make sure no wiring has been forgotten and that there are no missing phases or reverse phases.</li> <li>■ Is the unit properly grounded?</li> <li>■ Is the wiring between units connected in series correct? Are any of the wiring attachment screws loose? Is the insulation resistance at least 1MΩ? - Use a 500V mege-tester when measuring insulation. - Do not use a mege-tester for low-voltage circuits.</li> </ul>
Refrigerant piping	<ul style="list-style-type: none"> <li>■ Is the size of the piping appropriate?</li> <li>■ Is the insulation material for the piping attached securely? Are both the liquid and gas pipes insulated?</li> <li>■ Are the stop valves for both the liquid side and the gas side open?</li> </ul>
Extra refrigerant	<ul style="list-style-type: none"> <li>■ Did you write down the extra refrigerant and the refrigerant piping length?</li> </ul>

- Be sure to perform a test run.
- Be sure to fully open the liquid-side and gas-side stop valves. If you operate the unit with stop valves closed, the compressor will break down.
- Be sure to execute the first test run of the installation in cooling mode operation.
- Never leave the unit unattended with an open front panel during test run.

#### 7.10.2 Precautions regarding test-runs

1. In order to detect stop valves failing to open, operation of the unit is compulsorily performed in cooling for 2-3 minutes during the first test run, even if the remote controller was set to heating operation. In this case, the remote controller will have kept displaying the heating symbol all the time and the unit will switch to heating operation automatically after elapse of that time.
2. In case you cannot operate the unit in test run mode for any unusual reason, refer to "15.5. Failure diagnosis at the moment of first installation" on page 19.
3. In case of a wireless remote controller, execute the run only after having installed the indoor unit decoration panel with infrared receiver first.
4. In case the panels of indoor units are not yet installed to the indoor units, make sure to shut off the power supply after finishing the complete test run.
5. A complete test run surely includes shutting off power after having performed a normal operation stop on the remote controller. Do not stop operation by turning circuit breakers off.

7.10.3 Refrigerant pipe size for maxi split system

The MAXI SPLIT system is an ideal option for open spaces in medium sized premises such as shops and offices, where two, three or four units are required. These can be Cassettes (AB Series) or Ceiling suspended (AC Series) models and can be connected to a single outdoor unit using twin, triple, quadruple manifold. Please refer to the table below to choose suitable manifold and wire controller according to combinations of indoor unit and outdoor unit.

The matching table of MAXI SPLIT series						
Manifold Model	Gas side manifold	Liquid side manifold	Outdoor unit Model	Indoor Unit Model	Number of indoor Units	Wire controller
FQG-2Y100A			1UH105	18000BTU	2	YR-E17 OR YR-E16A
FQG-2Y200A			1UH125 1UH140	24000BTU 28000BTU	2	YR-E17 OR YR-E16A
FQG-3Y100A			1UH105	12000BTU	3	YR-E17 OR YR-E16A
FQG-3Y200A			1UH125 1UH140	18000BTU	3	YR-E17 OR YR-E16A
FQG-4Y200A			1UH125 1UH140	18000BTU	4	YR-E17 OR YR-E16A

MAXI SPLIT SYSTEM UNITS WIRING DIGRAM

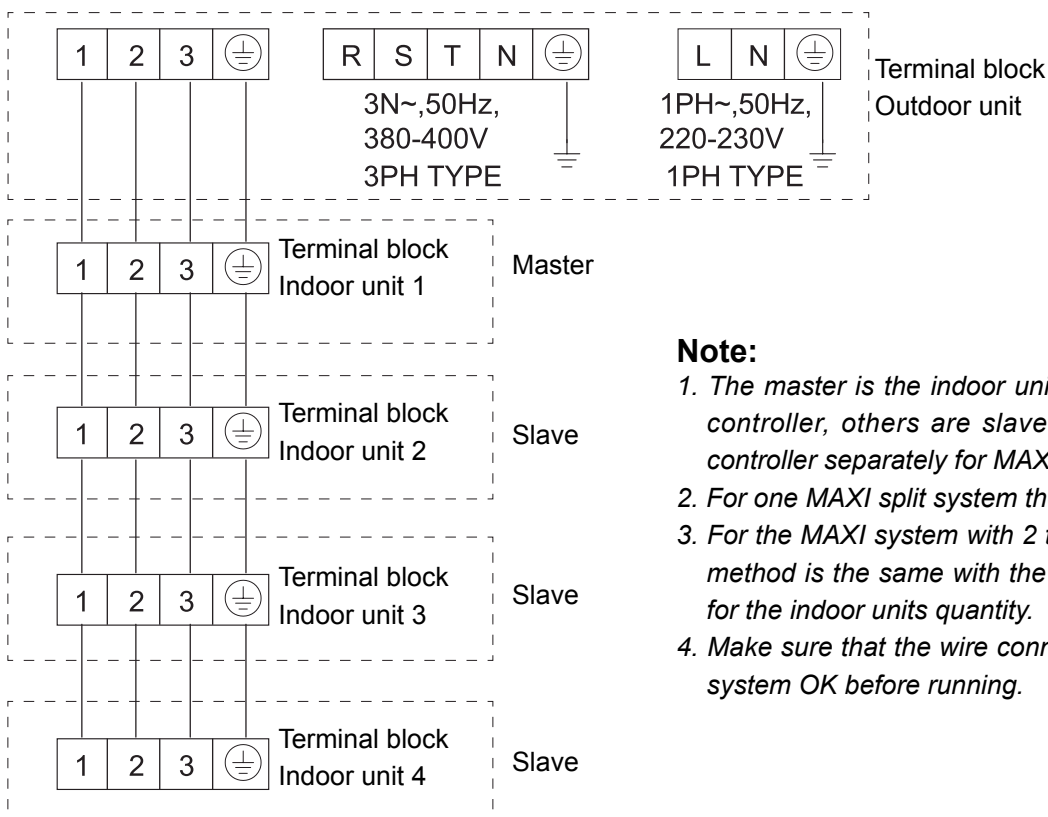

**Note:**

1. The master is the indoor unit which connect to a wired controller, others are slaves, please purchase wired controller separately for MAXI system.
2. For one MAXI split system there is only one master.
3. For the MAXI system with 2 to 3 indoor units, the wiring method is the same with the diagram on the left except for the indoor units quantity.
4. Make sure that the wire connection for all units in MAXI system OK before running.

### 7.10.4 Specification of refrigerant charge for single split and maxi split.

1. It is not necessary to charge additionally when the piping length  $L+P \leq 20\text{m}$ .
2. Please charge refrigerant additionally according to the following table when the piping length  $L+P \geq 20\text{m}$  or need to complete recharge.

Single Split		Twin		Triple		Quadruple	
Charge (g)	$L > 20$	$L \leq 20, L+P > 20$	$L > 20$	$L \leq 20, L+P > 20$	$L > 20$	$L \leq 20, L+P > 20$	$L > 20$
1UH105	$(L-20) * 45$	$(L+P-20) * 30$	$(L-20) * 45 + P * 30$	$(L+P-20) * 30$	$(L-20) * 45 + P * 30$	-	-
1UH125	$(L-20) * 45$	$(L+P-20) * 45$	$(L+P-20) * 45$	$(L+P-20) * 30$	$(L-20) * 45 + P * 30$	$(L+P-20) * 30$	$(L-20) * 45 + P * 30$
1UH140	$(L-20) * 45$	$(L+P-20) * 45$	$(L+P-20) * 45$	$(L+P-20) * 30$	$(L-20) * 45 + P * 30$	$(L+P-20) * 30$	$(L-20) * 45 + P * 30$
P (m)	$P=0$	$P=L1+L2$		$P=L1+L2+L3$		$P=L1+L2+L3+L4$	

Remark:

- a. L is the main pipe length of liquid pipe; P is the sum length of branch liquid pipes.
  - b. The piping length L+P means the sum of the main pipe and branch pipes.
- For MAXI system (Twin, Triple, Quadruple), piping length = L+P L.

For single split system,  $L+P=L$ , because  $P=0$ .

Example 1:

Note:

- (1)  $L=15 < 20$ ;  $L+P=L+L1+L2=15+10+5=30 > 20$
- (2) Refrigerant charging amount =  $(L+P-20) * 30 = 300\text{g}$
- (3) TYPE 18K means capacity 18000Btu/h type

Example 2:

Note:

- (1)  $L=30 > 20$ ;  $P=L1+L2+L3+L4=10+10+5+5=30$
- (2) Refrigerant charging amount =  $(L-20) * 45 + P * 30 = 1350\text{g}$
- (3) TYPE 12K means capacity 12000Btu/h type



When installing MAXI SPLIT Series (1UH105N1ERG/1UH125P1ERG/1UH125P1ERK/1UH140P1ERG/1UH140P1ERK) , Please refer to the table below concerning the pipe lengths, heights and sizes.

MAXI Model	Piping daigram	Total One-way piping ength			Height between outdoor unit and indoor unit		
Twin		L+L1+L2			H		
		1UH105	1UH125	1UH140	1UH105	1UH125	1UH140
		≤60	≤80	≤80	≤20	≤30	≤30
		Difference between branch length			Main piping size		
		L1-L2			liquid side/gas side		
		1UH105	1UH125	1UH140	1UH105	1UH125	1UH140
≤10			φ9.52	φ9.52	φ9.52		
			φ15.88	φ15.88	φ15.88		
Triple		L+L1+L2			H		
		1UH105	1UH125	1UH140	1UH105	1UH125	1UH140
		≤60	≤80	≤80	≤20	≤30	≤30
		Lx-Ly  x,y=1,2,3, x≠y			liquid side/gas side		
		1UH105	1UH125	1UH140	1UH105	1UH125	1UH140
		≤10			φ9.52	φ9.52	φ9.52
			φ15.88	φ15.88	φ15.88		
Quadruple		L+L1+L2+L3+L4			H		
		1UH105	1UH125	1UH140	1UH105	1UH125	1UH140
		/	≤80	≤80	/	≤20	≤30
		Lx-Ly  x,y=1,2,3, x≠y			liquid side/gas side		
		1UH105	1UH125	1UH140	1UH105	1UH125	1UH140
		/	≤10	≤10	/	φ9.52	φ9.52
				φ15.88	φ15.88		
MAXI Model	Piping daigram	Branch piping length			Height between indoors		
Twin		L1 OR L2			H1		
		1UH105	1UH125	1UH140	1UH105	1UH125	1UH140
		≤20			≤0.5		
		Branch piping size					
		liquid side/gas side					
		1UH105	1UH125	1UH140	1UH105	1UH125	1UH140
φ6.35	φ9.52	φ9.52					
φ12.7	φ15.88	φ15.88					
Triple		L1 OR L2 OR L3			H1		
		1UH105	1UH125	1UH140	1UH105	1UH125	1UH140
		≤20			≤0.5		
		liquid side/gas side					
		1UH105	1UH125	1UH140	1UH105	1UH125	1UH140
		φ6.35	φ6.35	φ6.35			
φ9.52	φ12.7	φ12.7					
Quadruple		L1 OR L2 OR L3 OR L4			H1		
		1UH105	1UH125	1UH140	1UH105	1UH125	1UH140
		/	≤20	≤20	/	≤0.5	≤0.5
		liquid side/gas side					
		1UH105	1UH125	1UH140	1UH105	1UH125	1UH140
		/	φ6.35	φ6.35			
				φ9.52	φ9.52		

**Part 5 Electric Control and Troubleshooting**

1. Indoor unit PCB photo .....	101
2. Indoor unit dip switch setting .....	102
3. Outdoor unit PCB photo .....	104
4. Failure code.....	106
5. Instructions of parameters & error code checking .....	120
6. Function.....	129
7. Controller.....	144

1. Indoor unit

1.1 ABH071K1ERG ABH090K1ERG ABH105K1ERG ABH125K1ERG ABH140K1ERG  
PCB photo 0151800208

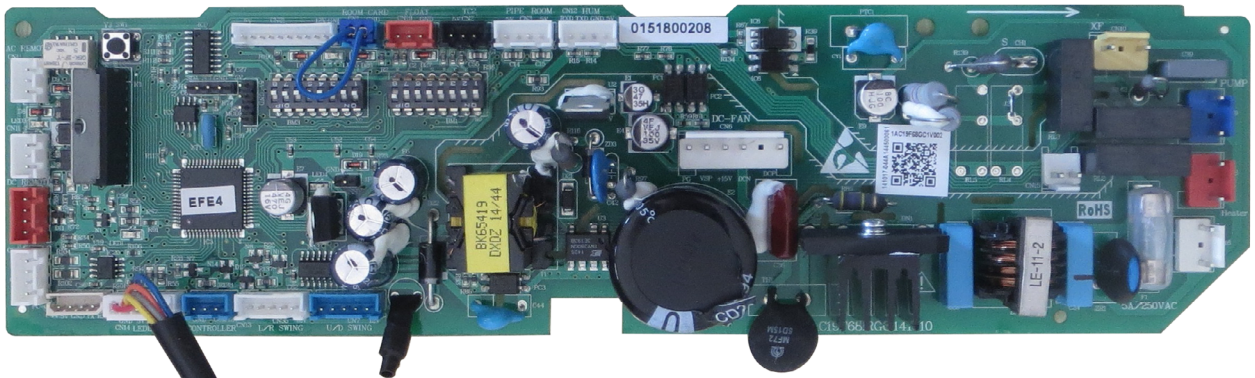

1.2 ADH071M1ERG ADH090M1ERG  
PCB CODE 0151800175B

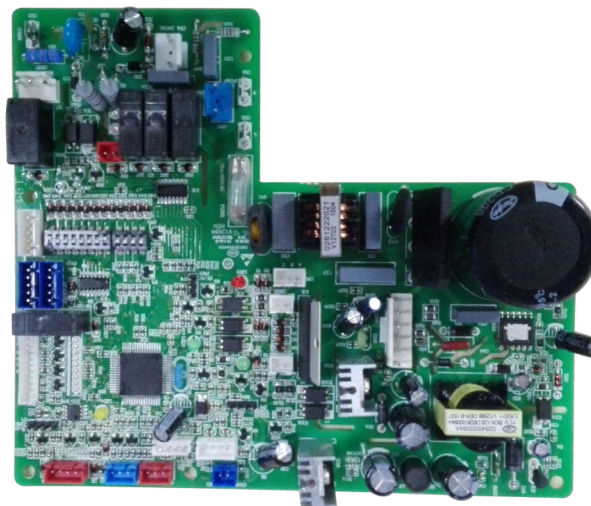

1.3 ADH105M1ERG AD125M1ERG AD140M1ERG  
PCB CODE 0151800106E

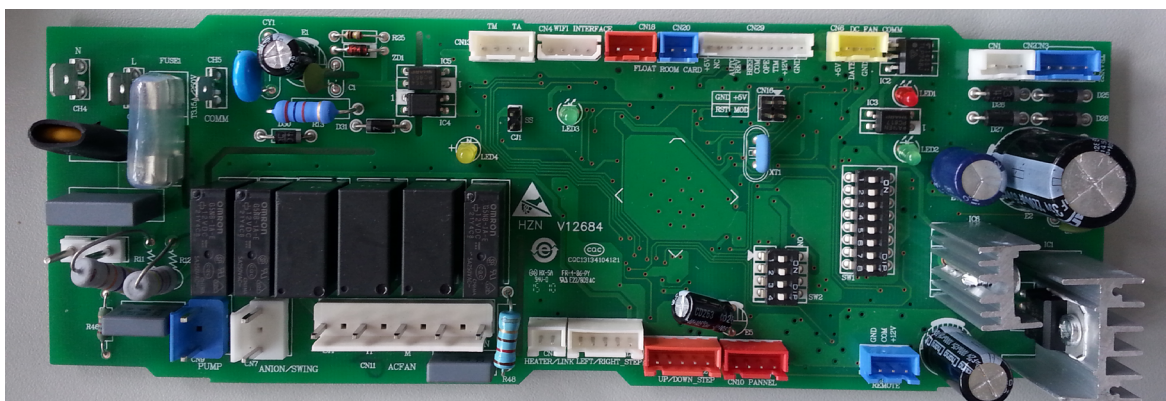

## 2. Indoor unit dip switch setting

Settings status when out of factory

ABH071K1ERG ABH090K1ERG ABH105K1ERG ABH125K1ERG ABH140K1ERG :

PCB code 0151800208

BM1 (1-ON, 0-OFF)								
Capacity (SW1-1→SW1-3)			Room card SW1-4	Running mode SW1-5	Unit Type			Description
SW1-1	SW1-2	SW1-3			SW1-6	SW1-7	SW1-8	
1	1	0	---	---	---	---	---	Capacity: 7.1kW
0	0	1	---	---	---	---	---	Capacity: 9.0kW
1	0	1	---	---	---	---	---	Capacity: 10.5kW
0	1	1	---	---	---	---	---	Capacity: 12.5kW
1	1	1	---	---	---	---	---	Capacity: 14.0kW
---	---	---	0	---	---	---	---	Room card invalid
---	---	---	1	---	---	---	---	Room card valid
---	---	---	---	0	---	---	---	Heat pump
---	---	---	---	1	---	---	---	Cooling only
---	---	---	---	---	0	0	1	High performance cassette

### Wired controller communication address

BM3-5	BM3-6	BM3-7	BM3-8	Indoor unit Address (Indoor unit address for one wired controller control more than one unit)
OFF	OFF	OFF	OFF	0 (master)
OFF	OFF	OFF	ON	1(slave)
OFF	OFF	ON	OFF	2(slave)
OFF	OFF	ON	ON	3(slave)
OFF	ON	OFF	OFF	4(slave)
OFF	ON	OFF	ON	5(slave)
OFF	ON	ON	OFF	6(slave)
OFF	ON	ON	ON	7(slave)
ON	OFF	OFF	OFF	8(slave)
ON	OFF	OFF	ON	9(slave)
ON	OFF	ON	OFF	10(slave)
ON	OFF	ON	ON	11(slave)
ON	ON	OFF	OFF	12(slave)
ON	ON	OFF	ON	13(slave)
ON	ON	ON	OFF	14(slave)
ON	ON	ON	ON	15(slave)

ADH071M1ERG ADH090M1ERG  
PCB code 0151800175B

BM1 (1-ON, 0-OFF)								
Capacity (SW1-1→SW1-3)			ESP selection		Room card SW1-6	Unit Type		Description
SW1-1	SW1-2	SW1-3	SW1-4	SW1-5		SW1-7	SW1-8	
ON	OFF	ON	---	---	---	---	---	ADH071M1ERG
OFF	ON	ON	---	---	---	---	---	ADH090M1ERG
---	---	---	OFF	OFF	---	---	---	1st level(10Pa)(default)
---	---	---	OFF	ON	---	---	---	2nd level(30Pa)
---	---	---	ON	OFF	---	---	---	3rd level(50Pa)
---	---	---	ON	ON	---	---	---	4th level(70Pa)
---	---	---	---	---	OFF	---	---	Room card unavailable
---	---	---	---	---	ON	---	---	Room card available
---	---	---	---	---		ON	OFF	Medium ESP DUCT

**Wired controller communication address**

SW2-1	SW2-2	SW2-3	SW2-4	Indoor unit Address (Indoor unit address for one wired controller control more than one unit)
OFF	OFF	OFF	OFF	0 (master)
OFF	OFF	OFF	ON	1(slave)
OFF	OFF	ON	OFF	2(slave)
OFF	OFF	ON	ON	3(slave)
OFF	ON	OFF	OFF	4(slave)
OFF	ON	OFF	ON	5(slave)
OFF	ON	ON	OFF	6(slave)
OFF	ON	ON	ON	7(slave)
ON	OFF	OFF	OFF	8(slave)
ON	OFF	OFF	ON	9(slave)
ON	OFF	ON	OFF	10(slave)
ON	OFF	ON	ON	11(slave)
ON	ON	OFF	OFF	12(slave)
ON	ON	OFF	ON	13(slave)
ON	ON	ON	OFF	14(slave)
ON	ON	ON	ON	15(slave)

ADH105M1ERG ADH125M1ERG ADH140M1ERG PCB code 0151800106E

BM1 (1-ON, 0-OFF)								
Capacity (SW1-1→SW1-3)			Room card SW1-4	Running mode SW1-5	Unit Type			Description
SW1-1	SW1-2	SW1-3			SW1-7	SW1-7	SW1-8	
ON	OFF	ON	---	---	---	---	---	ADH105M1ERG
OFF	ON	ON	---	---	---	---	---	ADH125M1ERG
ON	ON	ON	---	---	---	---	---	ADH140M1ERG
---	---	---	ON	---	---	---	---	Room card valid
---	---	---	OFF	---	---	---	---	Room card invalid(default)
---	---	---	---	ON	---	---	---	Cool only
---	---	---	---	OFF	---	---	---	Cool and heat(default)
---	---	---	---	---	OFF	ON	OFF	Medium ESP DUCT
---	---	---	---	---	ON	ON	OFF	High ESP DUCT

**Wired controller communication address**

SW3-1	SW3-2	SW3-3	SW3-4	Indoor unit Address (Indoor unit address for one wired controller control more than one unit)
OFF	OFF	OFF	OFF	0 (master)
OFF	OFF	OFF	ON	1(slave)
OFF	OFF	ON	OFF	2(slave)
OFF	OFF	ON	ON	3(slave)
OFF	ON	OFF	OFF	4(slave)
OFF	ON	OFF	ON	5(slave)
OFF	ON	ON	OFF	6(slave)
OFF	ON	ON	ON	7(slave)
ON	OFF	OFF	OFF	8(slave)
ON	OFF	OFF	ON	9(slave)
ON	OFF	ON	OFF	10(slave)
ON	OFF	ON	ON	11(slave)
ON	ON	OFF	OFF	12(slave)
ON	ON	OFF	ON	13(slave)
ON	ON	ON	OFF	14(slave)
ON	ON	ON	ON	15(slave)



3. Outdoor unit PCB photo

PCB: 0151800054B

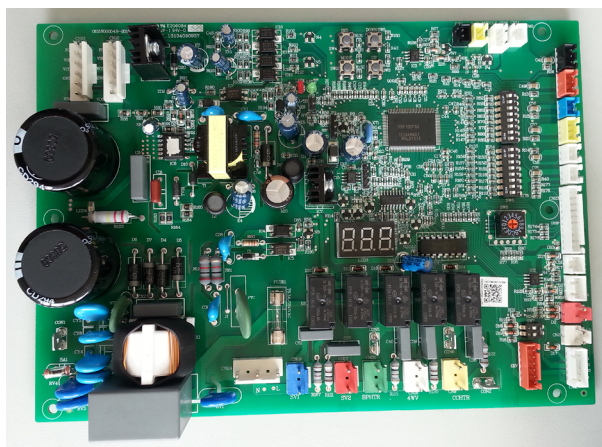

Power module: 0150401826

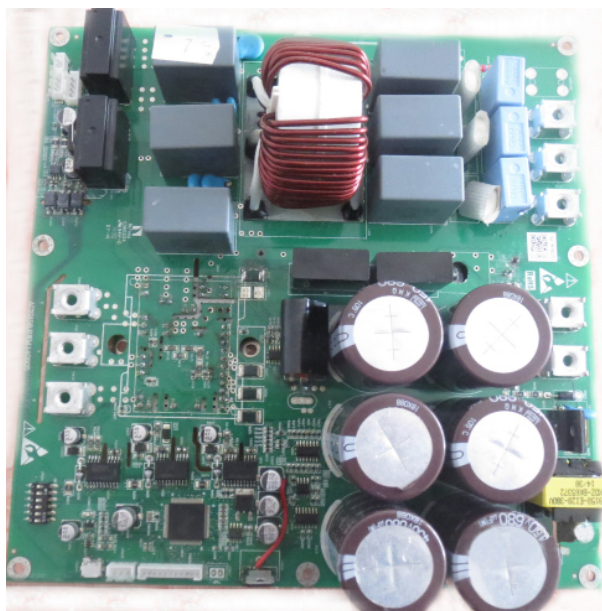

Power module: 0150401824



## Outdoor unit dip switch setting

SW8: Dip switch setting

SW1-1	SW1-2	SW1-3	SW1-4	SW1-5	SW1-6	SW1-7	SW1-8	Description
OFF	----	----	----	----	----	----	----	Manually forced operation invalid(default)
ON	----	----	----	----	----	----	----	Manually forced operation valid
----	OFF	----	----	----	----	----	----	Manually forced heating(default)
----	ON	----	----	----	----	----	----	Manually forced cooling
----	----	OFF	----	----	----	----	----	Normal standby cost(default)
----	----	ON	----	----	----	----	----	Low stand by power cost
----	----	----	OFF	----	----	----	----	Water heater or heating only
----	----	----	ON	----	----	----	----	Unit as air conditioner (default)
----	----	----	----	OFF	----	----	----	Central control(default)
----	----	----	----	ON	----	----	----	BMS
----	----	----	----	----	OFF	----	----	Refrigerant R410A(default)
----	----	----	----	----	ON	----	----	Refrigerant R32
----	----	----	----	----	----	OFF	----	Defrost automatic(default)
----	----	----	----	----	----	ON	----	Defrost by time
----	----	----	----	----	----	----	OFF	Not for base station
----	----	----	----	----	----	----	ON	Base station application(default)

SW6 (1-ON, 0-OFF)								Unit address for central control
SW6-1	SW6-2	SW6-3	SW6-4	SW6-5	SW6-6	SW6-7	SW6-8	
0	0	0	0	0	0	0	0	0
0	0	0	0	0	0	0	1	1
0	0	0	0	0	0	1	0	2
0	0	0	0	0	0	1	1	3
0	0	0	0	0	1	0	0	4
0	0	0	0	0	1	0	1	5
0	0	0	0	0	1	1	0	6
0	0	0	0	0	1	1	1	7
----	----	----	----	----	----	----	----	----
1	1	1	1	1	1	1	1	255

SW7 (1-ON, 0-OFF)		Defination
SW7-1	SW7-2	
0	0	DERD test selection 0
0	1	DERD test selection 1
1	0	DERD test selection 2
1	1	DERD non-test selection

SW8	Defination
0	1UH071N1ERG
1	1UH090N1ERG
2	1UH105N1ERG
4	1UH125P1ERG
5	1UH140P1ERG
8	1UH125P1ERK
9	1UH140P1ERK



## 4. Failure code

### 4.1 Failure code indoor unit

ABH071H1ERG ABH90H1ERG ABH105H1ERG ABH125K1ERG ABH140K1ERG

LED flash times of indoor PCB		LR.Receiver digital display	Contents of malfunction	Possible reasons
LED4	LED1			
0	1	01	Malfunction of indoor unit ambient temperature sensor	Sensor disconnected, or broken, or at wrong position, or short circuit
0	2	02	Malfunction of indoor unit piping temperature sensor	Sensor disconnected, or broken, or at wrong position, or short circuit
0	4	04	EEPROM error of indoor PCB	EEPROM chip disconnected, or the wires be disconnected or wrong address setting of indoor unit or faulty power supply or faulty PCB or slave unit malfunction in MAXI system
0	7	07	Abnormal communication between indoor and outdoor units	Wrong connection, or the wires be disconnected or wrong address setting of indoor unit or faulty power supply or faulty PCB or slave unit malfunction in MAXI system
0	8	08	Abnormal communication between wired controller (or I.R. RECEIVER) and indoor unit	Wrong connection or wired controller broken, or PCB faulty
0	12	0C	Malfunction of drain system	Pump motor disconnected or at wrong position, or the float switch, disconnected, or at wrong position, or the short circuit bridge disconnected
0	13	0D	Zero cross signal wrong	Zero cross signal detected wrong
0	14	0E	Indoor unit DC fan motor abnormal	DC Fan motor disconnected or DC Fan broken or circuit broken

#### Note:

1. The outdoor failure can also be indicated by the indoor unit, the checking method as follows: If the outdoor error code is M (DECIMAL), the indoor unit's I.R. receiver display will show the after converted hexadecimal code of "M+20" (DECIMAL), for example, if the outdoor error code is 2, the indoor unit I.R. receiver display will flash the error code 16 (2→2+20=22→change decimal 22 to hexadecimal code, get 16)
2. LED4 is a red one on the indoor PCB, LED1 is a yellow one.
3. To get much more details about the outdoor unit failure, please refer to the outdoor unit trouble shooting list.

Smart power cassette units error code correspondence			
Cassette panel I.R. receiver digital display (error code keep flashing)	Correspond to outdoor unit error code	Contents of malfunction	Remark
01	/	Malfunction of indoor unit ambient temperature sensor	Malfunction of indoor unit. Refer to indoor unit trouble shooting list to get more details
02	/	Malfunction of indoor unit piping temperature sensor	
04	/	EEPROM wrong of indoor PCB	
07	/	Abnormal communication between indoor and outdoor units	
08	/	Abnormal communication between wired controller(or I.R .RECEIVER) and indoor unit	
0C	/	Malfunction of drain system (float switch open circuit)	
0D	/	indoor unit zero cross signal been detected wrong	
0E	/	Indoor unit DC fan motor abnormal	
15	1	outdoor main control PCB EEPROM malfunction	Malfunction of outdoor unit. Refer to outdoor unit trouble shooting list to get more details
16	2	PIM(power intelligent module)hardware overcurrent	
17	3	Compressor over current during deceleration	
18	4	Communication abnormal between control board and compressor driver module	
19	5	Compressor overcurrent detected by control board	
1A	6	DC voltage or AC voltage high	
1B	7	Compressor current sampling circuit fault	
1C	8	Discharge temperature too high protection	
1D	9	DC fan motor fault	
1E	10	Outdoor defrosting temp. sensor Te abnormal	
1F	11	Suction temp.sensor Ts abnormal	
20	12	Outdoor ambient temp. sensor Ta abnormal	
21	13	Discharging temp. sensor Td abnormal	
22	14	PFC circuit loop high voltage	
23	15	Communication abnormal between indoor unit and outdoor unit	
24	16	Lack of refrigerant or discharging pipe blocked	
25	17	4-way valve converse abnormal	
26	18	Compressor motor desynchronizing	

Smart power cassette units error code correspondence			
Cassette panel I.R. receiver digital display (error code keep flashing)	Correspond to outdoor unit error code	Contents of malfunction	Remark
28	20	Indoor pipe temperature too high protection	Malfunction of outdoor unit. Refer to outdoor unit trouble shooting list to get more details
2A	22	PFC circuit loop overcurrent	
2B	23	Temperature too high for compressor driver module	
2C	24	Compressor start failure	
2D	25	Input overcurrent of the drive module	
2E	26	Lack phase of the drive module power supply	
2F	27	Input current sampling circuit fault	
30	28	No wiring of the compressor	
39	37	Compressor overcurrent detected by compressor driver module	
3A	38	Drive module's ambient temp. sensor abnormal	
3B	39	Mid-condenser temp. sensor TC abnormal	
3E	42	High pressure switch abnormal(open circuit)	
3F	43	Low pressure switch abnormal(open circuit)	
40	44	Outdoor condenser temperature TC too high protection	
41	45	System low pressure protection	

**Note:**

The outdoor failure can also be indicated by the indoor unit, the checkin gmethod as followings: If the outdoor error code is M(DECIMAL), the indoor unit's I.R. receiver display will show the after convert3erd hexadecimal code of "M+20"(DECIMAL)

For example, if the outdoor error code is 2, the indoor unit I.R. receiver display will flash the error code 16(2→2+20=22→change decmal 22 to hexadecimal code, get 16)

## ADH071M1ERG ADH090M1ERG ADH105M1ERG ADH125M1ERG ADH140M1ERG

LED flash times of indoor PCB		Wired controller display	Contents of	Possible reasons
LED4	LED3			
0	1	01	Malfunction of indoor unit ambient temperature sensor	Sensor disconnected, or broken, or at wrong position, or short circuit
0	2	02	Malfunction of indoor unit piping temperature sensor	Sensor disconnected, or broken, or at wrong position, or short circuit
0	4	04	EEPROM wrong of indoor PCB	EEPROM chip disconnected or broken or wrong program-med, or PCB broken
0	7	07	Abnormal communication between indoor and outdoor units	Wrong connection, or the wires be disconnected or wrong address setting of indoor unit or faulty power supply or PCB hardware malfunction
0	8	08	Abnormal communication between wired controller and indoor unit	Wrong connection or wired controller broken, or PCB hardware malfunction
0	12	0C	Malfunction of drain system	Pump motor disconnected or at wrong position, or the float switch, disconnected, or at wrong position, or the short circuit bridge disconnected
0	13	0D	Zero cross signal wrong	Zero cross signal detected wrong
0	14	0E	Abnormal communication between main control PCB & fan motor drive	Communication wire disconnected or wrong connected or PCB hardware malfunction
0	15	0F	Fan motor overcurrent	Fan motor current too high
0	17	11	DC voltage high or low	DC voltage of the fan motor driver too high or too low
0	18	12	F.M.D temperature high	Fan motor driver over 95°C
0	19	13	Fan motor out of step	Wrong rotor location detected
M (≥1)	N (≥0)	/	Error of the outdoor unit	See note 1,2

**Note:**

1. The outdoor failure can also be indicated by the indoor unit, the checking method as follows: outdoor unit error code = (M\*10+N)-20. LED4 flash M times and LED3 flash N times.
2. LED4 is a yellow one on the indoor main control PCB, LED3 is a green one.
3. To get much more details about the outdoor unit failure, please refer to the outdoor unit trouble shooting list.

## 4.2 1UH090&amp;105&amp;125&amp;140N (P) 1ERG (K)

OUTDOOR UNIT TROUBLE SHOOTING			
Error code	Malfunction Description	Diagnosis and Analysis.	Remark
1	EEPROM malfunction	EEPROM chip damaged or data wrong or related circuit damaged.	Non-resumable
2	PIM (power intelligent module) hardware over current	Input over current occurred been detected by PIM's hardware.	Resumable
3	Compressor over current during deceleration	Over current occurred during compressor deceleration period.	Non-resumable
4	Communication abnormal between control board and compressor driver module	Control board can not communicating with compressor driver module over 4 minutes	Resumable
5	Compressor overcurrent detected by control board	Compressor over current been detected by control board	Non-resumable
6	DC voltage or AC voltage high	AC power supply of the driver module get voltage over 280VAC or driver module get high DC-BUS voltage over 390VDC.	Resumable
7	Compressor current sampling circuit fault	The driver module's Compressor current sampling circuit damaged.	Non-resumable
8	Discharge temperature too high protection	Compressor discharge temperature over 115°C, error clear within 3 minutes if temperature goes down and lower than 115°C. Error status lock if it occurs 3 times in 1 hour.	Non-resumable
9	DC fan motor fault	DC fan motor damage or not connected or related circuit broken. Error status confirm and lock if occurs 3 times within 30 minutes.	Non-resumable
10	Outdoor defrosting temp. sensor Te abnormal	Sensor temperature been detected below -55°C or higher than 90°C or been detected as short circuit or open circuit..	Resumable
11	Suction temp.sensor Ts abnormal		
12	Outdoor ambient temp. sensor Ta abnormal	Sensor temperature been detected below -40°C or higher than 90°C or been detected short circuit or open circuit.	Resumable
13	Discharging temp. sensor Td abnormal	Sensor temperature been detected below -40°C or higher than 150°C or been detected short circuit or open circuit .	Resumable
14	PFC circuit loop high voltage	Overvoltage been detected in driver module's power factor correction circuit loop.	Resumable
15	Communication abnormal between indoor unit and outdoor unit	Outdoor unit control board can not communicating with indoor unit control board over 4 minutes.	Resumable
16	Lack of refrigerant or discharging pipe blocked	Discharge & suction temperature Td-Ts≥80°C after compressor started 10 minutes.Error status lock if it occurs 3 times in 1 hour.	Non-resumable
17	4-way vavle converse abnormal	Indoor pipe & indoor ambient temperature Tm-Tai≥5°C after compress- or started 10 minutes. Error status lock if it occurs 3 times in 1 hour.	Non-resumable
18	Compressor motor desynchronizing	Rotor desynchronizing occurred, caused by overload or load sharply fluctuating or compressor current sensor circuit abnormal or one of the inverter's gate drive signal missing.	Non-resumable

Error code	Malfunction Description	Diagnosis and Analysis	Remark
19	DC voltage or AC voltage low	AC power supply of the driver module get voltage lower than 155VAC or driver module get high DC-BUS voltage lower than 180VDC.	Resumable
20	Indoor pipe temperature too high protection	Indoor pipe temperature $T_m$ over $63^{\circ}\text{C}$ , error clear within 3 minutes if temperature goes down and lower than $52^{\circ}\text{C}$ .	Resumable
22	PFC circuit loop overcurrent	Overcurrent been detected in power factor correction circuit loop.	Resumable
23	Temperature too high for compressor driver module	Compressor driver module's PIM temperature over $90^{\circ}\text{C}$ , Error stat-us lock if it occurs 3 times in 1 hour.	Non-resumable
24	Compressor start failure	Compressor start failure been detected by driver driver module.	Non-resumable
25	Input overcurrent of the drive module	Input current of the compressor drive module higher than 32A (double fan model) or 27A (single fan) , Lock if it occurs 3 times in 1 hour.	Non-resumable
26	Lack phase of the drive module	Lack phase of the drive module's power supply.(three phase type)	Non-resumable
27	Input current sampling circuit fault	The driver module's input current sampling circuit damaged.	Resumable
28	No wiring of the compressor	No wiring between compressor and it's driver module.	Non-resumable
37	Compressor overcurrent detected by compressor driver module	Compressor phase U or V or W current over 27A (single phase model) or 19.1A (single phase model) occured during non-rated period.	Resumable
38	Drive module's ambient temp. sensor abnormal	The temperature detected is not within the range of $-25^{\circ}\text{C}$ to $150^{\circ}\text{C}$ .	Resumable
39	Mid-condenser temp. sensor TC abnormal	The temperature detected is not within the range of $-55^{\circ}\text{C}$ to $90^{\circ}\text{C}$ .	Resumable
42	High pressure switch abnormal	After compressor running for 3 minutes, switch been detected open circuit for 30seconds, Error lock if it occurs 3 times in 1 hour.	Non-resumable
43	Low pressure switch abnormal	After compressor running for 3 minutes, switch been detected uncon-nected for 60seconds or unconnected for 30seconds at standby.	Non-resumable
44	Outdoor condenser temperatureTC too high protection	The maximum temperature value of $T_c$ and $T_e$ is over $65^{\circ}\text{C}$ , Error lock if it occurs 3 times in 30 minutes.	Non-resumable
45	System low pressure protection	The minimum temperature value of indoor pipe $T_m$ and outdoor $T_s$ is lower than $-45^{\circ}\text{C}$ at cooling mode or minimum temperature value of outdoor $T_c$ and outdoor $T_e$ is lower than $-45^{\circ}\text{C}$ .	Non-resumable

**Note:**

1. The outdoor control board's LED3 indicates the outdoor error code. for example, the error code 12, LED3 will display 12 and keep flashing.
2. NO-resumable means error will not clear unless: a. clean out the fault factor b. Cut the power supply off and reoffer again after point a achieved.
3. The indoor unit can also indictes the outdoor malfunction code too. Please refer to indoor unit manul to get the method.

### 4.3 Power module error code checking for 1UH071/090/105N1ERG

#### 1. Drive Status Indication

LED	LED display Description	LED position
LED 601 (GREEN )	Flashing (on 1s, Off 1s) : Drive is operating normally Flashing (on 0.25s off 0.25s, flashes n times and then off 2s as a period) : Module board failure	Module board

#### 2. Protection function

Protection style:

Protection style	Explanation	LED	LED display Description	ERROR Recovery
Shutdown protection	When the voltage, current, temperature, etc. to meet the shutdown protection Level, drive immediately stop output, and LED display fault information, and upload the error symbol	LED 601 (GREEN)	Flashes n times, off 2s; (n is the error code)	Needs to keep the error information 2min, then ERROR Recovery

#### 3. Shutdown protection error code

Error code	Hardware/software protection	Error detail	Protection Level	Error symbol
1	Software	PIM module overheat	105°C and continued 5s	01H
2	Software	PIM temperature sampling failure	/	18H
3	Software	Overcurrent protection when limit frequency	/	02H
4	Hardware	Hardware protection PIM_INT	PIM_INT	04H
6	Software	DC under voltage	180V	05H
7	Software	DC high voltage	390V	06H
8	Software	Communication error	/	07H
9	Software	Output lack of phase	/	16H
10	Software	Preset	/	/
11	Software	U phase overcurrent	40A	0AH
12	Software	Compressor is out of step	/	0EH
13	Software	V phase overcurrent	40A	0CH
14	software	W phase overcurrent	40A	0DH
15	Software	Compressor startup failure	/	0FH
16	Software	Phase current sampling failure	/	09H
19	Software	AC input under voltage	155V	11H
20	Software	AC input overvoltage	280V	12H
21	Software	AC input overcurrent	35A	13H
22	Software	Input current sampling failure	/	08H
23		Preset		
24		Preset		
25		Preset		
27		Preset		
30		Preset		

Appendix A Protection function logic and protection level

## PIM temperature protection

Temperature more than 105°C, and continue 5 seconds, then drive shutdown protection.

## Compressor startup failure protection

The drive will attempt to start the compressor 5 times, at intervals of 15 seconds. When the drive is making five times the driving signal cannot normally drive the compressor, for the protection of the relevant parts, compressor immediately shut down, and the drive will have the compressor drive failure protection.

## Limit frequency/shutdown protection

Compressor current protection:

Error protection	Protection condition	Error symbol
Shutdown protection	Compressor phase current > compressor phase current shutdown protection current (RMS) , the compressor immediately stop, drive into the limited-frequency overcurrent protection.	
Limit frequency protection	Compressor phase current > compressor Phase current Limit frequency protection current (RMS) , the compressor will decrease the frequency by the 2Hz/sec rate.	Limit frequency protection
	After compressor decrease the frequency, compressor phase current limit frequency protection current (RMS) ≥ compressor phase current > compressor phase current protection recovery current (RMS) , forbid increase the compressor frequency.	Forbid increase the compressor frequency
Protection recovery	Compressor phase current ≤ Compressor phase current protection recovery current (RMS) , cancel the compressor limit frequency protection and normally operation	

## Drive input current protection:

Error protection	Protection condition	Error symbol
Shutdown protection	Compressor phase current > compressor phase current shutdown protection current (RMS) , the compressor immediately stop, drive into the limited frequency overcurrent protection.	
Limit frequency protection	Compressor phase current > compressor Phase current limit frequency protection current (RMS) , the compressor will decrease the frequency by the 2Hz/sec rate.	Limit frequency protection
	After compressor decrease the frequency, compressor phase current limit frequency protection current (RMS) ≥ compressor phase current > compressor phase current protection recovery current (RMS) , forbid increase the compressor frequency.	Forbid increase the compressor frequency
Protection recovery	Compressor phase current ≤ Compressor phase current protection recovery current (RMS) , cancel the compressor limit frequency protection and normally operation.	



## DC bus over/under voltage protection

Bus voltage>overvoltage shutdown value, the compressor stop, then drive into the bus overvoltage protection.

Bus voltage<overvoltage recovery value, cancel the bus overvoltage protection.

Bus voltage<under voltage shutdown value, the compressor stop, then drive into the bus under voltage protection.

Bus voltage>voltage recovery value, cancel the bus under voltage protection.

## AC input over/under voltage protection

Drive come with AC voltage detection, avoid the input voltage is too low, cause the input current is too high, damage the device.

Input voltage<under voltage shutdown value, the compressor stop, then drive into the input under voltage protection.

Input voltage>voltage recovery value, cancel the under voltage protection.

Drive come with AC voltage detection, avoid the input voltage is too high, damage the device.

Input voltage>overvoltage shutdown value, the compressor stop, then drive into the input overvoltage protection.

Input voltage<overvoltage recovery value, cancel input overvoltage protection.

## Communication error

Drive priority detect the model code after power on .the 30s after power on is the time for the model code setting.

And need to complete the model code setting within this 30s, if setting completely, are not allowed to change.

Compressor type	Model code
TNB220FFEMC	0x02DC
TNB306FFEMC	0x02DD

If the model code is not within the model range or the 30s not receive correct communication data, that the communication failure, execute communications shutdown protection, while communication returns the corresponding error code.

After the communication failure, if the receiver again to correct data and models within the model code range, then cancel the error

Note: For debug mode, when the model code is not within the range of models, sentenced to communication failure; when the model code within the model range, then cancel the error

## PFC switch value

When PFC sampling current>PFC open switch current and the DC bus average voltage<PFC open switch voltage, then opening PFC;

When PFC sampling current<PFC off switch current, off PFC.

## Protection value

Compressor type TNB220FFEMC:

No.	Error description	Device protection value
1	Compressor phase current Limit frequency protection shutdown current value (RMS)	18A
2	Compressor phase current Limit frequency protection decrease frequency current value (RMS)	13A
3	Compressor phase current Limit frequency protection recovery current value (RMS)	10A
4	PIMTemperature shutdown protection	105°C
5	Drive input current limit frequency protection shutdown current value (RMS)	23A
6	Drive input current limit frequency protection decrease frequency current value (RMS)	18A
7	Drive input current limit frequency protection recovery current value (RMS)	13A
8	AC input overvoltage shutdown value	280V
9	AC input overvoltage recovery value	265V
10	AC input under voltage shutdown value	155V
11	AC input under voltage recovery value	185V
12	DC bus overvoltage shutdown value	390V
13	DC bus overvoltage recovery value	380V

No.	Error description	Device protection value
14	DC bus under voltage shutdown value	180V
15	DC bus under voltage recovery value	200V
16	Communication shutdown protection time	30S
17	PFC open switch current (RMS)	8A
18	PFC open switch voltage	360V
19	PFC off switch current (RMS)	5A

Compressor type TNB306FFEMC:

No.	Error description	Device protection value
1	Compressor phase current Limit frequency protection shutdown current value (RMS)	23A
2	Compressor phase current Limit frequency protection decrease frequency current value (RMS)	18A
3	Compressor phase current Limit frequency protection recovery current value (RMS)	14A

#### 4.4 Power module error code checking for 1UH125/140P1ERG

##### 1. Explanation of LED

LED Model	Explanation of LED display	Position of Led
LED 601 (Green)	Flashing (on,1s, off,1s) : driver works normally. Flashing (on,0.25s, off, 0.25s, flash several times, then off for 2 seconds ) : power module failure.	Power module

##### 2. Protection function

Category of protection:

Category	Explanation	LED	LED display Description	ERROR Recovery
Shutdown protection	When the voltage, current, temperature, etc. to meet the shutdown protection Level, drive immediately stop output, and LED display fault information, and upload the error symbol	LED 601 (GREEN)	Flashes n times, off 2s; (n is the error code)	Needs to keep the error information 2min, then ERROR Recovery

##### 3. Protection error lists

Error code	Hardware/software protection	Error detail	Protection Level	Error symbol
1	Software	PIM module overheat	105°C and continued 5s	01H
2	Software	PIM temperature sampling failure	/	18H
3	Software	Overcurrent protection when limit frequency	/	02H
4	Hardware	Hardware protection PIM_INT	PIM_INT	04H
6	Software	DC under voltage	180V	05H
7	Software	DC high voltage	390V	06H
8	Software	Communication error	/	07H
9	Software	Output lack of Phase	/	16H
10	Software	Reserved	/	/
11	Software	U phase overcurrent	40A	0AH
12	Software	Compressor is out of step	/	0EH
13	Software	V phase overcurrent	40A	0CH
14	software	W phase overcurrent	40A	0DH
15	Software	Compressor startup failure	/	0FH
16	Software	Phase current sampling failure	/	09H
19	Software	AC input under voltage	155V	11H
20	Software	AC input overvoltage	280V	12H
21	Software	AC input overcurrent	35A	13H
22	Software	Input current sampling failure	/	08H
23		Preset		
24		Preset		
25		Preset		
27		Preset		
30		Preset		
32	Software	PFC overcurrent of	75A	14H
34	Software	PFC high voltage	430V	15H

Appendix A Protection function logic and protection level

## PIM temperature protection

Temperature more than 105°C, and continue 5 seconds, then drive shutdown protection.

## Compressor startup failure protection

The drive will attempt to start the compressor 5 times, at intervals of 15 seconds. When the drive is making five times the driving signal cannot normally drive the compressor, for the protection of the relevant parts, compressor immediately shut down, and the drive will have the compressor drive failure protection.

## Limit frequency/shutdown protection

Compressor current protection:

Error protection	Protection condition	Error symbol
Shutdown protection	Compressor phase current > compressor phase current shutdown protection current (RMS) , the compressor immediately stop, drive into the limited frequency overcurrent protection.	
Limit frequency protection	Compressor phase current > compressor Phase current limit frequency protection current (RMS) , the compressor will decrease the frequency by the 2Hz/sec rate.	Limit frequency protection
	After compressor decrease the frequency, compressor phase current limit frequency protection current (RMS) ≥ compressor phase current > compressor phase current protection recovery current (RMS) , forbid increase the compressor frequency.	Forbid increase the compressor frequency
Protection recovery	Compressor phase current ≤ Compressor phase current protection recovery current (RMS) , cancel the compressor limit frequency protection and normally operation.	

## Input current protection of driver:

Error protection	Protection condition	Error symbol
Shutdown protection	Compressor phase current > compressor phase current shutdown protection current (RMS) , the compressor immediately stop, drive into the limited frequency overcurrent protection.	
Limit frequency protection	Compressor phase current > compressor Phase current limit frequency protection current (RMS) , the compressor will decrease the frequency by the 2Hz/sec rate.	Limit frequency protection
	After compressor decrease the frequency, compressor phase current limit frequency protection current (RMS) ≥ compressor phase current > compressor phase current protection recovery current (RMS) , forbid increase the compressor frequency.	forbid increase the compressor frequency
Protection recovery	Compressor phase current ≤ Compressor phase current protection recovery current (RMS) , cancel the compressor limit frequency protection and normally operation	

DC bus over/under voltage protection

Bus voltage > overvoltage shutdown value, the compressor stop, then drive into the bus overvoltage protection.

Bus voltage < overvoltage recovery value, cancel the bus overvoltage protection.

Bus voltage < under voltage shutdown value, the compressor stop, then drive into the bus under voltage protection.

Bus voltage > voltage recovery value, cancel the bus under voltage protection.

AC input over/under voltage protection

Drive come with AC voltage detection, avoid the input voltage is too low, cause the input current is too high, damage the device.

Input voltage < under voltage shutdown value, the compressor stop, then drive into the input under voltage protection.

Input voltage > voltage recovery value, cancel the under voltage protection.

Drive come with AC voltage detection, avoid the input voltage is too high, damage the device.

Input voltage > overvoltage shutdown value, the compressor stop, then drive into the input overvoltage protection.

Input voltage < overvoltage recovery value, cancel input overvoltage protection.

Communication error

Drive priority detect the model code after power on .the 30s after power on is the time for the model code setting.

And need to complete the model code setting within this 30s, if setting completely, are not allowed to change.

Compressor type	Model code
MNB42FDAMC	0x03DE

If model code is out of model range or no right communication data is received within 30s, communication failure is confirmed, execute stop protection under communication failure, in the meanwhile, relevant error code is sent back.

When communication is confirmed, if right data is received again and within normal range, error is removed.

Remarks: for debugging mode, when model code is not within model range, communication error is confirmed, when model code is within model range, error is removed.

PFC switch value

When PFC sampling current > PFC open switch current and the DC bus average voltage < PFC open switch voltage, then opening PFC;

When PFC sampling current < PFC off switch current, off PFC.

Protection value

#### 4.5 Power module error code checking for 1UH125/140P1ERK

##### 1. Drive Status Indication

LED Model	Explanation of LED display	Position of Led
LED 601 (GREEN )	Flashing (on 1s, Off 1s) : Drive is operating normally. Flashing (on 0.25s off 0.25s, flashes n times and then off 2s as a period) : Module board failure	Module board

##### 2. Protection function

Protection style:

Protection style	Explanation	LED	LED display Description	ERROR Recovery
Shutdown protection	When the voltage, current, temperature, etc. to meet the shutdown protection Level, drive immediately stop output, and LED display fault information, and upload the error symbol.	LED 601 (GREEN)	Flashes n times, off 2s; (n is the error code)	Needs to keep the error information 2min, then ERROR Recovery

##### 3. Shutdown protection error code

Error code	Hardware/software protection	Error detail	Protection Level	Error symbol
1	Software	PIM module overheat	105°C and continued 5s	01H
2	Software	PIM temperature sampling failure	/	18H
3	Software	Overcurrent protection when limit frequency	/	02H
4	Hardware	Hardware protection PIM_INT	PIM_INT	04H
6	Software	DC under voltage	300V	05H
7	Software	DC high voltage	700V	06H
8	Software	Communication error	/	07H
9	Software	Output lack of phase	/	16H
10	Software	Preset	/	/
11	Software	U phase overcurrent	40A	0AH
12	Software	Compressor is out of step	/	0EH
13	Software	V phase overcurrent	40A	0CH
14	Software	W phase overcurrent	40A	0DH
15	Software	Compressor startup failure	/	0FH
16	Software	Phase current sampling failure	/	09H
19	Software	Preset	/	/
20	Software	Preset	/	/
21	Software	Preset	/	/
22	Hardware	Input lack of Phase	/	10H
23		Preset		
24		Preset		
25		Preset		
26		Preset		
27		Preset		
30		Preset		
32		Preset		
34		Preset		

Appendix A Protection function logic and protection level

PIM temperature protection

Temperature more than 105°C, and continue 5 seconds, then drive shutdown protection.

Compressor startup failure protection

The drive will attempt to start the compressor 5 times, at intervals of 15 seconds. When the drive is making five times the driving signal cannot normally drive the compressor, for the protection of the relevant parts, compressor immediately shut down, and the drive will have the compressor drive failure protection.

Limit frequency/shutdown protection

Compressor current protection:

Error protection	Protection condition	Error symbol
Shutdown protection	Compressor phase current > compressor phase current shutdown protection current (RMS) , the compressor immediately stop, drive into the limited frequency overcurrent protection.	
Limit frequency protection	Compressor phase current > compressor Phase current limit frequency protection current (RMS) , the compressor will decrease the frequency by the 2Hz/s rate.	Limit frequency protection
	After compressor decrease the frequency, compressor phase current limit frequency protection current (RMS) ≥ compressor phase current > compressor phase current protection recovery current (RMS) , forbid increase the compressor frequency.	Forbid increase the compressor frequency
Protection recovery	Compressor phase current ≤ Compressor phase current protection recovery current (RMS) , cancel the compressor limit frequency protection and normally operation	

DC bus over/under voltage protection

Bus voltage > overvoltage shutdown value, the compressor stop, then drive into the bus overvoltage protection.

Bus voltage < overvoltage recovery value, cancel the bus overvoltage protection.

Bus voltage < under voltage shutdown value, the compressor stop, then drive into the bus under voltage protection.

Bus voltage > voltage recovery value, cancel the bus under voltage protection.

Communication error

Drive priority detect the model code after power on. the 30s after power on is the time for the model code setting.

And need to complete the model code setting within this 30s, if setting completely, are not allowed to change

Compressor type	Model code
MNB42FFDMC-L	0x03DF

If the model code is not within the model range or the 30s not receive correct communication data, that the communication failure, execute communications shutdown protection, while communication returns the corresponding error code.

After the communication failure, if the receiver again to correct data and models within the model code range, then cancel the error

Note: For debug mode, when the model code is not within the range of models, sentenced to communication failure; when the model code within the model range, then cancel the error

## 1. Compressor type MNB42FFDMC-L:

No.	Error description	Device protection value
1	Compressor phase current Limit frequency protection shutdown current value (RMS)	19.1A
2	Compressor phase current Limit frequency protection decrease frequency current value (RMS)	18.4A
3	Compressor phase current Limit frequency protection recovery current value (RMS)	17.7A
4	PIM temperature shutdown protection	105°C
5	DC bus overvoltage shutdown value	700V
6	DC bus overvoltage recovery value	650V
7	DC bus under voltage shutdown value	370V
8	DC bus under voltage recovery value	430V
9	Communication shutdown protection time	30S



**5. Instructions of parameters & error code checking**

**5.1 From where to do the parameters checking work?**

One digital LED display and 4 button switches which on the outdoor main control PCB

**5.2 Where are the digital LED display and the button switches?**

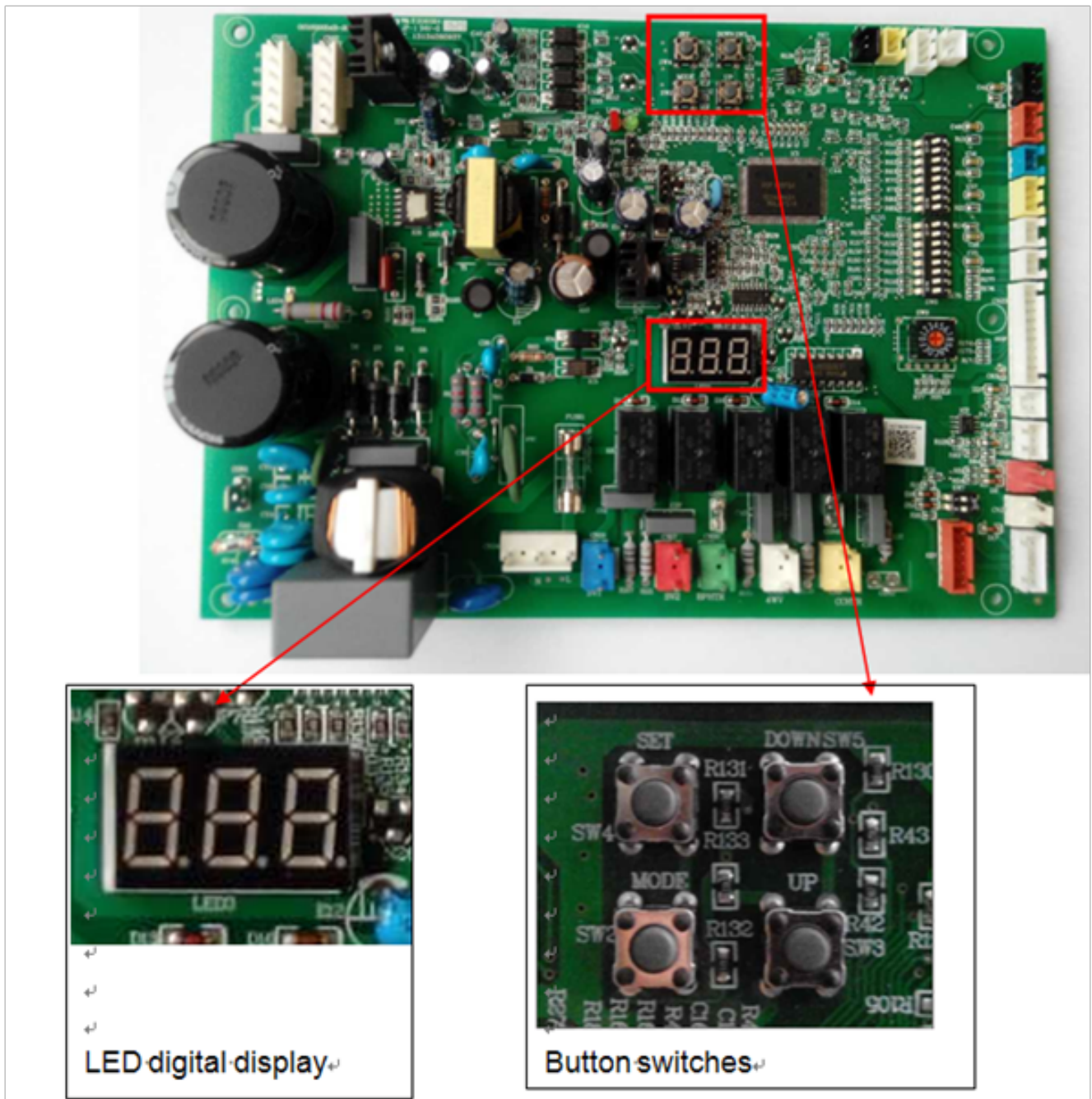

### 5.3 What does the default display at non-checking mode?

It will following the steps below:

a. When outdoor unit gets power, the LED digital display will show the model's code first, as following list.

MODEL	MODEL CODE	DISPLAY
1UH071N1ERG	24.1	24.1
1UH090N1ERG	30.1	30.1
1UH105N1ERG	36.1	36.1
1UH125P1ERG	48.2	48.2
1UH140P1ERG	60.2	60.2
1UH125P1ERK	48.4	48.4
1UH140P1ERK	60.4	60.4

b. Then after step a, if the communication between indoor & outdoor unit established correct, the LED digital display will show the quantity of indoor units.

For single splits system, it will show 1UN.

1UN — 1:1

For MAXI split system, it will show 2UN or 3UN or 4UN

2UN — 1:2  
3UN — 1:3  
4UN — 1:4

c. Then after step b and if has reached the outdoor unit's start time, the LED digital display will indicate the indoor unit's setting mode, cool or heat. This show will last 5 seconds.

COOL — COOL    HEAT — HEAT

d. Then after step c and it will show the speed of the Rotational speed of the compressor rotor, 000 stands for speed is 0 RPS, 15 stands for speed is 15 RPS, 49 stands for speed is 49 RPS, and so on.

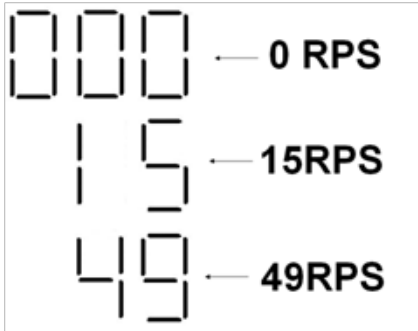

e. Then after step d, if the indoor ambient temperature achieved the point which the outdoor unit should stop, the LED digital display will show 000 first, 30seconds later, if indoor ambient temperature does not achieved the point which the outdoor unit should start again the LED digital display will extinguished. If turn off the indoor unit by controller manually, the LED digital display will show OFF first, 30seconds later, if no start again signal received by the indoor unit, the LED digital display will extinguished.

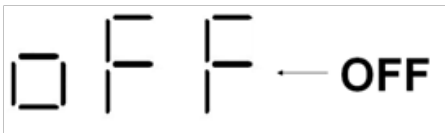

#### 5.4 How to enter the parameters checking mode?

Step1: Press and hold the MODE button for 5 seconds then release, then the LED digital display will show the current mode and will keep flashing.

Step2: Press and hold the SET button for 3 seconds then release, LED digital display will keep the mode lit without flashing.

Step3: Press and hold the SET button for 3 seconds again then release, LED digital display will "frq" and number will flashing alternately by LED digital display. This scene showing the current compressor speed.

Step4: Scroll pages to view the other parameters by UP or DOWN button, parameters include electro-expansion valve opening, indoor or outdoor unit fan speed level, temperature detected by indoor or outdoor unit's sensor, indoor set temperature, compressor current, and so on.

Fig. 4.1 or Fig. 4.2 shows steps above.

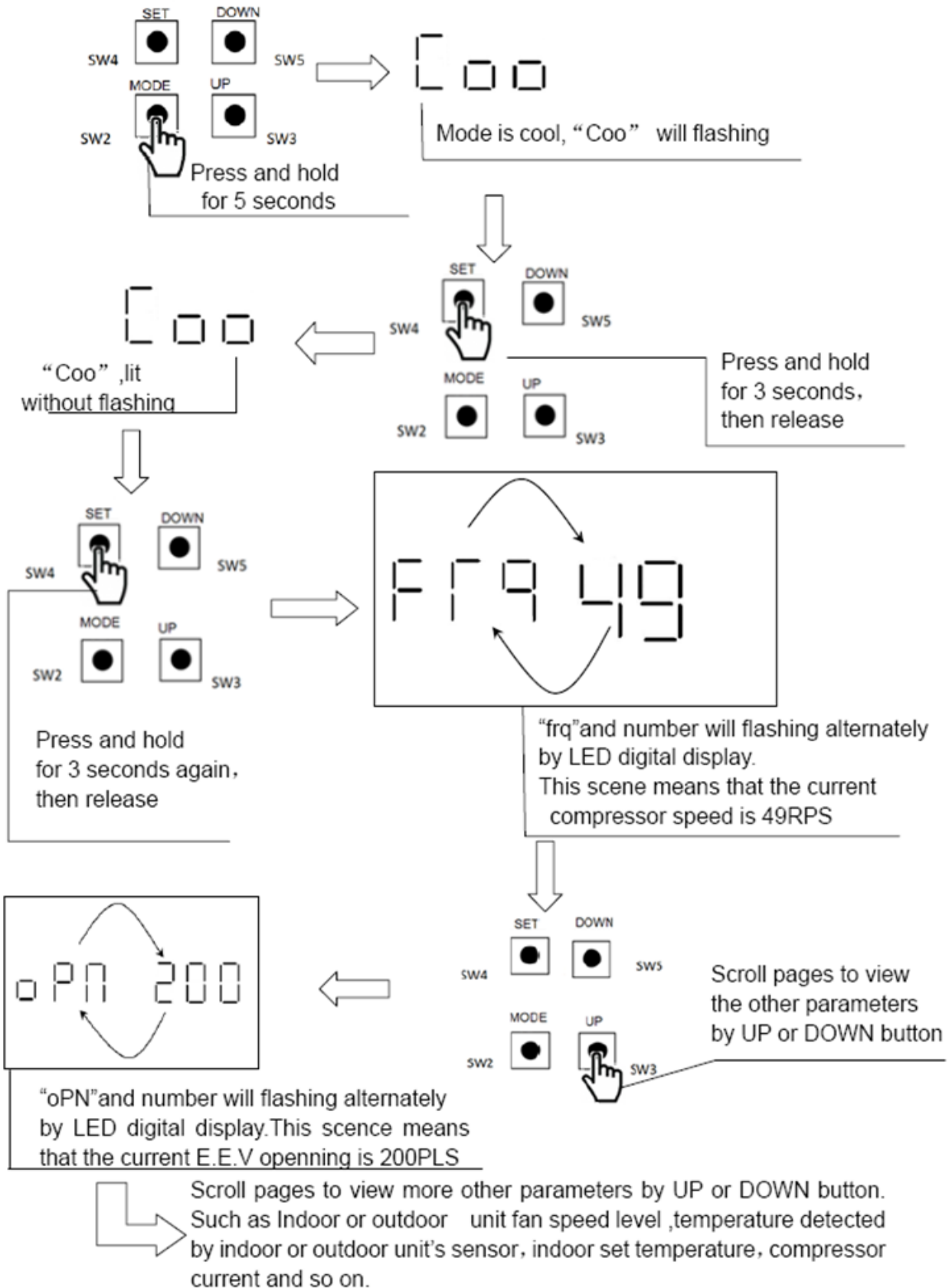

Fig.4.1

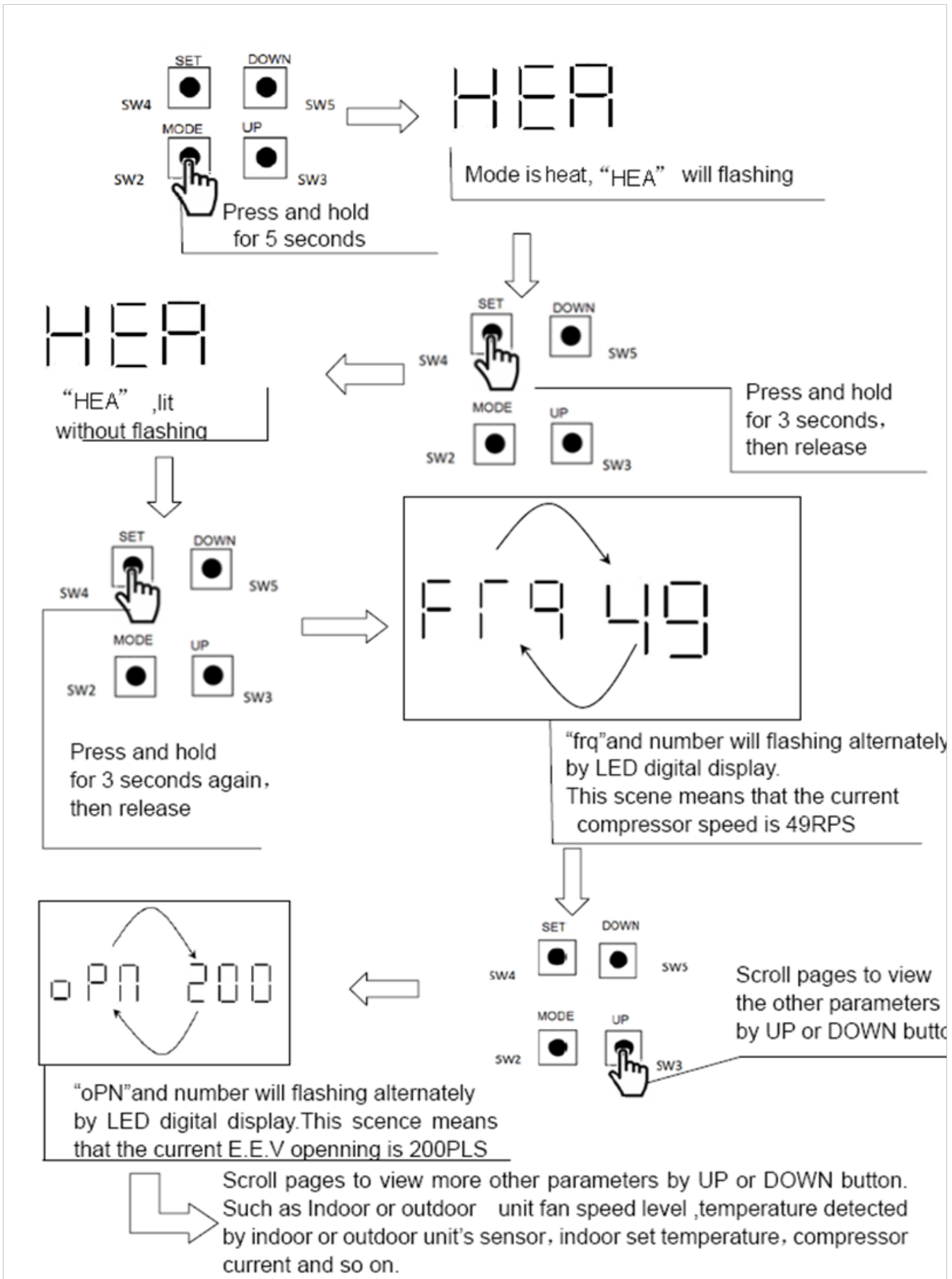

Fig.4.2

## 5.5 Explanation about outdoor unit LED digital display

No.	Symbol	LED digital display	Explanation
1	Coo	Coo	Cool mode
2	HEA	HEA	Heat mode
3	Fan	FAN	Fan mode
4	rrC	rrC	Refrigerant Recovery
5	Stb	Stb	Manually forced stand by
6	OFF	OFF	Compressor at OFF status
7	dIA	dIA	Diagnose
8	dEF	dEF	Manually forced defrost
9	pAr	pAr	Parameters checking
10	Co.N	Co.N	Cool mode of EER test condition
11	Co.A	Co.A	Cool mode of SEER test condition A
12	Co.b	Co.b	Cool mode of SEER test condition B
13	Co.C	Co.C	Cool mode of SEER test condition C
14	Co.d	Co.d	Cool mode of SEER test condition D
15	Co.E	Co.E	Cool mode of SEER test condition E
16	Co.F	Co.F	Cool mode of SEER test condition F
17	Co.H	Co.H	Cool mode of SEER test condition F
18	CO.I	CO.I	Cool mode of SEER test condition I
19	CO.J	CO.J	Cool mode of SEER test condition J
20	Ht.N	Ht.N	Heat mode of EER test condition
21	Ht.A	Ht.A	Heat mode of SCOP test condition A
22	Ht.b	Ht.b	Heat mode of SCOP test condition B
23	Ht.C	Ht.C	Heat mode of SCOP test condition C
24	Ht.d	Ht.d	Heat mode of SCOP test condition D
22	Ht.E	Ht.E	Heat mode of SCOP test condition E

No.	Symbol	LED digital display	Explanation
23	Ht.F	Ht.F	Heat mode of SCOP test condition F
24	Ht.H	Ht.H	Heat mode of SCOP test condition H
25	Ht.I	Ht.I	Heat mode of SCOP test condition I
26	Ht.J	Ht.J	Heat mode of SCOP test condition J
27	quit	quit	Quit
28	Frq	Frq	Frequency (speed of compressor, equals revolutions per second (RPS) ).
29	opN	opN	Electronic expansion valve opening
29	I.FN	I.FN	Indoor unit fan speed level
30	o. FN	o. FN	Indoor unit fan speed level
31	tAo	tAo	Temperature of outdoor ambient
32	tc	tc	Temperature of outdoor condenser
33	td	td	Temperature of outdoor discharge
34	tE	tE	Temperature of outdoor defrost
35	tS	tS	Temperature of outdoor suction
36	tdr	tdr	Temperature of compressor driver module
37	ldr	ldr	Current of the compressor
38	tH	tH	Temperature of heat water (reserved)
39	tAI	tAI	Temperature of indoor ambient
40	TCI	TCI	Temperature of indoor condenser
41	tSt	tSt	Setting temperature on indoor unit
42	UN	UN	UN=UNIT, 1UN means with 1 indoor unit: 2UN means with 2 indoor unit, MAXI application
43	r32	r32	Refrigerant R32
44	OiL	OiL	Unit gets compressor oil recycling mode

### 5.6 Checking current outdoor unit error code

If there is malfunction on the outdoor unit, the LED digital display will flashing like this repeating pattern:

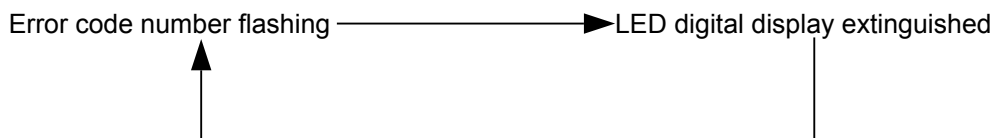

Example:

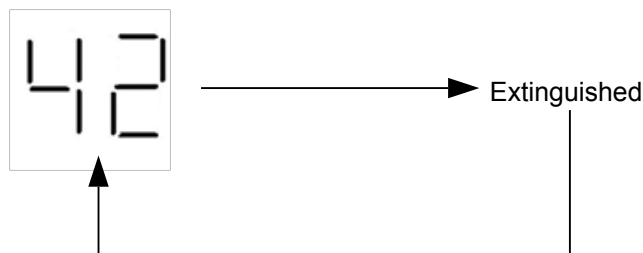

Refer to the outdoor unit's trouble shooting table to get what the error code means and follow the recommend.

### 5.7 View previous error record (diagnosis mode)

Step1: Press and hold the MODE button for 5 seconds then release, then the LED digital display will show the current mode and will keep flashing.

Step2: Scroll pages to view the other modes by UP or DOWN button.

Step3: Continue with step 2, find mode "dig", press and hold the SET button for 3 seconds, then release.

Step3: Continue with step 3, press and hold the SET button for another 3 seconds, then release, the LED digital display will show the error code last time.

Step4: Scroll pages to view the other last 10 times error code by UP or DOWN button. If only N ( $N \leq 10$ ) error been recorded, you can just find last N times' error record.

Fig.7.1 shows steps above.



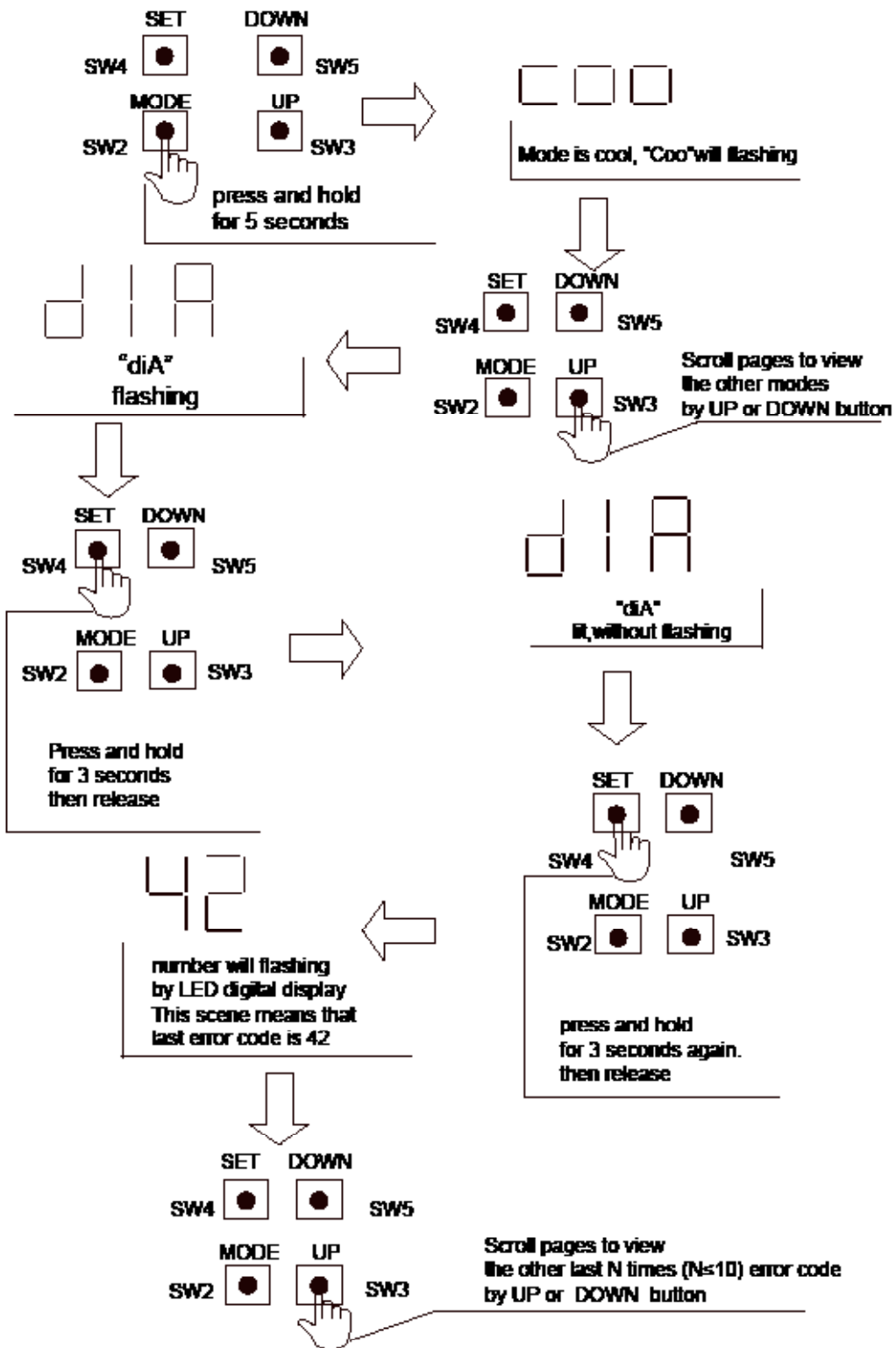

**5.8 How to quit the parameters checking mode or diagnosis mode**

Step1: Press and hold the MODE button for 15 seconds then release, then the LED digital display will show "quit".



Step2: Press the SET button to quit the parameters checking mode or diagnosis mode.

## 6. Function

### 6.1 Indoor unit

#### 6.1.1 Dehumidification operation (no humidity sensor )

1. Indoor unit will stop and send a stopping signal to outdoor unit when  $T_{ai} < 16^{\circ}\text{C}$ .
2. Indoor unit will running cooling mode and send a cooling mode to outdoor unit when  $T_{ai} > T_{set} + 2^{\circ}\text{C}$ .
3. When  $T_{set} < T_{ai} \leq T_{set} + 2^{\circ}\text{C}$ , indoor unit send a dehumidification mode signal to outdoor unit. Indoor unit run 10 minutes in low speed, and stop 6 minutes, the S-Code=0, alternate running. When it stops it will send stopping signal to outdoor. When indoor unit failure, it will run 10 minutes in low speed and stop 6 minutes. Timing cycle keep the same. Slave units determine the fan speed through the state what outdoor sent.
4. When the room temperature less than or equal to setting temperature, the indoor unit blow low speed and sent a stopping signal to outdoor unit.

#### 6.1.2 Auto running:

For cooling only units, auto running only have two modes: cooling and blowing.

1. First time to enter auto running mode, the running mode is decided by outdoor mode, room temperature and setting temperature: If outdoor units have been running, it will run according to outdoor units mode (only for multi mode) . Or when  $T_{ai} \geq T_{set}$ , it will enter auto cooling mode. When  $T_{ai} < T_{set}$ , it will enter auto heating mode.
2. Auto cooling mode is same to cooling mode. The unit will enter auto heating mode if  $T_{ai} + 1 + T_{dif} < T_{set}$  after temperature sensor off 15 minutes. Or it will still stay on cooling mode, and will stop after reaching the setting temperature.
3. Auto heating mode is same to heating mode. The unit will enter auto cooling mode if  $T_{ai} \geq T_{set} + 1 + \text{corrected} + T_{dif}$  after temperature sensor off 15 minutes. Or it will still stay on heating mode.
4. This mode has sleep function. In cooling mode it will enter cooling sleep, the same to heating. Once set sleep function, the unit will no longer change mode after reaching setting temperature and stopping 15 minutes.
5. Cooling and heating mode transformation only can be carried out in 15 minutes after compressor stopping. Slave units determine the fan speed through the state what outdoor sent.

#### 6.1.3 Indoor fan control

1. Auto fan speed control

Cooling mode  $\Delta T = T_{ai} - T_{set}$  ; heating mode  $\Delta T = T_{set} - T_{ai}$

\*First time to enter auto wind mode, when  $\Delta T > 2$ , choose high speed;  $\Delta T \leq 0$ , choose low speed, another choose middle speed. If temperature sensor is off ,choose low speed. (1 degree transformation temperature difference)

When the speed mode is auto high speed, if  $\Delta T < 2$ , the speed mode will change to auto middle speed.

When the speed mode is auto middle speed, if  $\Delta T < 0$ , the speed mode will change to auto low speed; if  $\Delta T > 3$ , the speed mode will change to auto high speed.

When the speed mode is auto low speed mode, if  $\Delta T > 1$ , the speed mode will change to auto middle speed.

The speed transformation under auto speed mode: It will delay 3 minutes from high speed to low speed and no delay from low to high.

Salve units determine the fan speed according to the state what outdoor has sent in the auto speed mode.

2. Cold wind prevention control

It is unavailable in the cooling mode (include auto cooling mode) , dehumidification mode and blowing mode. In heating mode, the indoor fan running state is decided by indoor coil temperature ( $T_m$ ) after compressor starting.

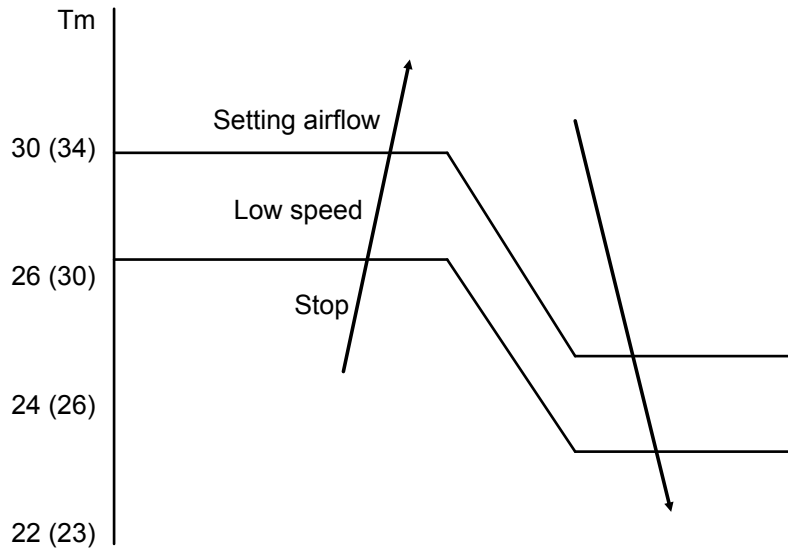

**Note:**

The numbers in the brackets is the temperature control point when the outdoor environment temperature is more than 10 degree.

3. Afterheat control

Unit is off in heating mode or S-0 or compressor is off, unit will run in after-heat mode. The indoor unit fan run at a low speed until it satisfy the conditions what has been line out in above table. (cold wind prevention priority) . The longest running time is 50 seconds.

4. Cold wind prevention control in defrost mode

After receive the defrost signal, indoor unit will blow after-heat for 20 seconds in low speed and then stop. Or it will stop if indoor coil temperature is less than the temperature of cold wind prevention. After defrost, indoor unit fan will run in cold wind prevention mode.

**6.1.4 Anti-freeze**

Anti-freeze protection, pay attention that the LED light of outdoor can display the anti-freeze protection, but indoor cannot display it because it's not a fault and can recover itself automatically.

Anti-freeze protection of indoor unit in cooling mode

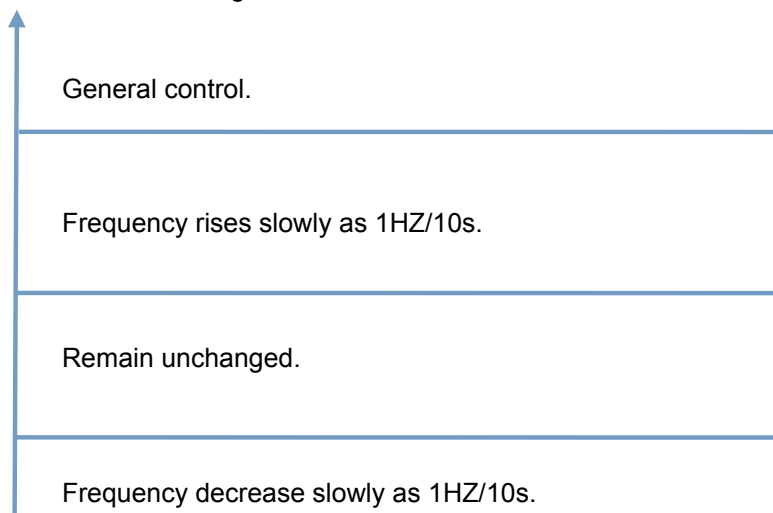

When  $TM < 6^{\circ}\text{C}$ , the compressor frequency will decrease at the speed of 1HZ/10s;

When TM start to rise again, and  $6^{\circ}\text{C} \leq TM \leq 8^{\circ}\text{C}$ , the compressor frequency will remain unchanged.

When  $8^{\circ}\text{C} < TM \leq 10^{\circ}\text{C}$ , the compressor frequency will rise at the speed of 1HZ/10s.

When the state of  $TM < 2^{\circ}\text{C}$  lasts for 10s after 6 minutes of the startup of the compressor, or the state of  $T < -20^{\circ}\text{C}$  (E) lasts for more than 2 hours in cooling mode, the compressor will stop. Shut down the units for 5 minutes (E) and the temperature of the coil rise to  $10^{\circ}\text{C}$  (E), it will be back up and running.

#### 6.1.5 Control of float switch and drainage pump

1. In cooling (including cooling automatically and emergent switch setting cooling) and dehumidification mode, the drainage pump will work when the compressor startup and will stop working after 5 minutes when the compressor shuts down.
2. In convert heating and other modes, the drainage pump also keep working for 5 minutes and predicate execution according to the mode.
3. Detecting the full water signal for more than 5 minutes, the compressor will stop working; The water drainage pump will keep working for 5 minutes after the compressor stops, if the float switch is still off, then the drainage system will show errors, the water drainage pump will keep working after the error comes out until 5 minutes after detecting the float switch is off.

#### 6.1.6 Emergent switch control

##### 1. Emergent running

Press the emergent switch when shutting down the unit, the indoor unit will startup at \*\*\* mode automatically, the speed of the wind is automatic, setting temperature is  $24^{\circ}\text{C}$ , press the emergent switch when starting up the unit, the indoor unit will shut down, then it come to the normal control.

##### 2. Test run

When in shut down state, keep pressing the emergent button, you will hear two buzzers after 5 seconds and then release the button to remember the last shutdown mode, if it's cooling mode last time, it's cooling, high speed wind and setting  $16^{\circ}\text{C}$  now, if it's heating mode, it's heating, high speed wind and setting  $30^{\circ}\text{C}$  now, the way to quit this: wired controller to start up or shut down the unit, remote controller to start up or shut down the unit, emergent switch.

#### 6.1.7 Room card control (default is valid)

Room card invalid: if room card is invalid, using room card to turn ON/OFF (ON when close and OFF when open) is valid, similar function to other controller.

Room card valid: if room card is valid, indoor will operate only when room card closes and then receives ON order from other controllers.

#### 6.1.8 Auto restart function:

1. When using wired controller: auto restart function is default valid (no need to set)
2. When using remote controller: press continuously 10 times of sleep key in 5s, indoor beeping 4 times to enter auto restart function; press continuously 10 times of sleep key in 5s, indoor beeping 2 times to quit auto restart function;

Memorized content of auto restart: ON/OFF state, mode, fan, set temp, health, swing position;

If timing or sleeping function is set, when power on again, they will be cancelled.

#### 6.1.9 Forced defrosting:

1. When using remote controller: when outdoor in heating or off state, set high fan,  $30^{\circ}\text{C}$ , press sleep key 6 times in 5s, and indoor beeps 3 times to enter manual defrosting. It is the same as heating defrosting.
2. When using wired controller or invisible LED: it will receive corresponding forced defrosting signal and enter defrosting.

**6.1.10 Timing operation:**

- 1) When using wired controller, unit will be controlled ON/OFF by wired controller
- 2) When using remote controller, unit will be ON/OFF according to set time by remote controller and current time.

**6.1.11 Sleeping function:**

- 1) When using wired controller, unit will be controlled ON/OFF by wired controller
- 2) When using remote controller, press sleep key to set sleep function including sleeping in heating and sleeping in cooling. After setting sleeping function and then shift mode, sleeping will recount.

**6.1.12 Swing control:**

- 1) When choosing 2HP cassette swing.  
When powering on and initializing, it will firstly open to biggest opening for positioning, and then enter basic opening, fan motor operating after blade moving to right position.
- 2) When choosing 3-5HP cassette, swinging will be controlled by invisible LED.  
It will swing according to default position when first powering on, and will swing according to swing position before turning off.

**6.1.13 External static pressure setting method ----for AD105/125/140M1ERG**

There are 2 ways to achieve the externalstatic pressure setting:

- A. by Infrared remote controller ;
- B. by wired controller.

MOEDL	Static pressure level ( N )	Externalstatic pressure	Select by Infrared remote controller	Select by wired controller
AD105M1ERG AD125M1ERG AD145M1ERG	1	30Pa	YR-HBS01 +RE-02→FAN mode ,fan speed high→press HEALTH button 4+N times(1≤N≤10,integer) within 12 seconds	Select static pressure Level N by the display interface
	2	40Pa		
	3	50Pa		
	4	60Pa		
	5	70Pa		
	6	80Pa		
	7	90Pa		
	8	100Pa		
	9	110Pa		
	10	120Pa		

**A.By Infrared remote controller**

1. Prepare: Infrared remote controller YR-HBS01 , infrared remote receiver RE-02(plug RE-02 connector to indoor PCB CN29)

2. Method:

Step 1: set the Infrared remote controller at condition: FAN mode ,fan speed high

Step 2: then aim the remote controller at the infrared remote receiver RE-02, press HEALTH button 4+N times(1≤N≤10,integer) within 12 seconds ,then the receiver will beep N+1 times, the static pressure level N is been set successfully.

Note: For Infrared remote controller YR-HBS01, need press ON/OFF button make the controller's at OFF status first, then open the button cover press FRESH button will enter FAN mode interface.

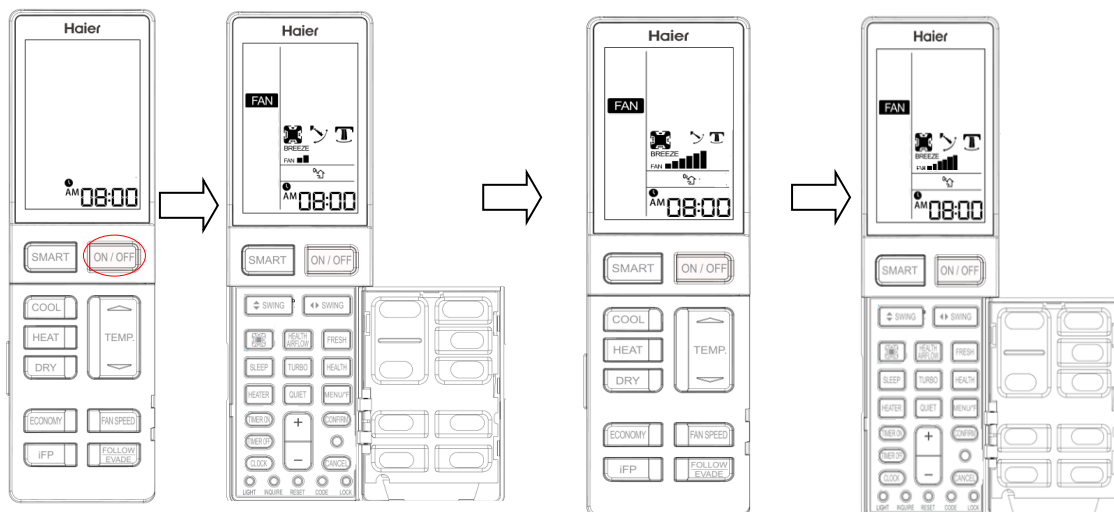

## B.By wired controller

1. Prepare: wired controller YR-E17, plug wired controller connector to indoor PCB CN3

2. Method:

2.1 In the state of ON and non screen saving state, press Fan + Set keys for 5s to enter static pressure grade adjustment.

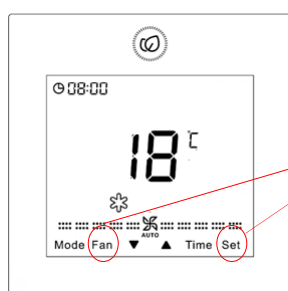

Press together and hold for 5 seconds

2.2 State with static pressure icon flashing and current static pressure grade statically displaying.

2.3. Press key ▼ ▲ to change static pressure grade  $N(1 \leq N \leq 10, \text{integer})$ , then press Set key to confirm.

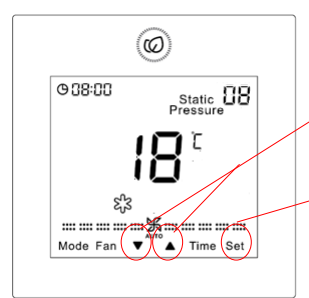

Use these buttons to adjust static pressure level numbers.

press Set key to confirm.

6.2 Outdoor unit

6.2.1 Compressor discharge temp. (TD) high temp. protection function.

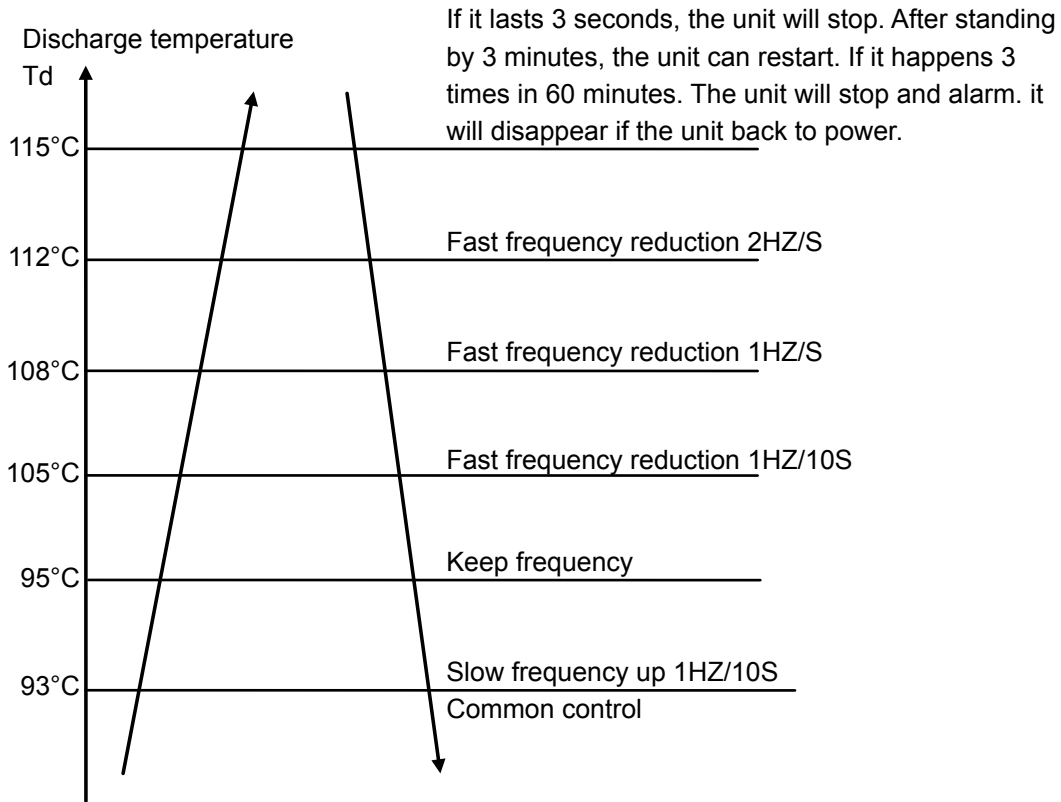

6.2.2 Condenser overheat protection

When cooling, compare TC with TE. Choose the bigger one, TC'.  $TC' = \text{MAX.}[TC, TE]$ . You can control the high pressure through controlling TC'.

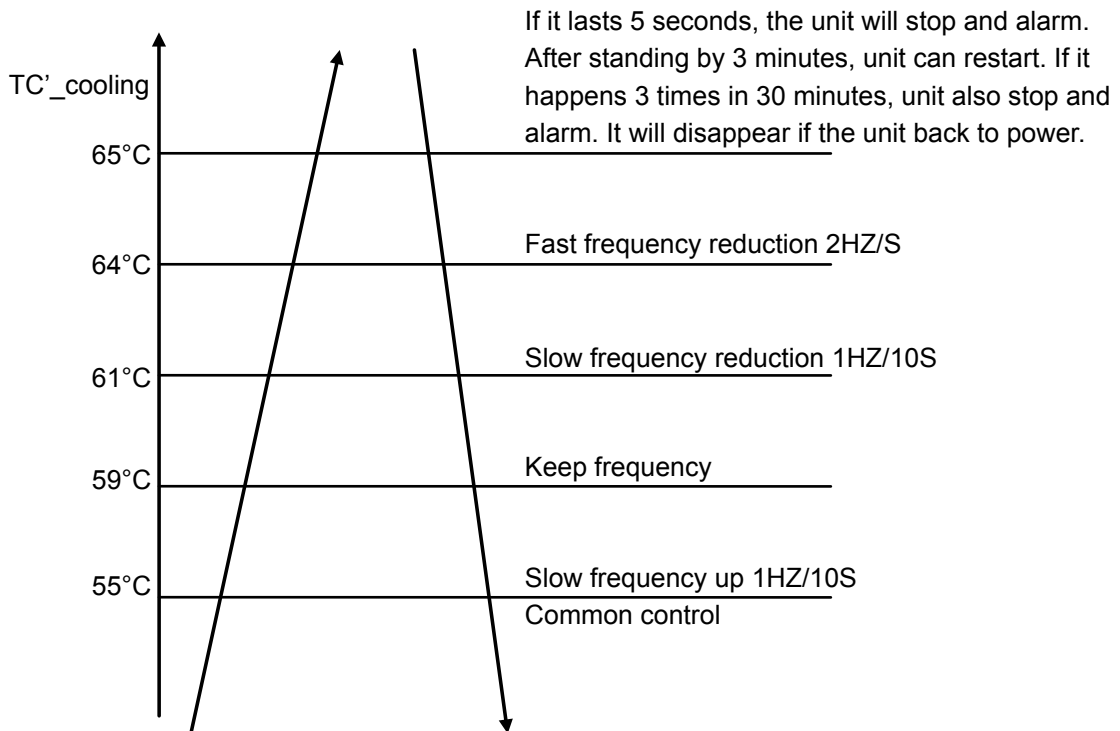

### 6.2.3 Low pressure protection

In order to realize low pressure protection, the low pressure is controlled by simulating evaporating temperature: When cooling, compare the evaporating temp. with the compressor suction temp. and choose the lower one (Teva c) to simulate judgment.

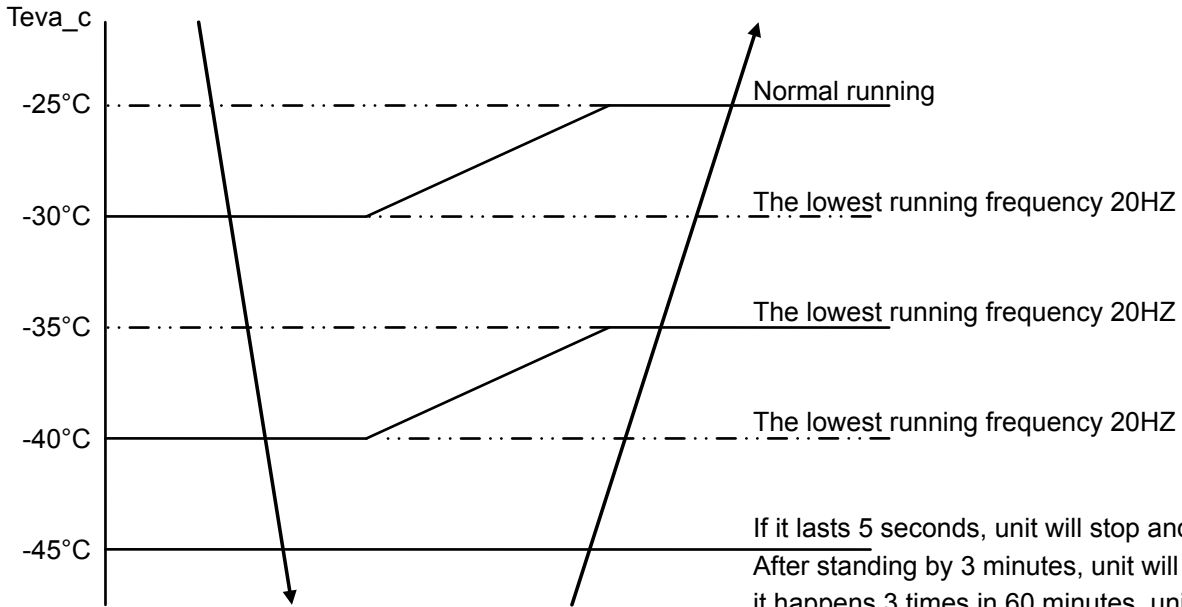

If it lasts 5 seconds, unit will stop and Alarm. After standing by 3 minutes, unit will restart. If it happens 3 times in 60 minutes, unit will stop and alarm for ever. It will disappear if unit back to power.

When heating, you can judge through comparing defrost temp. (Te) with environment temp. (Tc) and choose the lower one (Teva h) .

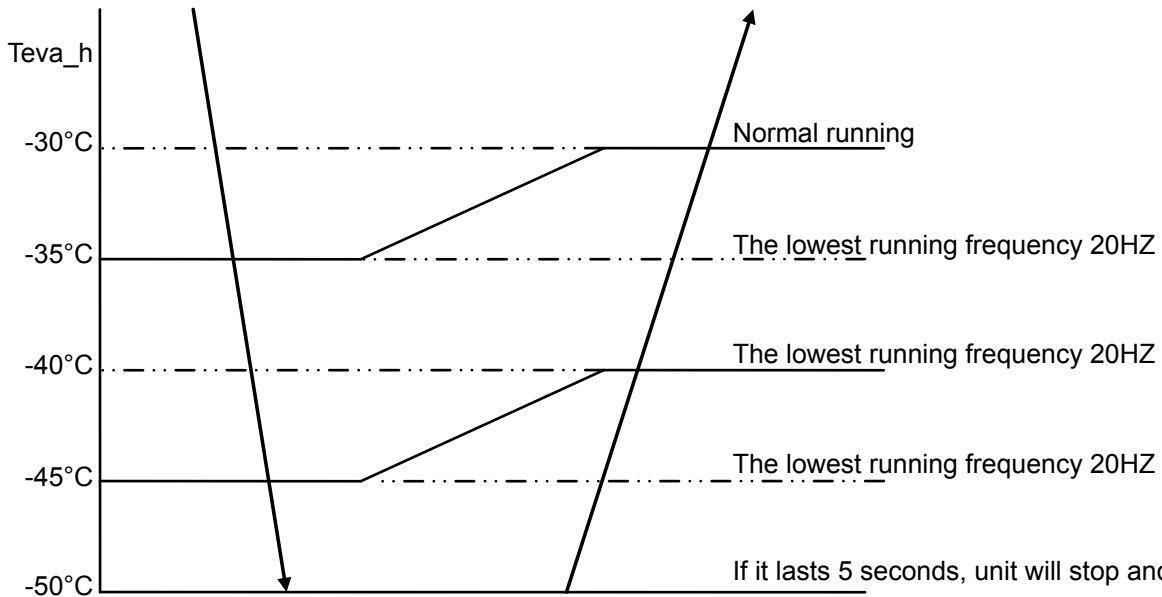

If it lasts 5 seconds, unit will stop and Alarm. After standing by 3 minutes, unit will restart. If it happens 3 times in 60 minutes, unit will stop and alarm for ever. It will disappear if unit back to power.



**6.2.4 Oil return control**

Control purpose: Make the system oil regularly return to the compressor when the compressor work in a low frequency.

Condition:

When the indoor units are working, if the compressor continuous frequency is lower than the parameters C HZ (E) and the temperature TC is lower than 50°C (E) ,and it lasts 5 hours. Unit will enter oil return mode. When changing the mode or manual stop or protective stop, time will pause. After the compressor restart, it will continue to time.

When timing, if the compressor working frequency is higher than B HZ (E) and lasts more than 10 minutes, the time reset.

When heating, the time will reset if the defrost mode work.

After oil return, oil return timer reset

Process control chart of oil return

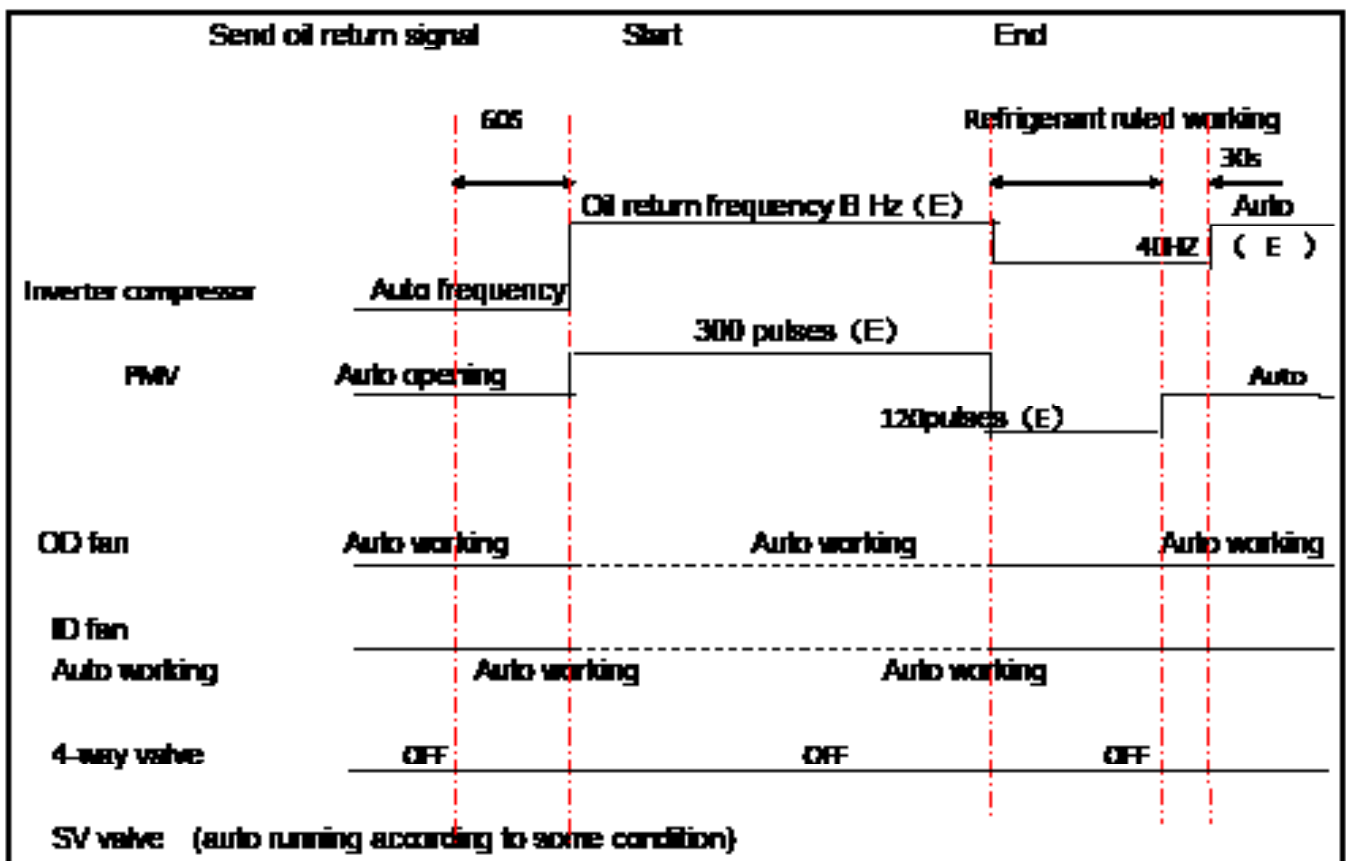

After oil return, the condition of end of refrigerant ruled running

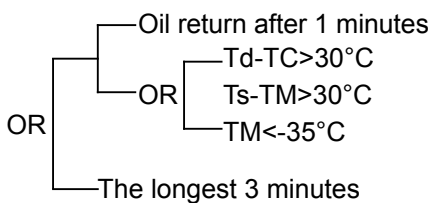

Process control chart of oil return

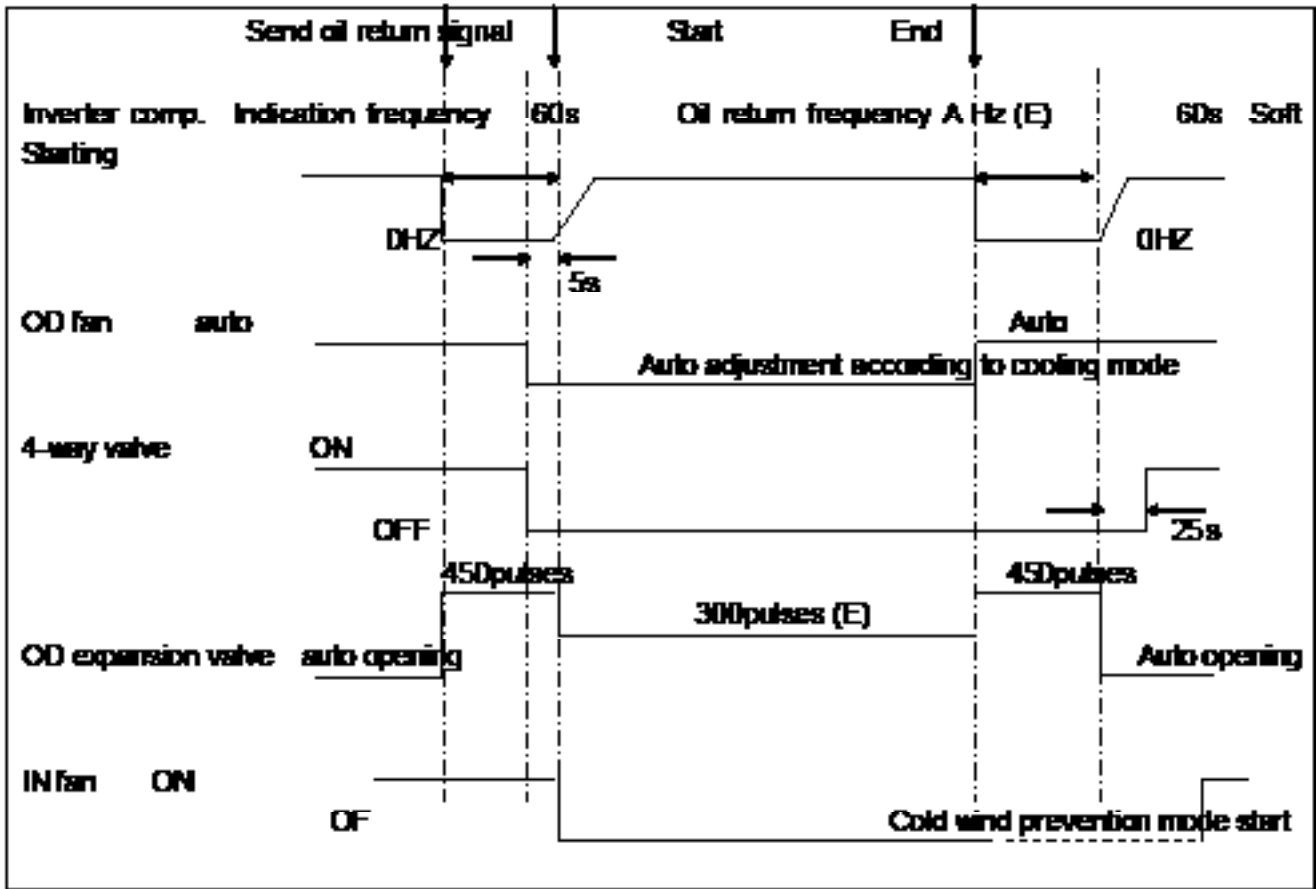

- OR
  - The longest 9 minutes
    - OR
      - $T_d - T_C < 20^\circ\text{C}$  lasts 30 minutes (it will start to judge after oil return lasting 30 seconds.)
      - $T_s - T_M < 15^\circ\text{C}$  lasts 30 minutes (it will start to judge after oil return lasting 30 seconds.)
  - The shortest running 3 minutes

### 6.2.5 Control of operating EEV

1. Set one general EEV on outdoor unit board, control the EEV by indoor unit, outdoor unit board is regarded as executing agency.
  - (1) Reset the electrify valve: act one full-closed action when the first electrifying of the outdoor valve board.
  - (2) Power source: switch power source, outdoor unit 13.5V (input voltage of the EEV) are the same line.
2. The electronic property of the EEV

Largest opening	500 pulse
Driving speed	PPS

Remark: considering the application of MAXI, the EEV of each model should be larger, when operating as one outdoor unit with one indoor unit, the opening of the EEV should be stable lower than 200 steps. Leave the system adjustment margin of MAXI.

3. The initialization action of the EEV.

Driving speed of the EEV: Open-way: 31.25 PPS (32MS) , Closed-way: 31.25 PPS (32MS)

full open action and full closed action of EEV: full open action: open as 470 pulse (E) , full closed action: after closing 540 pulse, repeat three times (close as 60 pulse and open as 5 pulse, it means stop at opening of 5)

## 4. The limitation of the EEV opening

State of the unit	Requirement of the opening	Lower limit	Upper limit
Shut down	Standard opening of the model, according to the opening of last time	/	/
Standby (temperature sensor off)	Standard opening of the model, according to the mode before the temperature sensor is off	/	/
Cooling startup process	Execute the standard cooling opening of the model	Standard opening	400
Heating startup process	Execute the standard heating opening of the model	150	400
Cooling, dehumidification	Adjust automatically	70	470
Heating	Adjust automatically	70	470
Defrosting	Fixed opening	200	400
Oil return	Fixed opening	150	400
Refrigerant discharge	Fixed opening	150	400

## 6.2.6 Control of shutdown

## 1. Initiative shutdown mode (shutdown normally without protection)

When the air conditioner is in cooling or heating mode, the compressor get the shutdown signal, the current frequency of the compressor is more than 55HZ (EE) , the compressor will decrease to 48HZ at the speed of 2HZ/s and shut down directly.

If the current frequency of the compressor is lower than 55HZ, it will shut down directly after it receives the signal. Avoid that the sudden shutdown will cause too strong stress when in high working frequency.

After the compressor stops, the fan motor will execute the left heat blowing and then stops.

Shutdown because of the anti-freeze protection, the compressor will stop as initiative shut down mode/

## 2. Passive shut down mode (Error protection shut down)

When the system come to the pressure protection, over-current protection, high module temperature protection, high condensation temperature protection and the unit shut down, no matter the frequency of the compressor come to 55HZ, the unit will shut down directly.

## 6.2.7 Defrosting control in heating mode

In heating mode, condenser heat exchanger defrosting condition is detected by outdoor coil temperature sensor, and defrosting is controlled by outdoor ambient temperature and coil temperature.

## 1. Defrosting starting condition:

- 1) After compressor running in heating for continuous 10 minutes (E) and for accumulated 50 minutes (E) , by testing  $T_e$  (defrosting temp sensor) or TC (testing of outdoor exchanger frosting condition) and outdoor ambient temp sensor TA, when it meeting the following condition for continuous 5 minutes, the unit will enter defrosting operation. In case of no defrosting operation caused by imbalanced refrigerant flow (caused by refrigerant lack or other reason) , the unit will enter defrosting when any one of the two conditions are meet.

Entering condition:

$T_e \leq C \times TA - \alpha$  OR  $TC \leq C \times TA - \alpha$  and lasts for 5 minutes

Note: C:

$TA < 0^\circ\text{C}$ ,  $C = 0.8$

$TA \geq 0^\circ\text{C}$ ,  $C = 0.6$

a. Entering temp. limit of defrosting 1:  $-15^\circ\text{C} \leq C \times TA - \alpha \leq -2^\circ\text{C}$

b. Entering temp limit of defrosting 2:  $C \times TA - \alpha < -15^\circ\text{C}$  &  $T_e \leq -15^\circ\text{C}$  for continuous 5 minutes & accumulated running time reaching 90 minutes.

c. Defrosting entering limit condition: indoor coil temp lower than 40 degree

d. Heating mode compressor running accumulated time stop/pause condition:

Detecting stop (end) : shifting from heating to cooling mode

Detecting pause: thermostat OFF, unit off.

## 2. Defrosting end condition:

After defrosting condition starts, it will last no more than 10 minutes (E) . Using  $T_e$  to test outdoor heat exchanger frosting condition, if it lasts over accumulative 60 seconds of  $7^{\circ}\text{C}$  (E) or over accumulative 30 seconds of  $12^{\circ}\text{C}$  (E) or over  $15^{\circ}\text{C}$  (E) , defrosting will stop.

## 3. Forced defrosting control

Starting condition of forced defrosting: in heating operation (including standby state) , unit will start forced defrosting after receiving forced defrosting signal by indoor.

Stopping condition of forced defrosting: refer to 7.3

Indoor manual defrosting signal will keep until outdoor enters defrosting.

**Note:** *It can enter manual defrosting when compressor in OFF state, but it needs to follow 3-minute protection rule.*

## 4. Timing defrosting mode condition:

Starting condition: after setting outdoor function dip switch, it will execute timing defrosting in heating mode.

A. If outdoor ambient temp is over 10 degree (E) , even if timing defrosting is set, it will follow the auto defrosting condition, meaning auto entering and auto quitting.

B. When outdoor ambient temp is lower than 10 degree (E) (including 10 degree ) , it will follow the defrosting operation as below:

When compressor runs for continuous 10 minutes (E) and runs for accumulative 50 minutes (E) , it will enter defrosting operation.

C. Timing defrosting operation and quit condition is the same as auto defrosting.

### 6.2.8 Four way valve control:

1. When powering on, four way valve is in OFF state.

2. In other modes except heating, the four way valve is powered off.

3. In heating mode, when thermostat is off, the four way valve will keep ON, but in heating mode, under the following conditions, four way valve should be OFF.

1) in heating mode, in initial starting time of compressor to ensure the pressure difference ;

1) in defrosting operation:

a, if there is no compressor stopping, power four way valve off;

4. When shifting from heating to other modes, four way valve will power off after a while.

Besides, four way valve will keep powering on when from other mode changing to heating mode.

5. Protection of fault operation of four way valve.

In heating mode, after continuous running of compressor for 10 minutes, if  $T_m$  (indoor sensor)  $<$  indoor ambient temp  $-2^{\circ}\text{C}$  (E) and  $T_e$  (outdoor sensor)  $>$   $15^{\circ}\text{C}$  (E) for continuous 1 minute, four way valve will be powered off, reporting four way valve error. But if start after 3 minutes, and it happens 3 times continuously in 1 hour, it will report four way valve switching error. It will not detect in heating defrosting and within 10 minutes after quitting defrosting; It will not detect in heating oil return and within 10 minutes after quitting oil return;

6. Only in initial starting of compressor of heating mode, outdoor fan motor and four way valve will powering on simultaneously.

7. If compressor frequency is higher than regulated frequency before off, it will lower to required frequency and then stop.

8. Compressor inverter frequency and outdoor fan speed will operate in accordance with other requirement.

Defrosting time sequence is as follows

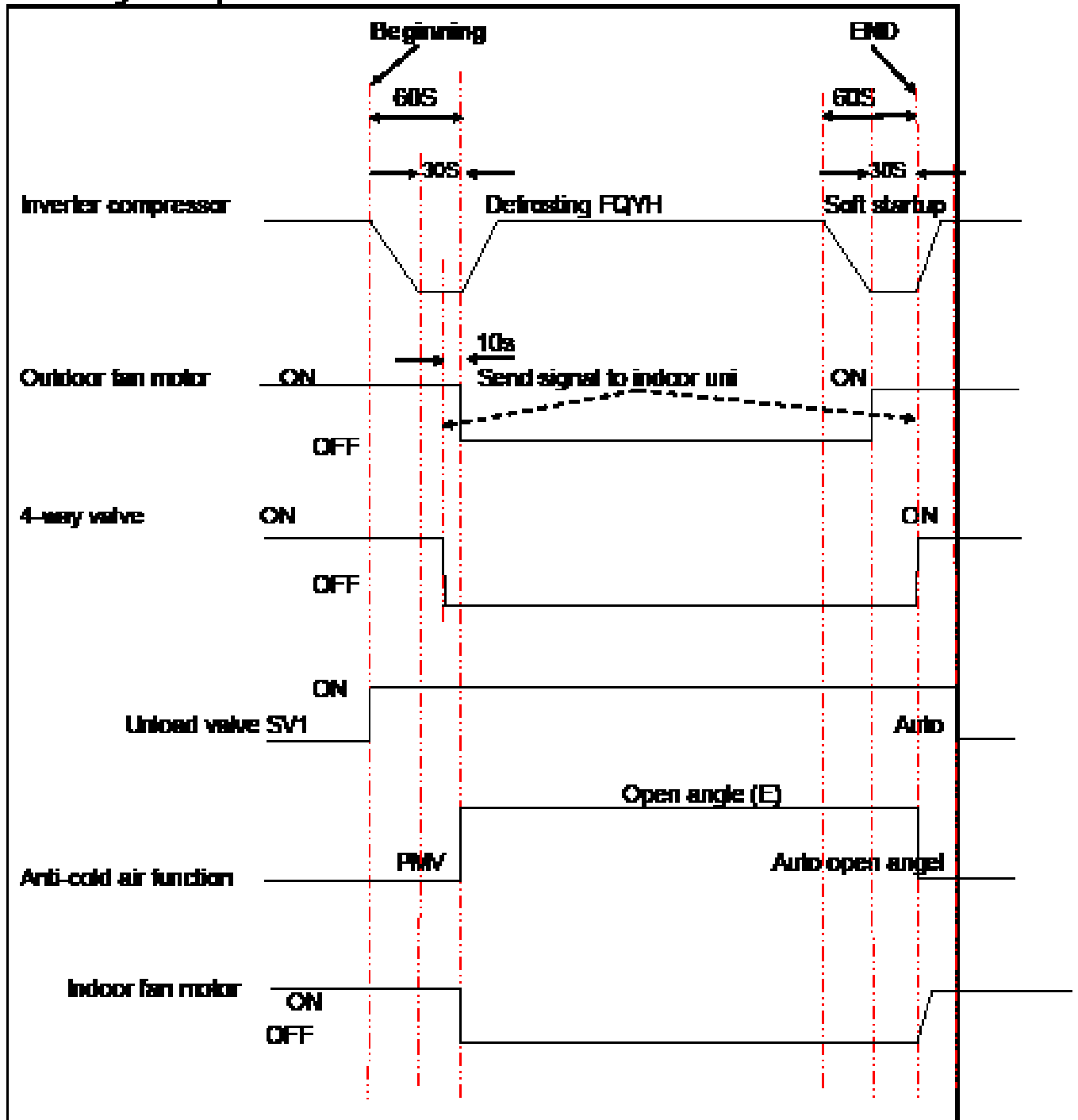

## 7. Controller

### 7.1 Remote Controller: YR-HBS01

External View of Remote Controller

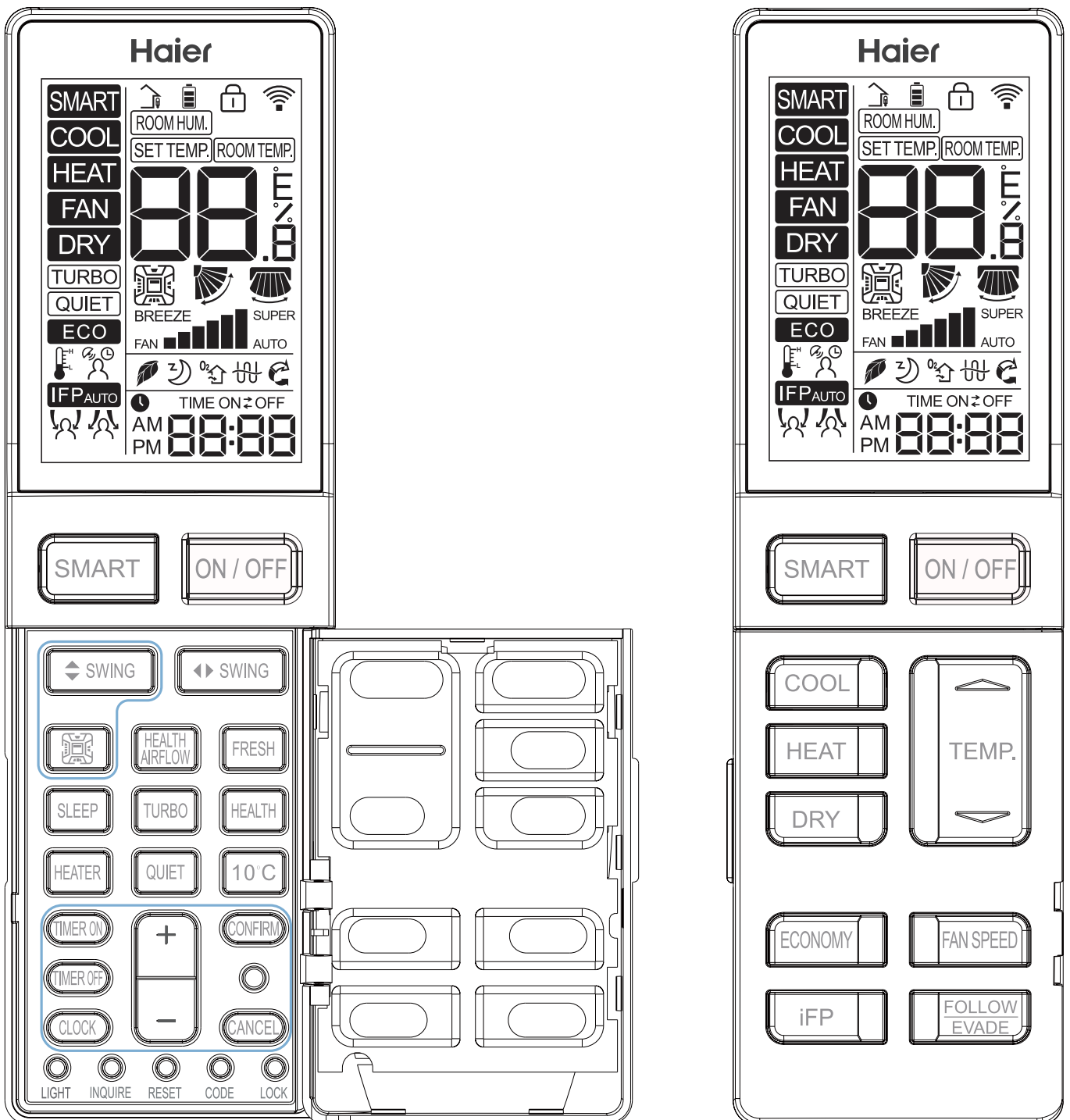

**Loading of the battery**

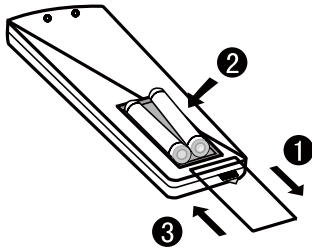

- 1.Remove the battery cover
- 2.Insert 2 AAA batteries as illustrated noting battery polarity
- 3.Reinstall the battery cover

**Note:**

The distance between the signal transmission head and the receiver hole should be within 7m without any obstacle as well. When electronic-started type fluorescent lamp or change-over type fluorescent lamp or wireless telephone is installed in the room,the receiver is apt to be disturbed in receiving the signals,so the distance to the indoor unit should be shorter.

Full display or unclear display during operation indicates the batteries have been used up. Please change batteries. If the remote controller can't run normally during operation, please remove the batteries and reload several minutes later.

**Hint:**

Remove the batteries in case won't be in use for a long period. If there is any display after taking-out, just press reset key.

**Functional description:**

**1. Power-up and Show All:** the LCD display shows all symbols in this function. 3s later, it just shows time and the initial time is AM 12:00. The initial time is adjustable and will be confirmed automatically 10s later.

**2. ON/OFF Button:** press the button for power on. The initial default mode is SMART, otherwise it will be the mode before power OFF. Press OFF button after power on.

**3. SMART Button:**

- (1) SMART button is always valid during power ON/OFF;
- (2) Press SMART button to execute power OFF in SMART mode;
- (3) In OFF and other modes, press SMART button to enter initial default setting of SMART mode. LCD setting temperature is not showed;
- (4) In SMART mode, press TEMP. +/- button to show the setting temperature.

**4. COOL Button, HEAT Button and DRY Button**

(1) When the remote controller in ON, press COOL button, HEAT button and DRY button to execute COOL mode, HEAT mode and DRY mode.

(2) For initial power-up, temperature and fan speed will be showed as follows when entering each mode, otherwise parameters set last time will be showed;

Mode	SMART	HEAT	COOL	DRY	FAN
Initial TEMP.	24°C	24°C	24°C	24°C	Setting temperature is not showed.
Mode	SMART	HEAT	COOL	DRY	FAN
Initial Fan Speed	AUTO	LOW	HI	AUTO	LOW

**5. FAN Mode**

(1) During power OFF, press "HEALTH" button or "FRESH" button to enter FAN mode with low fan speed. Meanwhile, the HEALTH or FRESH icon will be showed on the screen.



(2) Temperature is not showed in FAN mode.

(3) Auto fan speed is not available when switching fan speed in FAN mode.

**6. FAN SPEED Button:**

(1) In other modes except for Fan mode, LOW, MED, HI and AUTO fan speed is adjustable, switching sequence is as LOW-MED-HI-AUTO-LOW.



(2) After TURBO or QUIET is set. Press TURBO button to show **TURBO** on the screen with fan speed as , then press "FAN SPEED" button to exit; press QUIET button to show **QUIET** on the screen with fan speed as , then press "FAN SPEED" button to exit. To cancel TURBO and QUIET, press TURBO and QUIET buttons respectively, **TURBO** and **QUIET** icons will disappear and the fan speed will return to the last one.

(3) This button is invalid during power OFF.

### 7. TEMP. +/- Button:

(1) This button is invalid in FAN mode;

(2) Temperature adjustment range in SMART, HEAT, COOL and DRY mode: 16 ~30°C.

(3) Press and hold "TEMP. +/- " button, the temperature changes once; long press the button, the temperature changes rapidly.

### 8. Four-side Embedment (Available for some models):

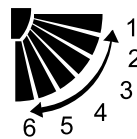

(1) Initial position of all modes for first power on:

	SMART	HEAT	COOL	DRY	FAN
Four-side Embedment	Show all	Show all	Show all	Show all	Show all
SWING Angle	Position 3	Position 5	Position 3	Position 3	Position 3

(2) After power on, press "Four-side Embedment" button for the first time and the recycle approach is as follows: four-side simultaneous control of Four-side Embedment → Four-side Embedment 1 → Four-side Embedment 2 → Four-side Embedment 3 → Four-side Embedment 4 → Four-side simultaneous control of Four-side Embedment.

(3) When pressing "Four-side Embedment" button to select air deflector, the selected air deflector flashes. Press "Up-and-down Angle" button to adjust angle of air deflector at the moment.

### 9. Up-and-down SWING Angle:

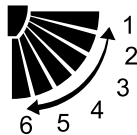

1: Position 1; 2: Position 2; 3: Position 3; 4: Position 4; 5: Position 5; 6: Position 6 (reserved)

Recycle approach: Position 1 → Position 2 → Position 3 → Position 4 → Position 5 → AUTO → Position 1

Free swing: 1 → 2 → 3 → 4 → 5 → 4 → 3 → 2 → 1 is showed circularly.

### 10. Right-and-left SWING Angle (Available for some models):

Recycle approach: 34 showed (Position 1) → 25 showed (Position 2) → 16 showed (Position 3) → 1 showed (Position 4) → 2 showed (Position 5) → 5 showed (Position 6) → 6 showed (Position 7) → Auto swing

Auto swing approach: 1 → 2 → 3 → 4 → 5 → 6 → 5 → 4 → 3 → 2 → 1 are showed circularly.



### 11. HEALTH AIRFLOW (Available for some models):

Press "HEALTH AIRFLOW" button to show  icon on LCD display. Each air deflector of swings on four sides alternates circularly to indicate that the swing rotates to exhaust air. Meanwhile, up-and-down SWING angle shows AUTO SWING. Press it again to cancel HEALTH AIRFLOW.

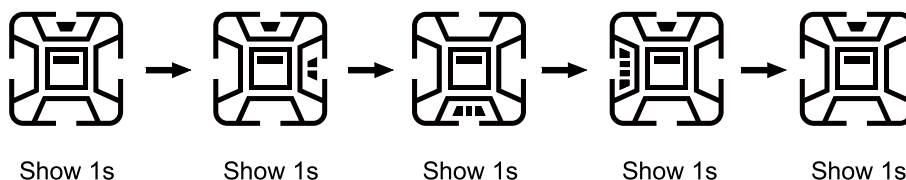





**12. SLEEP:**

- (1) Valid during power on.
- (2) The SLEEP time is fixed to 8 hours and is not adjustable.
- (3) It is invalid in FAN mode. When setting TIMER ON or TIMER ON to TIMER OFF after setting SLEEP function, once the timer setting is successful, the SLEEP function will be cancelled; after setting TIMER ON or TIMER ON to TIMER OFF, the SLEEP function cannot be set. SLEEP function can be set from TIMER OFF to TIMER ON, TIMER OFF and SLEEP function have priority in canceling the opposite side.







**13. HEALTH:**

- (1) During power-on or power-OFF, press "HEALTH" button to display icon  on LCD display, and press "HEALTH" button again to cancel.
- (2) During power-OFF, press "HEALTH" button to enter blowing-in mode, start low wind and HEALTH mode, display icon .
- (3) Switch among modes, and keep HEALTH function.
- (4) If HEALTH function is set, power OFF and then on to stay in HEALTH mode.



**14. ECO:**

- (1) Press ECO button and the display will show .
- (2) ECO is valid under all modes, it is memorized among switch of all modes.
- (3) ECO function power-on or power-OFF is memorized.

**15. Turbo/Quiet:**

- (1) Press button "Turbo" display icon  on remote LCD display, display icon  of fan speed; Press button "Quiet" display icon  on remote LCD display, display icon  of fan speed.
- (2) Turbo and QUIET functions can not exist at the same time, the latter will replace the former.
- (3) If Turbo function is set, press "SLEEP" button to exit turbo, which means that setting SLEEP function while canceling turbo function. At the same time, the icon  disappears and icon  is shown; if QUIET function is set at present, press button "SLEEP" while QUIET function is still kept.
- (4) This function is valid under the mode of COOL or HEAT.
- (5) Turbo/QUIET functions are not memorized among switch of all modes/the state of on or OFF.

**16. IFP:**

- (1) Press "IFP" button, display , IFP function is set, and press "IFP" button again to cancel.
- (2) Press "Follow/Evade" button, display  that expresses following; press it again, display  that expresses evading.  
Press it the third time to cancel.

(3) If follow/evade functions are set, air-out angle will change with position of people, so after setting these functions, Four-side Embedment icons in all sides, up-and-down SWING and left-and-right SWING icons will disappear.

(4) If air conditioner is in the state of HEALTH airflow, follow/evade functions are set, HEALTH airflow function is cancelled, Four-side Embedment, up-and-down SWING and left-and-right SWING icons will disappear.

**17. FRESH (available for some models):**

- (1) FRESH function is valid under the state of on or OFF. When air conditioner is OFF, press "FRESH" button, display icon  on LCD display to enter blowing-in mode and low speed. Press "FRESH" button again, this function is cancelled.
- (2) After FRESH function is set, on or OFF functions are kept.
- (3) After FRESH function is set, mode switch function is kept.

**18. 10°C Heating Function (available for some models) :**

This function is valid only under the mode of HEAT, and it is not memorized under the state of on or OFF.

**19. HEAT (available for some models) :**

- (1) When HEAT mode is chosen  and is displayed on LCD display, pressing "HEAT" button can cancel and set HEAT function.

(2) Auto mode will not start HEAT function automatically, but can set or cancel HEAT function.

#### **20. Timer:**

##### (1) TIMER ON

- Press "TIMER ON" button, character "ON" is flashing, press "+/-" button to adjust, then press "OK" button to confirm, if "OK" button is not pressed within 10 s, TIMER ON function is cancelled.
- If time of TIMER ON is the same as that of clock at present, character "ON" is always flashing and can not be verified, it is necessary to readjust time.
- When the time of TIMER ON is end, the setting time and character "on" disappear.

##### (2) TIMER OFF

- Press "TIMER OFF" button, character "OFF" is flashing, press "+/-" button to adjust, then press "OK" to confirm, if "OK" is not pressed within 10 s, TIMER OFF function is cancelled.
- If time of TIMER ON is the same as that of clock at present, character "OFF" is always flashing and can not be verified, it is necessary to readjust time.
- When the time of TIMER OFF is end, the setting time and character "OFF" disappear.

##### (3) TIMER ON/OFF

- After TIMER ON/OFF is set, remote will automatically judge sequential order of ON/OFF, arrow indicates that the one performed first points to the one performed second.
- After the time of clock performed first is end, corresponding characters of timer "ON/OFF" disappear.
- If time of TIMER ON is the same as that of TIMER OFF, and can not be verified, corresponding character of the latter of setting time is always flashing, it is necessary to readjust time and confirm again.
- If time of TIMER ON/OFF is the same as that of clock at present, and can not be verified, it is necessary to readjust time and confirm again.

(4) After setting timer, display the setting of timer first and then display time all the time, when timer is active, character "ON/OFF" is always displayed.

#### **21. Button +/-:**

- Press button "+/-" time will change in terms of 1 min as unit, pressing and holding the button will change quickly.

#### **22. Clock:**

- Press "Clock" button, "Morning" or "Afternoon" displayed at present are flashing to enter the state of clock adjustment, adjust clock and then press "OK" to confirm.
- It is valid under the state of ON/OFF.

#### **23. LIGHT:**

- No display on remote controller LCD, which is processed by indoor unit.

#### **24. RESET:**

- Perform one power on reset operation when RESET button is pressed.

#### **25. LOCK:**

- Press button Lock, display Lock symbol on LCD display, buttons on remote controller can not be used, press button Lock again to unlock.

#### **26. CODE:**

- Function reserved.

#### **27. INQUIRE**

- Processing by Indoor unit

7.2 Wired controller: YR-E17

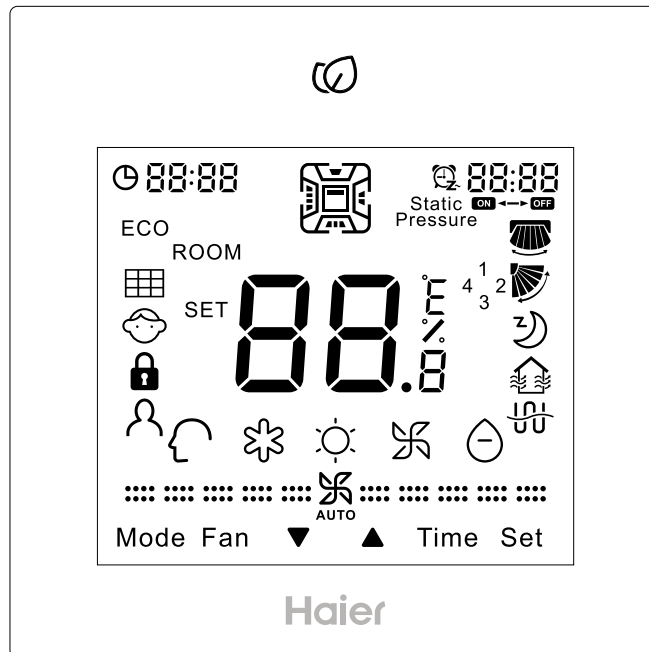

Key

ON/OFF

Adjusting key for temperature, clock, timer, sleeping adjustment, temp. compensation and energy saving;

Inquiring key for detail parameter and malfunction inquiry;

Switching key for function switch.

The adjusting accuracy of temperature is 0.5°C. If energy saving mode is not set, the adjusting range is from 16°C to 30°C. If energy saving mode is set, the lowest temperature limit of cooling/dry and the highest temperature limit of heating are decided by the setting of the chip, the default cooling/dry temperature is 23°C, and the default heating temperature is 26°C.

Note:

- If the dip switch Sw2 is “on”, it displays the ambient temp., as well as when powered off. From power off to power on, mode switching and set temp. adjustment, it flashes to display SET icon and statically displays the set temp.. And then statically displays the ambient temp. and ROOM icon after 3 seconds. In energy saving mode and temp. compensation mode, the adjusting step is 1°C a time.

- If using Fresh Air unit, set temp. cannot be adjusted. If there is no Central/Lock set, the temp. will be fixed at 18°C in cooling and 22°C in heating. The Up/Down key will not display in normal state, but will display and valid in timer setting, function selection, unit shift in malfunction inquiry, parameter shift in parameter check, unit No. setting, sleeping time adjustment, etc.

- If Sw2 is set to be on, meaning ambient temp. display, ambient temp. will be displayed in off state; when in the state of OFF→ON, mode shift, set temp. adjustment, the set temp. will display statically, SET icon flashes and after 3s, ambient temp. and ROOM icon display statically .

24-hour, press once to minus one minute. Keep pressing, minus 2 minutes in 1 second’s pressing, then 10 minutes in 5 seconds. The time will keep decreasing at the pace of 10 minutes a time in 10 seconds. Vice-versa. Press SET to confirm or it will turn back to the previous state automatically in 10s.

## Mode

Press this key to execute mode switch. For detailed information, please refer to mode setting.

Note: If using Fresh Air unit, default 3 modes will circulate from cooling→heating→fan→cooling.

## Fan

Pressing this key, fan speed will be changed in sequence as follows: (Low) → (Medium) → (High)→Auto → (Low)

Note: Auto fan will be changed in sequence as follows:

→ → →

There is no auto fan in fan mode; The fan icon will flash when adjusting the fan speed. It will statically display after the adjustment.

Note: If using Fresh Air unit, fan will be in auto fan and cannot be adjusted. If press FAN key, fan icon and FFFF on the top-right corner will flash, prompting fan speed cannot be adjusted, and will statically display after 3s. Fresh Air unit fan speed will be controlled automatically by indoor unit and wired controller will always display auto fan.

## Time

Timer ON, Timer OFF, Timer ON/OFF.

## Set

Press this key to enter function circulation.

1.Press ▼ to select the functions in sequence as follows:

→ → → → ECO →

2.Press ▲ to select the functions in sequence as follows:

→ ECO → → → →

3. Press Set to confirm function selected. If there is function selected, press Set can cancel this function.

Note: The Left/Right swing is valid only after the dip switch is set, the filter icon is shown only after the filter requires cleaning.

## Icon

88:88	Clock; Parameter setting/inquiry; Malfunction display; Mode setting.
88:88 ON ← OFF	Timer ON/OFF: Sleeping; Parameter setting/inquiry; Malfunction display.
ROOM SET 88.8 TEMP	ROOM/SET temp. and humidity display, each step is 0.5°C . For example, if the temp. is 25°C, it will display 25.0°C instead of 25°C. Humidity display function is reserved.
ECO	Energy Saving, This icon will be displayed only when energy saving function is set.
	Filter Cleaning.
	Child Lock. This icon will be displayed only when child lock function is set.
	Lock/ Central
	Motion Sensing (Reserved).
	Left/Right Swing. This icon is displayed in swing mode; no display without swing mode.
	Up/Down Swing. This icon is displayed in swing mode; no display without swing mode.

	Sleeping. This icon is displayed when setting the sleeping, and left time of sleeping is displayed by 88:88
	Heat Reclaim Ventilation, This icon is displayed when setting the heat reclaim ventilation.
	Electrical Heating. This icon will display when electrical heating is set on DC wired controller.
	Intelligent Mode.
	Cooling Mode.
	Heating Mode.
	Fan Mode.
	Dry Mode.
	Low Fan Speed.
	Medium Fan Speed.
	High Fan Speed.
If the fan speed is set in auto fan, it will change in the following sequence: Low→Medium→High→Low, AUTO icon will display simultaneously.	

## 7.1 Operation

### Dip Switch Interpretation (for AC)

DIP switch	On/Off station	Function	Default setting
Sw1	On	Slave wired controller	Off
	Off	Master wired controller	
Sw2	On	Ambient temp. display on	Off
	Off	Ambient temp. display off	
Sw3	On	Collect ambient temp. from PCB of indoor	Off
	Off	Collect ambient Temp. from wired controller	
Sw4	On	Non-volatile memory invalid	Off
	Off	Non-volatile memory valid	
Sw5	On	Fahrenheit	Off
	Off	Celsius	
Sw6	On	reserved	Off
	Off	reserved	
Sw7	On	Model with Up/Down and Left/Right swing	Off
	Off	Model with Up/Down swing	
Sw8	On	Fresh Air unit	Off
	Off	General unit	

### Difference between the Function of the Master Wired Controller and Slave Wired Controller

Comparison item	Master wired controller	Slave wired controller
Function	All functions are available	1. ON/OFF, Mode, Fan Speed, Temp. Setting, Swing, Energy Saving, Clock function, Heat Reclaim Ventilation function, Mode Setting, Screen Saving and Child Lock are available 2. Cancel the filter cleaning icon 3. Look up the detailed parameter and malfunction code

#### Initialization

(1) The wired controller will display all the icons after powering on or reset, then get into the initializing process. The controller will display in sequence as follows: 88:88 (the top-left corner) → 88:88 (the top-right corner) → 88. → 88:88 (the top-left corner), the green LED flashes all the time until the initialization ends.

(2) If the wired controller can't be communicated with the indoor PCB normally after powering on, the initialization will be finished in 4 minutes, and then the communication malfunction can be checked from the malfunction inquiry function.

#### Screen Saving

(1) In the state of off and non screen saving, keep pressing Time and ▼ for 5s to set screen saving time, which will be shown after the top-right colon 88 statically. Press Up/Down key to adjust screen saving time and press Set key to confirm.

(2) Screen saving time should be 0s(backlight always on), 15s, 30s, 60s, default value is 15s. If it is not the first time of entering, it will display the screen saving time adjusted last time.

(3) In the process of changing screen saving time, press ON/OFF key to quit screen saving time setting function, it will recover to screen saving time before adjustment and start-up the unit.

#### Note:

When controlling Fresh Air unit, the controller main interface will not display Up/Down key in normal state. When in screen saving setting, press Time key first to display Up/Down key at the main interface, and then press together Time and Down key to enter screen saving time setting.

#### Clock Function

(1) 24-hour system is used, and at first time of powering on, it will display default 12:00.

(2) When first powering on wired controller, ☉ 12:00 will be displayed on the wired controller interface, clock time can be adjusted within 10s. At the same time, clock icon ☉ and minute-place of time will flash, meaning the current time can be adjusted. Press Up/Down key to adjust minute-place with flashing of clock icon and no flashing of minute-place. Press Time key to shift to hour-place, and then press Up/Down key to adjust hour-place with flashing of clock icon and no flashing of hour-place. After adjustment, clock icon and hour-place will flash and press Set key to confirm and clock icon and time will display statically.

(3) Press Time key for 5s to enter clock setting function. It will show ☉ 12:00 after first powering on (if not first time of powering on, clock time is the memorized time), with clock icon and minute-place flashing, meaning current time can be adjusted. Press Up/Down key to adjust minute-place with flashing of clock icon and no flashing of minute-place. Press Time key to shift to hour-place, and then press Up/Down key to adjust hour-place with flashing of clock icon and no flashing of hour-place. After adjustment, clock icon and hour-place will flash and press Set key to confirm and clock icon and time will display statically.

(4) Clock time adjustment: when adjusting time, press ▼ one time to reduce one minute/hour while press ▲ one time to add one minute/hour. Keep pressing ▼ or ▲ key to accelerate time adjustment, with 2 times/s change after 1 s, 10 times/s change after 5s. After 10s, it will change by 10 minutes and frequency is 10 times/s.

(5) In the process of time adjustment, if there is no operation for 10s, it will quit and restore previous state.

(6) In the process of time adjustment, press ON/OFF key to quit clock setting function and execute turning on/off operation at the same time.

(7) When setting timer or sleeping function, clock time cannot be adjusted. If press Time key for 5s to enter clock adjustment, clock icon and clock time will flash indicating time cannot be adjusted.

### Timer Function

(1) Timer mode setting: Timer ON, Timer OFF, Timer ON/OFF.

(2) Default: Timer ON is  8:00<sub>ON</sub>, Timer OFF is  12:00<sub>OFF</sub>.

(3) Precision: The time precision is 1 minute. Timer clock is based on the current clock time; the adjustment is the same as clock time.



(4) Screen display: The icon is set to be presented on the top-right of the screen.

(5) Relation to the  (ON/OFF): The ON/OFF button has no affection on timer setting. Under power off state, the Time key is valid.

(6) Timer display:

Timer ON:



Press Time key, it displays default  8:00<sub>ON</sub> for the first time (previous setting will be displayed if there is setting before).

Then hour position and "ON" are flashing. Press   to adjust the timer, minus/add 1 hour a time. Keep pressing to accelerate the adjusting speed. Press Time key a second time and then the minute position and "ON" are flashing. Press Set to confirm the setting, the setting time is displayed and "ON" will not flash. If there is no input for 10s, this setting will be cancelled and the timer will come back to the previous state.

Timer OFF:



Press Time key, it displays default  8:00<sub>ON</sub> for the first time (previous setting will be displayed if there is setting before). Then hour position and "ON" are flashing; Press Time key again, the minute position and "ON" are flashing;





Press Time key again, it displays default  12:00<sub>OFF</sub> for the first time (previous setting will be displayed if there is setting before).

Then the hour position and "OFF" are flashing. Press   to adjust the timer, minus/add 1 hour a time. Keep pressing to accelerate the adjusting speed; Press Time key again, the minute position and "OFF" are flashing. Press Set to confirm the setting, the setting time is displayed and "OFF" will not flash. If there is no input for 10s, this setting will be cancelled and the timer will come back to the previous state.

Timer ON/OFF:

Press Time key, it displays default  8:00<sub>ON</sub> for the first time (previous setting will be displayed if there is setting before).

Then hour position and "ON" are flashing; Press Time key again, the minute position and "ON" are flashing; Press Time key again, it displays default  12:00<sub>OFF</sub> for the first time (previous setting will be displayed if there is setting before). Then the hour position and "OFF" are flashing; Press Time key again, the minute position and "OFF" are flashing; Press Time key again, it displays default  8:00<sub>ON/OFF</sub> for the first time (previous setting will be displayed if there is setting before).

Then the hour position and "ON" are flashing. Press   to adjust the timer, minus/add 1 hour a time. Keep pressing to accelerate the adjusting speed; Press Time key again, the minute position and "ON" are flashing; Press Time key again, it displays default  12:00<sub>OFF</sub> for the first time (previous setting will be displayed if there is setting before). Then the hour and "OFF" are flashing. Press   to adjust the timer, minus/add 1 hour a time. Keep pressing to accelerate the adjusting speed; Press Time key again, the minute position and "OFF" are flashing. The controller will judge the order of timer on and off and use the arrow to show the order. First ON then OFF: ON→OFF; First OFF then ON: ON←OFF. Press Set to confirm the setting. If there is no input for 10s, this setting will be cancelled and the timer will come back to the previous state.

### Timer Setting Cancellation

(1) If there is no Time key related operation for 10s, this setting will be cancelled and the timer will come back to the previous state.

(2) Sequence: Pressing Time once, it displays default  8:00<sub>ON</sub> for the first time (previous setting will be displayed if there is setting before). The hour position and "ON" are flashing;

Pressing for a 2nd time, the minute position and "ON" are flashing;

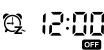

Press for a 3rd time, it displays default  for the first time (previous setting will be displayed if there is setting before). Then the hour position and “OFF” are flashing;

Pressing a 4th time, the minute position and “OFF” are flashing;

Pressing a 5th time, it displays default  for the first time (previous setting will be displayed if there is setting before). Then the hour position and “ON” are flashing;

Pressing a 6th time, the minute position and “ON” are flashing;

Pressing a 7th time, it displays default  for the first time (previous setting will be displayed if there is setting before). Then the hour position and “OFF” are flashing;

Pressing a 8th time, the minute position and “OFF” are flashing;

Pressing a 9th time, cancel the setting.

(3) Relation to other buttons when timer is set.

Press the Mode key or Fan key to exit the current setting, press them again to operate the function accordingly;

Press the  (ON/OFF) key can exit the timer setting and power ON/OFF directly. If there is a timer before, the wired controller will operate by following the previous setting. If not, the wired controller will have no timer operation.

### Swing

(1) If Sw7 is off (default): only Up/Down swing is available.





Press SET key to enter function circulation, Up/Down swing icon flashing, then press SET key again to confirm with swing icon statically displaying. If swing function is set, execute the above operation to cancel.

(2) If Sw7 is on: Up/Down swing and Left/Right swing are available.

Press SET key to enter function circulation, Left/Right swing icon flashing, then press Up/Down key to enter Up/Down swing, with Up/Down swing icon flashing. Press SET key again when swing icon flashing to confirm, with swing icon statically display. If swing function is set, execute the above operation to cancel.

(3) If connecting to the salve wired controller, Sw7 dip code of master and slave wired controllers should be set the same and should match the actual wired controller unit.

### Sleeping

(1) Press Set key to enter function setting, press  to the sleeping icon “” and it will flash, the sleeping time will display by the  which is on the top-right corner. Press Time key to enter sleeping time setting. “OFF” and sleeping icon are flashing. Press  to adjust the sleeping time by 0.5h once, the range of sleeping time is from 0.5h to 72h. After the adjustment, press Set key again to confirm the operation. “OFF” and sleeping icons are statically displayed.

(2) During sleeping icon is flashing, pressing Set key instead of Time key, the wired controller will take the converse operation of previous sleeping state. If there is sleeping set, cancel it; if not, come into the setting operation.

(3) If power off is executed during sleeping, the sleeping function is cancelled at the same time; there is no display when powered on again. It needs to be reset if any requirement.

(4) In sleeping set or modification state, if there is no operation in 10 seconds, it will keep previous state, and the setting or modification is invalid this time.

(5) Under sleeping and timer setting state, it will display setting time respectively; when setting simultaneously, it will display the prior executed time. When timer off is executed first, sleeping function will be cancelled and when sleeping is executed first, then timer off function will be operated after that.



(6) Under function setting state, it will exit function setting state by pressing Mode or Fan key.

(7) If set sleeping time to 1 hour, it will display  on the interface.

(8) Sleeping time and timer on should not be set at the same time.

(9) When setting sleeping function, press ON/OFF key to quit sleeping set and turn off unit.

### Heat Reclaim Ventilation Function

(1) Press Set key to enter function setting, press  to the heat reclaim ventilation icon “” and it will flash, press Set key again to confirm the operation. The above operation can cancel the heat reclaim ventilation function if heat reclaim ventilation function has been set.

(2) After setting heat reclaim ventilation function, it is switched off together with off commend from wired controller. Heat reclaim ventilation function is kept once the unit is switched on again.



(3) After you set heat reclaim ventilation function, change mode of wired controller, heat reclaim ventilation function is kept and heat reclaim ventilation function will be memorized when non-volatile memory valid.

### Energy Saving

(1) Press **Set** key to enter function setting, then press ▼▲ to choose energy saving, press **Set** key again to confirm the operation and display energy saving icon ECO. If energy saving function has been set, the above operation will cancel it.

(2) The energy saving default parameter are 23°C (the lowest temp. limit of cooling and dry mode) and 26°C (the highest temp. limit of heating mode). The temp. adjusting range is 23°C-30°C in cooling and dry mode, the temp. adjusting range is 16°C-26°C in heating mode. If energy saving function is set, the indoor units will run at the default temperature.

Note: Fresh Air unit has no energy saving function.

### Filter Cleaning

When filter cleaning icon  is displayed, the icon will display in function sequence. If filter cleaning icon is flashing, press **Set** key to clear it.

### Mode Setting

(1) In off and non screen saving state, press **Mode** key for 5s, it will display 8 segment on the top-left corner of current mode circulation, default value being 0. Press Up/Down key to shift between 0, 1, 2, 3, then press **Set** key to confirm value. It will follow the altered mode circulation after turning on the unit again.

Corresponding mode of different value.

0-----[Intelligent] [Heating] [Dry] [Cooling] [Fan] 1-----[Heating] [Dry] [Cooling] [Fan]

2-----[Dry] [Cooling] [Fan]

3-----[Heating] [Dry] [Cooling] [Fan]

(2) If modes are reduced and the mode that is set before turning off is not in the newly set mode circulation, the initial mode is fan.

(3) The intersection of mode circulation set by wired controller and indoor unit is valid.

(4) Fresh Air unit can execute mode setting, it will execute the intersection with three modes of Fresh Air unit (cooling/heating/fan mode)

(5) This setting is ground floor setting and will be memorized whether non-volatile memory invalid or valid.

### Malfunction Display

(1) The main interface does not display malfunction.

(2) Under no screen saving state, press **Time** key for 10 seconds to check all indoor units malfunction in the group, but at this time, the interface does not display clock information and timer information. Unit No. is displayed behind the top-left colon; current malfunction is displayed before top-right colon and historical malfunction is behind colon.

(3) Unit No. is displayed in decimal and malfunction is displayed in hexadecimal.

(4) All hexadecimal numbers of malfunction are in capital. But b and d is in small capital in order not to mix with 8.

(5) If there is no current malfunction, "--" is displayed before the right colon; if there is no historical malfunction, "--" is displayed behind the right colon.

(6) Press **Time** key to quit malfunction check state. The clock information and timer information are displayed.

(7) Malfunction records clearance: Keep pressing **Time** key for 10 seconds, malfunction is displayed. Then press **Time** key again for 5 seconds to clear current and historical malfunction of all the units.

(8) Press ▼▲ to choose unit No..

### Child Lock

(1) Child lock function can be used to prevent false operation. All of keys are locked after pressing **Set** and ▼ together for 5 seconds. child lock icon  will display on the interface. All of settings will exit and keep the previous state. All of keys are invalid including "ON/OFF".

(2) The screen will unlock after pressing **Set** and ▼ together for 5 seconds, child lock icon will disappear and all keys are available.

Note:

When controlling Fresh Air unit, the controller main interface will not display Up/Down key in normal state. When in

child lock setting, press Time key first to display Up/Down key at the main interface, and then press Set and Down key together for 5 seconds to enter child lock setting. After setting child lock, Up/Down key will keep displaying for the convenience of cancellation of child lock.

### Parameter Inquiry

(1) Keep pressing Set for 5 seconds to enter parameter inquiry. Unit No. is displayed on 88 area of clock while data type is displayed on 88 area of timer. Unit No. is displayed on the first two "88" fields of clock while data type is displayed on the first two "88" fields of timer. The data type includes A, b, C, d, E and F. The current data is displayed behind date type. For example, ambient temp. of 00 unit is 16 degree, then "00 A 16" is displayed. Press ▼▲ to choose different type of data from A, b, C, d, E and F.

Data	Type meaning	System
A	Indoor sensor Tai temp.	Actual value, decimal sys.
b	Indoor sensor Tc1 temp.	Actual value, decimal sys.
C	Indoor sensor Tc2 temp.	Actual value, decimal sys.
d	Indoor unit PMV opening/2	Actual value, decimal sys.
E	Indoor unit address	Actual value, hexadecimal sys.
F	Indoor unit central address	Actual value, hexadecimal sys.

(2) In parameter inquiry state, press Time key to change the unit No. address in the group.

(3) In parameter inquiry state, press the Set key again or have no operation for 10 seconds to exit.

(4) In parameter inquiry state, press Mode or Fan can exit the parameter inquiry and press above keys again, their corresponding functions will work.

(5) In parameter inquiry state, press "ON/OFF", it will exit the current state directly and then turn on/off.

### Unit No. Setting

(1) Entering: Press Set key for 10 seconds to enter unit No. setting/ inquiring.

(2) Setting is available when the communication address between indoor and outdoor unit is flashing if the indoor unit's dip switch can set the address, then use ▼▲ to adjust within the range of 0-3F. If the indoor dip switch cannot set the address, the communication address between indoor and outdoor unit is static, which can only be inquired.

(3) Wired controller's address is displayed before the colon of clock on the top-left corner, ranging from 0 to 15 and displayed in decimal system.

(4) The communication address between indoor and outdoor unit is displayed on the top-left corner. The default value is the current unit's address, selecting other indoor units by the ▼▲.

(5) Central address is displayed on top-right corner which cannot be edited.

(6) Press Set key to confirm and exit the setting after changing the communication address of indoor unit. If press other keys or no operation in 10 seconds, it will automatically exit and keep previous setting. If press Mode or Fan key, exit and the current setting is invalid. If press "ON/OFF", turn on/off the unit directly and the current setting is invalid.

### Static Pressure Grade Inquiry and Adjustment Function

(1) In the state of ON and non screen saving state, press Fan + Set keys for 5s to enter static pressure grade adjustment state with static pressure icon flashing and current static pressure grade statically displaying. Press ▼▲ key to change static pressure grade, then press Set key to confirm.

(2) The unit No. will display by two 8 segments after colon on the top-left corner, and static pressure grade will display by two 8 segments after colon on the top-right corner. Press Time key to shift unit No..

(3) Unit No. will show decimally from 00-15. Static pressure will be shown decimally from 01-04.

(4) In query and adjustment state, if there is no screen saving, press ON/OFF key to quit current state and turning on/off unit, with changed values not being saved.

(5) Static pressure is the inquired value with non-volatile memory invalid.

### Communication with Central Controller

(1) The controller displays  to show central control mode after receiving central control signal from indoor unit;

(2) When  statically displays, all keys except "ON/OFF" of wired controller are invalid. central icon will disappear if no central control signal from indoor unit.

(3) When receiving locking signal from indoor unit,  statically display, all keys are invalid.

- (4) In central or lock state, screen saving is valid; press any key to wake up screen.
- (5) In central or lock state, malfunction inquiry, indoor unit parameter inquiry and child lock are valid.

#### **Energy Saving Parameter Setting**

- (1) Under cooling mode 30°C, keep pressing F<sub>AN</sub> key for 5 seconds to set energy saving parameter in cooling mode. This cooling energy saving parameter is flashing behind top-left colon. The default value is 23°C. This lowest target cooling temperature can be adjusted by ▼▲. After setting, press Set key to confirm and exit.
- (2) Under heating mode 16°C, keep pressing F<sub>AN</sub> key for 5 seconds to set energy saving parameter in heating mode. This heating energy saving parameter is flashing behind top-right colon. The default value is 26°C. This highest target heating temperature can be adjusted by ▼▲. After setting, press Set key to confirm and exit.
- (3) Energy saving parameter will be valid after energy saving icon ECO displays.

#### **Non-volatile Memory**

- (1) Set valid or invalid non- volatile memory through dip switch Sw4.
- (2) Info memorized: Mode, Fan Speed, Temp. Setting, Swing State, Heat Reclaim Ventilation function.
- (3) If timer or sleeping is set, it will be in OFF state after electrified again; it will memorize all the state before power failure except ON/OFF state.
- (4) For easy maintenance, no matter non-volatile memory is valid or invalid, malfunction record will be remembered.

#### **Communication Malfunction of Wired Controller**

If there is no communication between wired controller and indoor unit for 4 minutes, it will display error code "07" when checking malfunction.

#### **Sensor Malfunction**

If the dip switch is set to collect ambient Temp. from wired controller and the sensor can't work normally, it will display error code "01" when checking malfunction.

#### **Temp. Compensation Setting**

- (1) In OFF state, keep pressing F<sub>AN</sub> key for 5 seconds, the current temp. compensation value is displayed on the top-right of the screen and flashes. "00" is the default value.
- (2) When in celsius system, ambient compensation value is -04~+04, while in fahrenheit system, ambient compensation value being -07~+07. The temp. compensation value can be adjusted by pressing ▼▲.
- (3) After adjustment, press Set key to confirm the setting.
- (4) The compensation value is used for ambient temp..
- (5) The compensation value is valid only in the state of collecting ambient temp. of wired controller.

#### **Forced Cooling/ Heating**

- (1) Powered off in cooling mode, keep pressing "ON/OFF" key for 10 seconds, it will enter into the forced cooling function, and the cooling mode icon will be displayed on the interface. "LL" is flashing in the temp. area at the same time. Press "ON/OFF" key to power off and exit forced cooling.
- (2) Powered off in heating mode, keep pressing "ON/OFF" key for 10 seconds, it will enter into the forced heating function, and the heating mode icon will be displayed on the interface, "HH" is flashing in the temp. area at the same time. Press "ON/OFF" key to power off and exit forced heating.
- (3) All the keys are invalid except "ON/OFF" key under forced cooling/heating mode, which can be cancelled by powering off manually or receiving "trial operation" finished order from the communication. The former one can operate power off directly while the later one will make the controller do by following the order.

## 7.2 Wired Controller Wiring Instruction

### Wiring Connections of Wire Controller

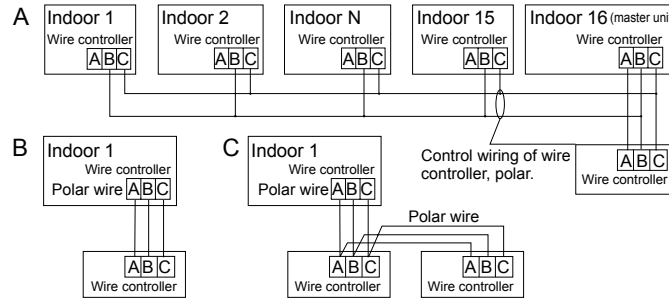

There are three methods to connect wired controller with the indoor units

- One wired controller can control max. up to 16 sets of indoor units, and 3 pieces of polar wire must connect the wire controller and the master unit (the indoor unit connected with wire controller directly), the others connect with the master unit through 2 pieces of polar wire.
- One wire controller controls one indoor unit, and the indoor unit connects with the wire controller through 3 pieces of polar wire.
- Two wired controllers control one indoor unit. The wired controller connected with indoor unit is called master one, the other is called slave one. Master wired controller and indoor unit; master and slave wire controllers are all connected through 3 pieces of polar wire.

### Communication wiring

Communication wiring length (m)	Dimensions of wiring
< 100	0.3mm <sup>2</sup> x3-core shielded wire
≥100 and <200	0.5mm <sup>2</sup> x3-core shielded wire
≥200 and <300	0.75mm <sup>2</sup> x3-core shielded wire
≥300 and <400	1.25mm <sup>2</sup> x3-core shielded wire
≥400 and <500	2mm <sup>2</sup> x3-core shielded wire

\*One side of the shielded sheet of communication wire must be earthed.

- First, put communication wire through the hole in the back cover.

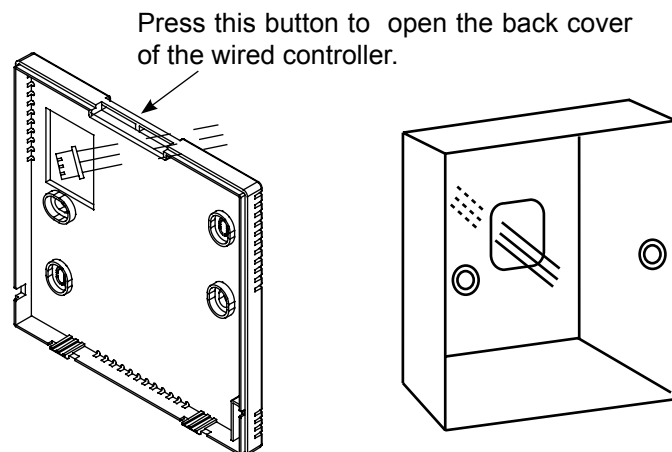

2. Fix back cover to the holder. After that, connect communication wire to CON1 port of wired controller. Finally put the front cover of wired controller to back cover to complete the installation.

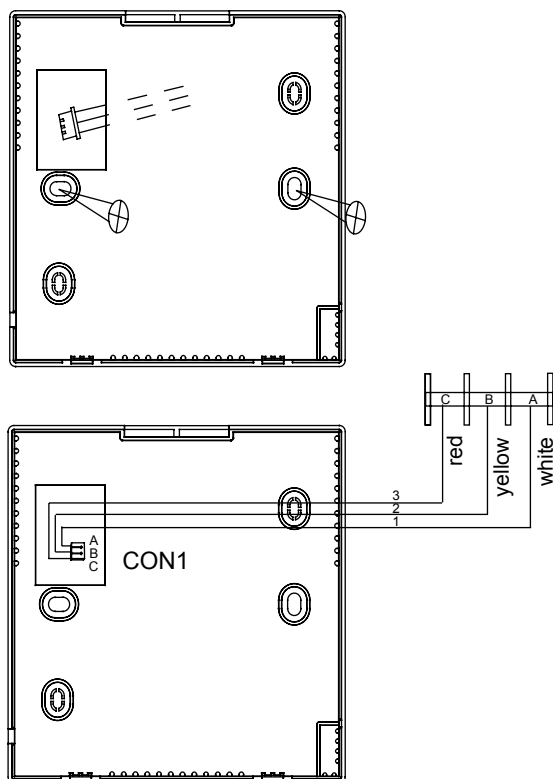

## Appendix Sensor Characteristic

Model	Sensor name	Part code	Charcteristic
ABH071H1ERG ABH090H1ERG ABH105H1ERG ABH125K1ERG ABH140K1ERG	Ambient temp. sensor	001A3900159	R25=23KΩ±3% B25/50=4200K±3%
ADH071M1ERG ADH090M1ERG ADH105M1ERG ADH125M1ERG ADH140M1ERG	Indoor coil temp. sensor	0010401922	R25=10KΩ±3% B25/50=3700K±3%
1UH071N1ERG 1UH090N1ERG 1UH105N1ERG 1UH125P1ERG 1UH125P1ERK 1UH140P1ERG 1UH140P1ERK	Defrosting temp. sensor	0010450194	R25=10KΩ±3% B25/50=3700K±3%
	Ambient temp. sensor	0010450192	R25=10KΩ±3% B25/50=3700K±3%
	Discharging temp. sensor	0010451303	R80=50KΩ±3% B25/50=4450K±4%
	Outdoor coil temp. sensor	0010451329	R25=10KΩ±3% B25/50=3700K±3%
	Sunction temp. sensor	0010451307	R25=10KΩ±3% B25/50=3700K±4%



## Haier Commercial Air Condition

ADDRESS: No.1 Haier Road, Hi-tech Zone, Qingdao 266101 P.R.China

Web: [Http://www.haier.com](http://www.haier.com)