

SPLIT TYPE ROOM AIR CONDITIONER OPERATION MANUAL



HSU-09HEG03/R2(DB)

HSU-12HEG03/R2(DB)

HSU-18HEG03/R2(DB)

HSU-24HEG03/R2(DB)

Contents

PARTS AND FUNCTIONS	2
OPERATION	3
MAINTENANCE	6
CAUTIONS	7
TROUBLE SHOOTING	8

Please read this operation manual before using the air conditioner.

Keep this operation manual for future reference.

Parts and functions

Indoor Unit

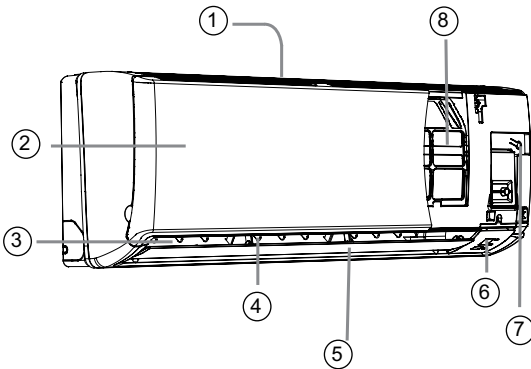

- ① Inlet
- ② Inlet grille
- ③ Outlet
- ④ Vertical blade (adjust left and right air flow)
- ⑤ Horizontal flap (adjust up and down air flow. Don't adjust manually.)
- ⑥ Display board
- ⑦ Emergency Switch
- ⑧ Air Purifying Filter (inside)

The picture above is for reference, products may differ slightly from the image shown.

Outdoor Unit

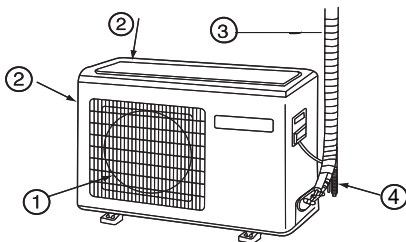

- ① Outlet
- ② Inlet
- ③ Connecting piping and electrical wiring
- ④ drain hose

The picture above is for reference only. Products may differ slightly from the image shown.

Hint:
Remove the batteries if the product won't be in use for a long period. If there is any display after the batteries are removed, just press the reset key.

Remote controller

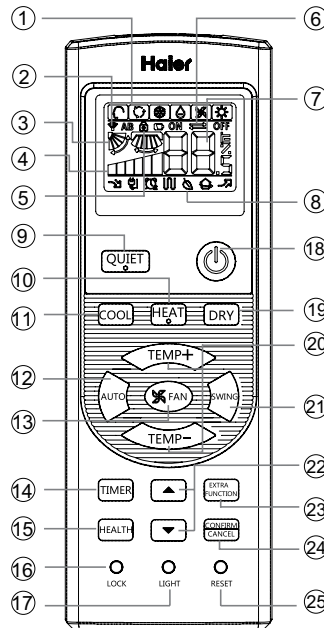

- 9. QUIET button
- 10. HEAT button
- 11. COOL button
- 12. AUTO button
- 13. FAN speed button
- 14. TIMER button
- 15. HEALTH button
- 16. LOCK button
Used to lock buttons and LCD display.
- 17. LIGHT button
Turns the indoor LED display board on and off.
- 18. POWER ON/OFF button
- 19. DRY button
- 20. TEMP button
- 21. SWING button
- 22. HOUR button
- 23. EXTRA FUNCTION button
Functions:
 - FAN only mode
 - Airflow position 1/2
 - Airflow position 4/5
 - Restore original louver position
 - Right / Left airflow (not used)
 - A-B remote selection
 - Heating mode
 - SLEEP mode
 - Electrical element heating (not used)
 - Refresh air (not used)
 - POWER operation
 - Fahrenheit / Celsius display
- 24. CONFIRM/CANCEL button
Function: Set and cancel the timer and other additional functions (press within 5 seconds to confirm).
- 25. RESET button
When the remote controller appears abnormal, use a sharp pointed article to press this button to reset the remote.

1. Mode display

Operation mode	AUTO	COOL	DRY	HEAT	FAN
Remote controller					

2. Signal sending display

3. SWING display

4. FAN SPEED display

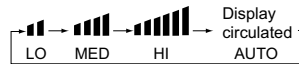

5. LOCK display

6. TIMER OFF display TIMER ON display

7. TEMP display

8. Additional functions display

Operation mode	QUIET	SLEEP	Supplemented electrical heating (not used)	HEALTH	POWER
Remote controller					

HEALTH function is not available for some units.

Loading of the battery

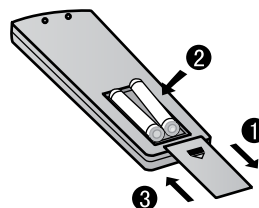

1. Remove the battery cover;
2. Load the batteries as illustrated. Use "AAA" batteries, resetting key (cylinder);
3. Be sure that the batteries are in line with the + / - ;
4. Load the battery, then replace the cover.

Note:

- The distance between the signal transmission head and the receiver hole should be less than 7m. Any obstacles between the transmission head and receiver hole may block the signal.
- If an electric fluorescent light or wireless telephone is installed in the room, it may interrupt the signal, so the distance between the controller and indoor unit should be shorter.
- If the display is full or unclear, charge the batteries.
- If the remote controller doesn't run normally, remove the batteries and reload several minutes later.
- If two units are installed in the same room, both units can be operated by one remote controller. You can also make a dedicated remote controller for each unit. The remote controller and unit are by default set as ID codes "A", shown on the top left hand side of the display. To change ID for the unit and remote, turn the power on and press the **EXTRA FUNCTION** button repeatedly until "AB" is displayed – the "B" should be flashing. Press **CONFIRM/CANCEL** button to confirm. "B" should now be shown on the display.

Operation

Basic Operation

Remote controller

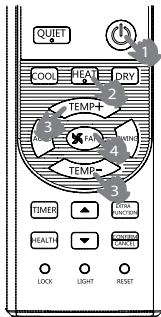

- Unit start**
Press ON/OFF on the remote controller to start the unit.
- Select operation mode**
 AUTO button: Automatic selection of heating or cooling
 COOL button: Refrigerated cooling mode
 HEAT button: Reverse cycle heating mode
 DRY button: Dehumidify mode
 FAN only mode: Air circulation only, no heating or cooling

Operation Mode	Remote Controller	Note
AUTO		In AUTO mode the air conditioner will automatically select Cool or Heat operation according to the room temperature. When the FAN speed is set to AUTO, the air conditioner automatically adjusts the fan speed according to the room temperature. Temperature settings can not be adjusted
COOL		In COOL mode, cool to cold air will blow out after a short delay. When the FAN is set to AUTO, the air conditioner automatically adjusts the fan speed according to room temperature.
HEAT		In HEAT mode, warm air will blow out after a short delay due to the cold-draft prevention function. When FAN is set to AUTO, the air conditioner automatically adjusts the fan speed according to room temperature.
DRY		In DRY mode, when the room temperature becomes lower than the temperature setting +2°C, unit will run intermittently at LOW speed regardless of the FAN setting.
FAN		Press extra function and confirm/cancel button to select FAN mode. In FAN operation mode, the unit will not operate in COOL or HEAT mode, but only in FAN mode. AUTO is not available in FAN mode, the temperature setting is disabled and the sleep operation is not available.

Note: The cool or warm air will be regulated by the room temperature and the temperature you have selected on the remote control. Cool or warm air will cease to blow out once the room has reached your selected temperature. During heating, the unit may go into a "De-ice" – this is normal and the unit should be left operating during this period. Steam may be visible at the outdoor unit as it automatically removes any ice build up. Once this function is complete your unit will revert back to heating.

- Select temperature setting**
Press TEMP+ / TEMP- button

TEMP+ Every time the button is pressed, the temperature setting will increase by 1°C. If you hold the button down it will increase rapidly.

TEMP- Every time the button is pressed, the temperature setting will decrease by 1°C. If you hold the button down it will decrease rapidly.

Select your desired temperature (16-30°C).

Note: When AUTO mode is selected, the temperature setting can not be adjusted.

- Fan speed selection**
Press FAN button. Each time you press the button, the fan speed changes as shown in the diagram

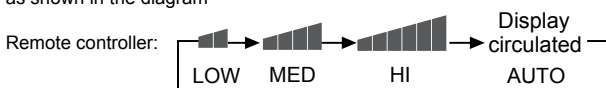

When FAN is set to AUTO, the air conditioner automatically adjusts the fan speed according to the room temperature.

Airflow Direction Adjustment

- Airflow direction display**
The airflow positions are shown on the remote controller display as below:

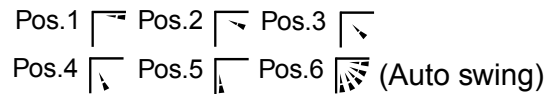

- To set airflow direction, press the **EXTRA FUNCTION** button to enter additional options. Press this button to cycle between the three locations shown below. Choose the swing location that you need, then press the **CONFIRM/CANCEL** button to confirm.



Note:
Do not direct the flap by hand, otherwise the grille will run incorrectly. Damage to this flap due to manual adjustment is not covered by warranty. If the grille does not run correctly, stop for a minute and then restart, using the remote controller to adjust it.

Note:

- After setting the airflow direction, the position grille is fixed.
- For heating, it is better to select the mode
- For cooling, it is better to select the mode.
- In cooling and dry modes, when using the air conditioner for a long time in high air humidity, condensate water may collect on the grille.
- AUTO swing**
Press SWING button to cycle the louvers between Pos.1 and 5. Press again to stop cycling.
- Left and right air flow adjustment (manual)**
Move the vertical blade using the knob on the air conditioner to adjust left and right, as shown in the diagram.

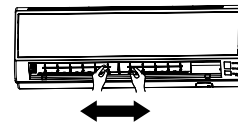

Caution:

- When adjusting the flap by hand, turn the unit off first.
- When humidity is high, condensate water might drain through the air outlet if all vertical louvers are adjusted to the left or right.
- It is advisable not to keep the horizontal flap in the downward position for a long time in COOL or DRY mode, or condensate water might collect.



Note:

When restarting after turning off remotely, the remote controller will automatically memorize the previous set position.

Operation

Sleep Operation

Press  button to enter additional options.

When display cycles to ,  will flash.

Then press  to enter sleep function.



1. Operation Mode

In COOL, DRY mode

1 hour after SLEEP mode starts, the temperature will become 1°C higher than the temperature setting. After another hour the temperature rises by another 1°C. The unit will run for a further 6 hours. The temperature is higher than the temperature setting, so that the room temperature won't be too cold for you to sleep.

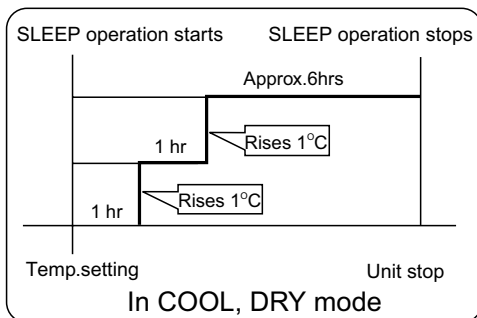

2. In HEAT mode

1 hour after SLEEP mode starts, the temperature will become 2°C lower than the temperature setting. After another hour, the temperature decreases by a further 2°C. After another 3 hours, the temperature will rise by another 1°C. The unit will run for a further 3 hours. The temperature is lower than the temperature setting, so that the room temperature won't be too hot for you to sleep.

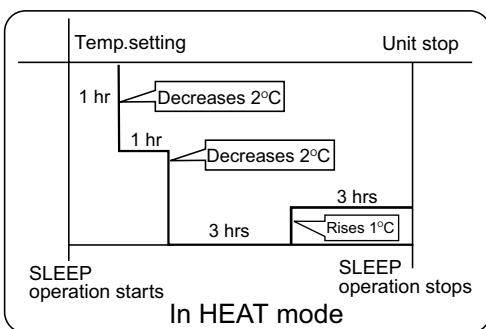

3. In AUTO mode

The unit operates in the corresponding sleep mode for the automatically selected operation mode.

4. In FAN mode

The SLEEP function does not operate in FAN mode.

5. Set the fan speed change when sleeping

If the fan speed is high or medium, you can set it to lower the fan speed after you go to sleep. If it is already set at low fan speed, it is unchanged.







Note

When the TIMER function is set, the sleeping function can't be set up. After the sleep function is set up, if you reset the TIMER function, the sleep function will be cancelled.

POWER/QUIET Operation

1. POWER Operation

When you need rapid heating or cooling, you can use this function.

Press the  button to enter additional options. Press the  repeatedly until  displays. When the display cycles to ,  will flash. Then press , to confirm.

Repeat the process above to cancel.

2. QUIET Operation

You can use this function when silence is needed for rest or reading.

Press the QUIET button and the remote controller will show .

Press the QUIET button again and the quiet function will be cancelled.

Note:

During POWER operation, in rapid HEAT or COOL mode, the room may show uneven temperature distribution. Extended use of the QUIET function will provide complete and efficient cooling of your room.

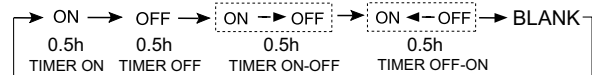

Timer On-Off Operation

- After unit starts, select your desired operation mode.
- Press the TIMER button to change to TIMER mode. Every time the button is pressed, the display changes as follows:



Remote controller:

Then select your desired TIMER mode (TIMER ON or TIMER OFF or TIMER ON-OFF). "ON" or "OFF" will flash.

- Press  /  button to set the time.
 - ▲ Press the button for each time, setting time in the first 12 hours increased by 0.5 hour every time and after 12 hours, increased by 1 hour every time.
 - ▼ Press the button for each time, setting time in the first 12 hours decreased by 0.5 hour every time and after 12 hours, decreased by 1 hour every time. It can be adjusted within 24 hours.
- Confirm timer setting
After adjusting the time, press the  button and confirm the time. The ON or OFF button will not flash any more.
- Cancel timer setting
Press the timer button repeatedly until the time display does not show.

Hints:

After replacing batteries or a power failure, the time setting should be reset.

European regulations conformity for the models

CE

All the products are in conformity with the following European provision:

- Low Voltage Directive 2006/95/EC
- Electromagnetic Compatibility 2004/108/EC

ROHS

The products are fulfilled with the requirements in the directive 2002/95/EEC of the European parliament and of council on the Restriction of the use of Certain Hazardous Substances in Electrical and Electronic Equipment (EU RoHS Directive)

WEEE

In accordance with the directive 2002/96/CE of the European parliament, we herewith inform the consumer about the disposal requirements of the electrical and electronic products.

DISPOSAL REQUIREMENTS:

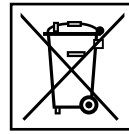

Your air conditioning product is marked with this symbol. This means that electrical and electronic products shall not be mixed with unsorted household waste. Do not try to dismantle the system yourself: the dismantling of the air conditioning system, treatment of the refrigerant, of oil and of other parts must be done by a qualified installer in accordance with relevant local and national legislation. Air conditioners must be treated at a specialized treatment facility for reuse, recycling and recovery. By ensuring this product is disposed of correctly, you will help to prevent potential negative consequences for the environment and human health. Please contact the installer or local authority for more information. The battery must be removed from the remote controller and disposed of separately in accordance with relevant local and national legislation.

Important information regarding the refrigerant used

This product contains fluorinated greenhouse gases covered by the Kyoto Protocol. Do not vent into the atmosphere.

Refrigerant type: R410A

GWP* value: 1975

GWP = global warming potential

Please fill in with indelible ink,

- 1 the factory refrigerant charge of the product
- 2 the additional refrigerant amount charged in the field and
- 1+2 the total refrigerant charge on the refrigerant charge label supplied with the product.

The filled out label must be adhered in the proximity of the product charging port (e.g. onto the inside of the stop valve cover).

Contains fluorinated greenhouse gases covered by the Kyoto Protocol		A
R410A	1= _____ kg	B
	2= _____ kg	C
	1+2= _____ kg	D
F	E	

A contains fluorinated greenhouse gases covered by the Kyoto Protocol

B factory refrigerant charge of the product: see unit name plate

C additional refrigerant amount charged in the field

D total refrigerant charge

E outdoor unit

F refrigerant cylinder and manifold for charging

Emergency operation and test operation

Emergency Operation:

- Use this only when the remote controller is defective or lost. The air conditioner can run automatically for a while.
- When the emergency operation switch is pressed, the "Pi" sound is heard once, which means emergency operation has started.
- When power switch is turned on for the first time and emergency operation starts, the unit will run automatically in the following modes:

Room temperature	Designated temperature	Timer mode	Fan speed	Operation mode
Above 23°C	26°C	No	AUTO	COOL
Below 23°C	23°C	No	AUTO	HEAT

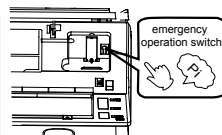

- It is impossible to change the settings of temperature fan speed, or to operate in timer or dry mode.

Test operation:

The test operation switch is the same as the emergency switch.

- Use this switch in the test operation when the room temperature is below 16°C. Do not use it during normal operation.
- Continue to press the test operation switch for more than 5 seconds. After you hear the "Pi" sound twice, release your finger from the switch: the cooling operation starts with the air flow speed "Hi".
- Under this operation mode, the fan motor of indoor unit will run in high speed.

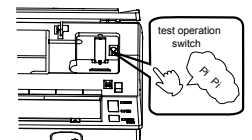

Maintenance

For Efficient Use of The Air Conditioner

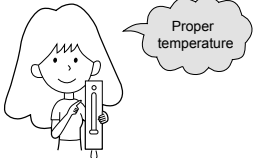
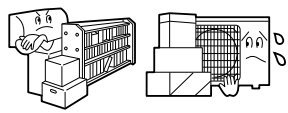
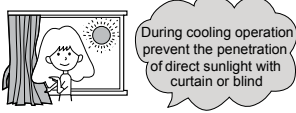
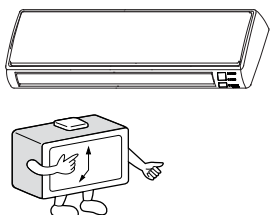
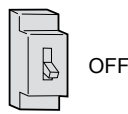
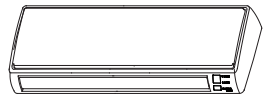
<p>Setting of proper room temperature</p> 	<p>Do not block the air inlet or outlet</p> 
<p>Close doors and windows during operation</p> 	<p>Use the timer effectively</p> 
<p>If the unit is not to be used for a long time, turn off the main power supply switch.</p> 	<p>Use the louvers effectively</p> 

Remote Controller



Do not use water, wipe the controller with a dry cloth. Do not use glass cleaner or chemical cloth.

Indoor Body



Wipe the air conditioner by using a soft and dry cloth. For serious stains, use a neutral detergent diluted with water. Wring the water out of the cloth before wiping, then wipe off the detergent completely.

Do not use the following for cleaning



Spirits, benzene, thinner or cleanser may damage the coating of the unit.



Hot water over 40°C (104°F) may cause discoloring or deformation.

Air Filter cleaning

1. Open the inlet grille by pulling it upward.

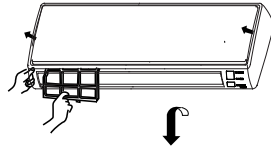

2. Remove the filters (left and right side). Push up the filter's centre tab slightly until it is released from the stopper, and remove the filter downward.

3. Clean the filters. Use a vacuum cleaner to remove dust, or wash the filter with water. After washing, dry the filter completely in the shade.

4. Attach the filters. Attach the filter correctly so that the "FRONT" indication is facing to the front. Make sure that the filter is completely fixed behind the stopper. If the right and left filters are not attached correctly, that may cause defects.

5. Close the inlet grille.

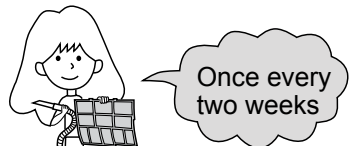

Maintenance of Air Purifying Filters

1. **Open the Inlet Grille**
Hold the front panel by the tabs on both sides and lift it until it stops with a click.



2. **Detach the standard air filters**
Slide the knob slightly upward to release the filter, then withdraw it.

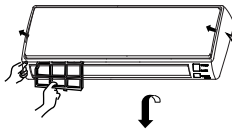

Detach old Air Purifying Filter



3. **Attach Air Purifying Filters**
Put air purifying filters into the right and left filter frames (one in each).

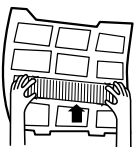

4. **Attach the standard air filter**
(Necessary installation)

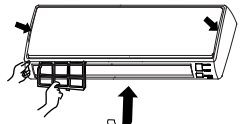

Attention:
The white side of the photocatalyst air purifying filter faces outside, and the black side faces the unit. The green side of the bacteria-inhibiting air purifying filter faces outside, and the white side faces the unit.

5. **Close the Inlet Grille**
Close the grille securely.

Note:

- The photocatalyst air purifying filter will need to be 'recharged' from time to time. Under normal household use, it will need to be recharged every 6 months. Place the filter in sunlight for 1 hour to recharge it. Do not wash or try to clean.
- The bacteria-inhibiting filter can be used for a long time without need for replacement. However, you should remove dust frequently by using a vacuum cleaner or tapping the filters lightly. This will ensure good performance.
- Please keep the bacteria-inhibiting filter in cool and dry conditions. Avoid leaving it in direct sunshine, or its ability to sterilise will be reduced.

Cautions

⚠ WARNING

Please call Sales/Service Shop for the Installation.

Do not attempt to install the air conditioner by yourself because improper works may cause electric shock, fire, water leakage.

This appliance must be installed only by suitably qualified technicians complying with this installation manual and all local, state and national codes.

⚠ CAUTION

Do not use for the purpose of storage of food, art work, precise equipment, breeding, or cultivation.



PROHIBITION

Take fresh air occasionally especially when gas appliance is running at the same time.



STRICT ENFORCEMENT

Do not operate the switch with wet hand.



PROHIBITION

Do not install the unit near a fireplace or other heating apparatus.



PROHIBITION

Check good condition of the installation stand.

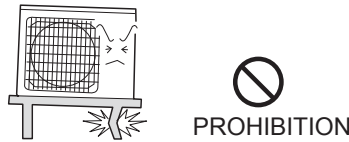

PROHIBITION

Do not pour water onto the unit for cleaning.



PROHIBITION

Do not place animals or plants in the direct path of the air flow.



PROHIBITION

Do not place any objects on or climb on the unit.



PROHIBITION

Do not place flower vase or water containers on the top of the unit.



PROHIBITION

CAUTION

- Do not obstruct or cover the ventilation grille of the air conditioner. Do not put fingers or any other things into the inlet/outlet and swing louver.
- Do not allow children to play with the air conditioner, or to sit on the outdoor unit.

Specifications

- The refrigerating circuit is leak-proof.

The machine is adaptive in following situation





- Applicable ambient temperature range:

Cooling	Indoor	Maximum: D.B / W.B	32°C / 23°C
		Minimum: D.B / W.B	21°C / 15°C
	Outdoor	Maximum: D.B / W.B	43°C / 26°C
		Minimum: D.B	18°C
Heating	Indoor	Maximum: D.B	27°C
		Minimum: D.B	15°C
	Outdoor	Maximum: D.B / W.B	24°C / 18°C
		Minimum: D.B / W.B	-7°C / -8°C

- If the power supply cord is damaged, it must be replaced by the manufacturer or its service agent or a similarly qualified person.
- If the fuse of indoor unit on PC board is broken, please change it with the type of T. 3.15A/ 250V. If the fuse of outdoor unit is broken, change it with the type of T.25A/250V. The fuse is must be replaced by the manufacturer or its service agent or a similar qualified person.
- The wiring method should be in line with the national wiring standard.
- The waste battery should be disposed properly.
- This appliance is not intended for use by persons (including children) with reduced physical, sensory or mental capabilities, or lack of experience and knowledge, unless they have been given supervision or instruction concerning use of appliance by a person responsible for their safety.
- Children should be supervised to ensure that they do not play with the appliance.
- If the cooler is not to be used for an extended period, please turn off the A/C first then, at least 30 seconds later, cut off the power.

Trouble shooting

Before asking for service, check the following first.

	Phenomenon	Cause or check points
Normal Performance inspection	The system does not restart immediately. 	<ul style="list-style-type: none"> When the unit is stopped or the operating mode changes, it won't restart immediately until 3 minutes have elapsed, to protect the system.
	Noise is heard 	<ul style="list-style-type: none"> During unit operation or at stop, a swishing or gurgling noise may be heard. At first 2-3 minutes after unit start, this noise is more noticeable. (This noise is generated by refrigerant flowing in the system.) During unit operation, a cracking noise may be heard. This noise is generated by the casing expanding or shrinking because of temperature changes. Should there be a loud noise from air flow in the unit operation, the air filter may be too dirty. Normally it should be cleaned every 15 days.
	Smells are generated.	<ul style="list-style-type: none"> This is because the system circulates smells from the interior air such as the smell of furniture, paint, cigarettes.
	Mist or steam are blown out. 	<ul style="list-style-type: none"> During COOL or DRY operation, indoor unit may blow out mist. This is due to the sudden cooling of indoor air.
	In dry mode, fan speed can't be changed.	<ul style="list-style-type: none"> In DRY mode, when room temperature becomes lower than temperature setting +2°C, unit will run intermittently at LOW speed regardless of FAN setting.
Multiple check		<ul style="list-style-type: none"> The circuit breaker switch is "ON", but not "off"? Is there a power failure? Is fuse blown out?
	Poor cooling 	<ul style="list-style-type: none"> Is the air filter dirty? Normally it should be cleaned every 15 days. Are there any obstacles before inlet and outlet? Is temperature set correctly? Are there some doors or windows left open? Is there any direct sunlight through the window during the cooling operation? (Use curtain) Are there too many heat sources or too many people in the room during cooling operation?



Seeley International Pty Ltd
ABN 23 054 687 035

112 O'Sullivan Beach Road
Lonsdale, South Australia 5160

Phone (08) 8328 3850
Fax (08) 8328 3951

Email marketing@seeleyinternational.com
Web seeleyinternational.com

Haier service call 1300 526 477