

SPLIT WALL-MOUNTED AIR CONDITIONER

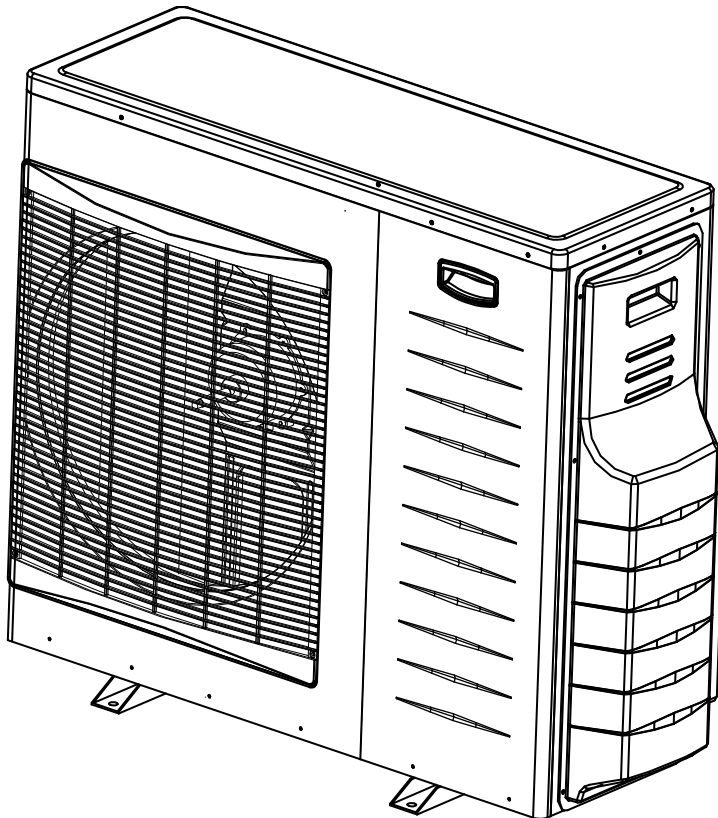
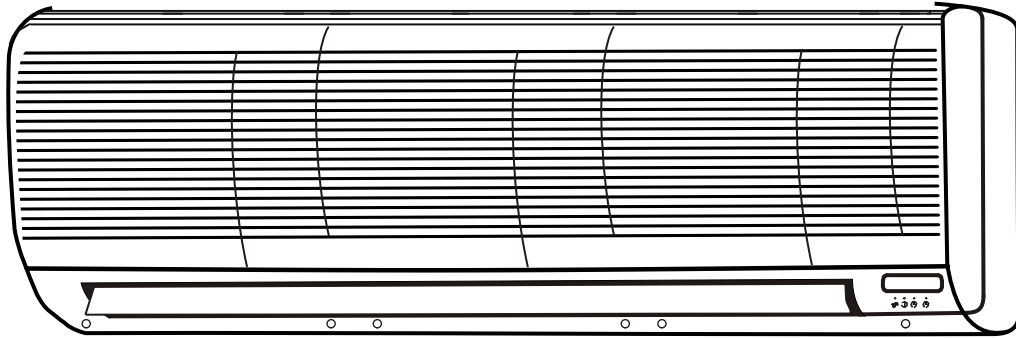

MODELS: XLM36IRCB / GC34RCC

PROGRAMING OPERATION MANUAL & INSTALLATION INSTRUCTIONS

CONTENTS

INTRODUCTION	1
SYSTEM DESCRIPTION	2
MODES OF OPERATION, FUNCTIONS AND FEATURES	4
USE OF WIRELESS REMOTE CONTROL	6
ON-UNIT INDICATORS AND CONTROLS	7
REMOTE CONTROL	9
OPERATION PROCEDURE	10
● Turning on the air conditioner	10
● Ventilating operation	10
● Cooling operation	10
● Cooling operation with auto fan mode	10
● Heating operation	10
● Heating operation with auto fan mode	10
● Auto cooling/heating operation	11
● Dry operation	11
● Selecting the temperature	11
● I FEEL function	11
● Sleep function	11
● Timer operation	12
● Timer operating modes	12
● Room temperature display	12
● Air direction operation	13
● Turning off the air conditioner	13
● On-unit operation	13
● Current clock time set	13
● Lock function	13
PROTECTION MODES	14
CARE AND MAINTENANCE	15
OPERATING TIPS	17
PRECAUTIONS	18
BEFORE CALLING FOR SERVICE	19

IF YOUR AIR CONDITIONER IS FOR COOLING ONLY, PLEASE DISREGARD THE HEATING INSTRUCTIONS

*PLEASE READ THESE INSTRUCTIONS **BEFORE** OPERATING THE AIR CONDITIONER*

INTRODUCTION

This Split Air Conditioner is designed for versatile applications:



- Cooling air in the summer.



- Dehumidifying the air at high humidity conditions.



- Heating.



- Air Filtration.



- Ventilation.
-

OPERATING TEMPERATURE RANGE:	
<i>Indoor</i>	<i>Outdoor</i>
Cooling: 16°-30°C	10°-46°C
Heating: 16°-30°C	-5°-21°C

IMPORTANT NOTICE:

- *This air conditioner must be grounded to protect against electrical shock.*

- *Installation of the air conditioner must be performed by an experienced air conditioning installer, observing good refrigeration practice.*

- *Electrical connections and power cord replacement should only be made by authorized electricians and in accordance with electrical regulations and local codes.*

- *Failure to comply with the manufacturer's installation and operation instructions could affect the performance of the air conditioner and the validity of the warranty.*

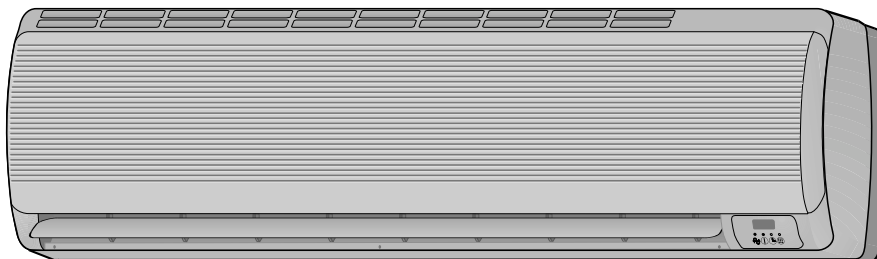

SYSTEM DESCRIPTION

MODELS: XLM36IRCB / GC34RCC

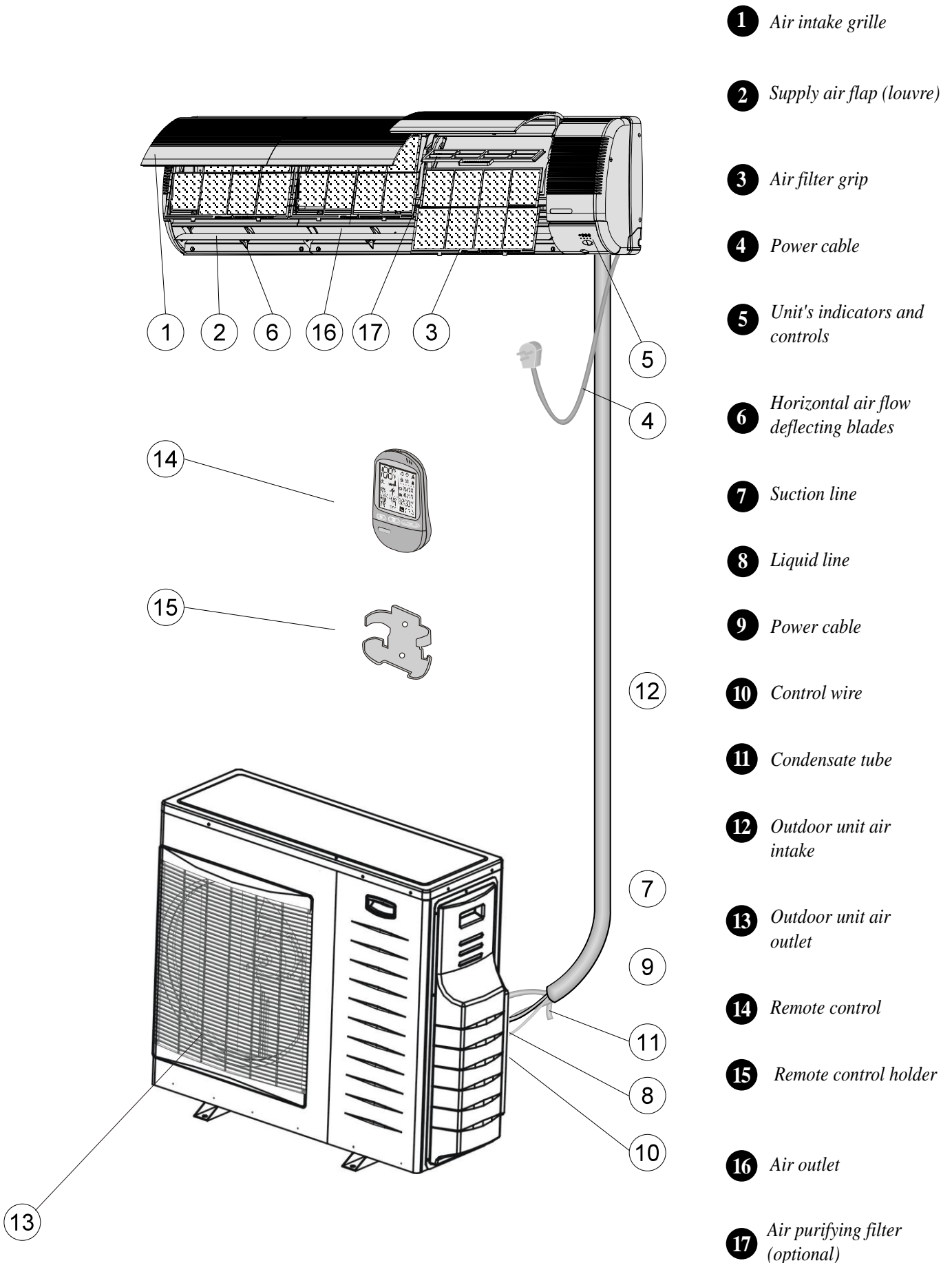

- 1 Air intake grille
- 2 Supply air flap (louvre)
- 3 Air filter grip
- 4 Power cable
- 5 Unit's indicators and controls
- 6 Horizontal air flow deflecting blades
- 7 Suction line
- 8 Liquid line
- 9 Power cable
- 10 Control wire
- 11 Condensate tube
- 12 Outdoor unit air intake
- 13 Outdoor unit air outlet
- 14 Remote control
- 15 Remote control holder
- 16 Air outlet
- 17 Air purifying filter (optional)

MODES OF OPERATION, FUNCTIONS AND FEATURES



COOL Cools, dehumidifies and filters the room air. Maintains desired room temperature.



HEAT Heats and filters the room air. Maintains desired room temperature.



AUTO Automatically switches from COOLING to HEATING or from HEATING to COOLING, maintaining the desired temperature according to the room conditions.



DRY Dehumidifies and softly cools the room. In DRY Mode, the air conditioner operates at an increased dehumidifying power. This function is recommended to be used when temperature is rather low but the humidity is high.



FAN Recirculates and filters the room air. Maintains constant air movement in the room.



AUTO FAN The air conditioner automatically selects the FAN speed in accordance with the room temperature. At the start, the unit operates at high fan speed. As the room air approaches to the desired temperature, the fan switches to a lower speed for quieter operation.

HOT KEEP

In HEATING and in AUTO FAN, the fan will be turned off when the compressor is not in operation and will not be restarted, unless the indoor coil reaches adequate temperature. This HOT KEEP feature prevents uncomfortable cold air drafts. Use of AUTO FAN is, therefore, recommended when the air conditioner is in HEATING mode.

I FEEL



Switches the temperature sensing point to the place where the remote control is located. (Generally the temperature sensor is located behind the intake grille of the air conditioner). This function is designed to provide a personalized environment by transmitting the temperature control command from the location next to you. The communication between the Remote Control and the unit is done by infra-red signal. Therefore, in using this function, the Remote Control should always be aimed, without obstructions, at the air conditioner.

TIMER



Real time control and display, automatically turns the air conditioner ON and OFF according to the time of day setting, ensuring comfort conditions before returning home, without wasting electricity. It turns the air conditioner off automatically when sleeping.

SLEEP



Designed to create comfortable sleeping conditions. When in COOLING mode, the temperature rises one degree centigrade after each consecutive hour, up to three hours, from the start of the mode. The temperature rise prevents the feeling of over-cooling while sleeping (when your body is at rest). In HEATING mode the reverse occurs; the air conditioner lowers its temperature one degree every hour. When in SLEEP mode, the air conditioner will be automatically turned off after seven hours. The result is a more comfortable and invigorating sleep, which leaves you feeling fresh and energetic in the morning.

%RH HUMIDITY MEASUREMENT (OPTIONAL) Measures and displays relative humidity between 30% and 90% at a temperature range of 15°C to 45°C.

AUTO FLAP The air flap (louvers) is automatically positioned for the most suitable blow-out angle, when COOL, HEAT, DRY or FAN modes are selected. When the air conditioner is turned off, the flap will close automatically for an aesthetic appearance.



Horizontal swing key Auto swing and fixed direction is circle and modulators;When press key once,fan direction board will be automatic,press again and fan direction board will be fixed.It retains when mode is switchover.



Vertical swing key (A1 & A2) Vertical swing is controlled by 2 step motors A1 & A2. There are 7 kinds of modes: 1) A1 & A2 at left together, 2) A1 & A2 at left-middle together, 3) A1 & A2 at middle together, 4) A1 & A2 at right-middle together, 5) A1 & A2 at right together, 6) A1 at left and A2 at right, 7) A1 & A2 auto swing.



ROOM TEMPERATURE Measures and displays room temperature.



BUZZER A soft buzzer will sound from the indoor unit display to indicate that a command sent by the remote control has been accepted and stored in the unit's memory. This feature may be easily cancelled by the user from the display panel.

ON UNIT OPERATION The air conditioner can be turned ON for COOLING or HEATING or be turned OFF directly from the indoor unit display panel without the use of the remote control.

3-MIN DELAYED RUN This compressor is protected by a three-minute delayed restart.

LOCK Freezes the last operation setting on the remote control. When LOCK is activated, the remote control will not be able to control the air-conditioner.

MEMORY The microprocessor retains the last data entry whether or not the unit is plugged in. Therefore, when the unit restarts after a power disruption or failure, it will resume operating in the same mode as before the power was disrupted.

ELECTROSTATIC FILTER (optional) They are capable of capturing small particles down to 0.1 microns, Such as atmospheric and house hold dust, coal dust, insecticide dust, mites, pollen, pet dander, tobacco smoke particles, cooking smoke and grease, mold fungi, bacteria, viruses and more.

IONIZER (optional) Ionizer make the air more fresh and more comfort. Slide switch (M) to the ON position and use the remote control to activate the ionizer. The blue light indicator (L) on the unit will light up indicating the ionizer in operation. To cancel the operation set slide switch to OFF position
Important Notice: When the air-conditioner is turned OFF or if the indoor fan stops operation the IONIZER stops automatically.

USE OF WIRELESS REMOTE CONTROL

PRIOR TO OPERATION

Prior to operating your air conditioner, make sure that:

- *The red tab protecting the remote control battery has been removed.*
- *For clock setting see page 11.*

WIRELESS REMOTE CONTROL PUTS ALL FUNCTIONS AT YOUR FINGERTIPS

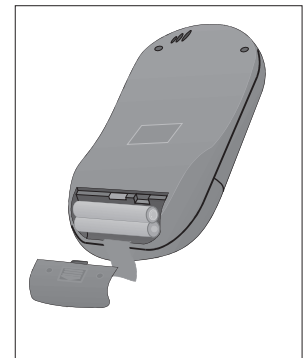

REMOTE CONTROL HOLDER

Use the remote control holder when unit is not in use.

Remote control can be slipped in or out its holder.



- Aim at the infrared signal receiver on the room air conditioner when operating.
- The remote control signal can be received at a distance of up to about 8 m.
- Ensure that there are no obstructions between the remote control and the signal receptor.
- Do not drop or throw the remote control.
- Do not place the remote control in a location exposed to direct sunlight, or next to a heating unit, and/or other heat source.
- Do not expose the air conditioner signal receiver to a strong light such as fluorescent lamp or sunlight

REMOTE CONTROL BATTERY CHANGE

- Remove the batteries from the remote control as shown.
- Use two 1.5 volt size AAA batteries
- For protecting the environment, please, return used batteries for recycling process.

ON-UNIT INDICATORS AND CONTROLS

MODELS: WS 090C / WS 090H / WS 100H

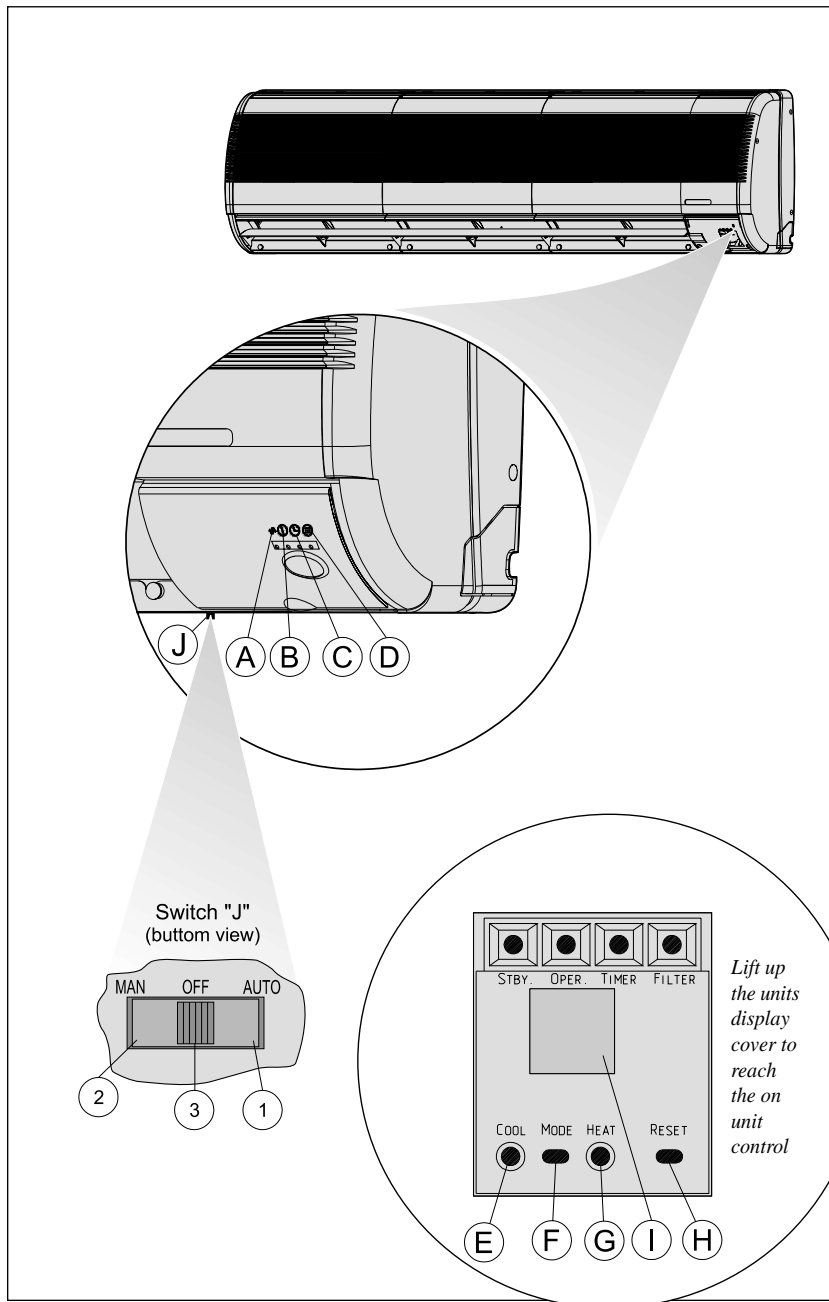

- A** **STAND-BY INDICATOR**
Lights up when the air conditioner is connected to power and ready to receive the remote control commands.
- B** **OPERATION INDICATOR**
Lights up during operation. Blinks once to announce that the remote control infrared signal has been received and stored. Blinks continuously in protection mode.
- C** **TIMER INDICATOR**
Lights up during timer and sleep operation.
- D** **FILTER INDICATOR**
Lights up when air filter requires cleaning.
- E** **COOLING INDICATOR**
Lights up only when Mode (F) is pressed.
- F** **COOL / HEAT / OFF / ON UNIT OPERATION BUTTON**
Used to switch the unit OFF or to turn it ON for COOLING or HEATING without the use of the remote control.
- G** **HEATING INDICATOR**
Lights up only when Mode (F) is pressed.
- H** **RESET BUTTON**
 - Press to turn off the FILTER indicator and to reset the filter function, after the clean filter has been reinstalled.
 - Press to cancel the buzzer announcer, if elected.
- I** **SIGNAL RECEIVER**
 - Receive signals from the remote control.
- J** **Horizontal air movement switch.**

ON-UNIT OPERATION

If the air-conditioner cannot be operated by the Remote Control unit, it can be turned on for cooling or heating, or completely turned off, by pressing MODE button (F) on the air-conditioner. The MODE button will change the operating status of the unit between - COOLING - HEATING - STAND-BY positions, every time it is pressed. Indicators (E), (G) or (A) will light up respectively, to indicate in which mode the air-conditioner operates.

On units for Cooling only, do not set MODE switch on HEAT position.

AUTO-HORIZONTAL AIR MOVEMENT (J)

For Auto movement turn switch (J) to position (1)

For desired air blades positioning turn switch momentarily to position (2) and then to (3).

Note: in some models this function is manual

REMOTE CONTROL

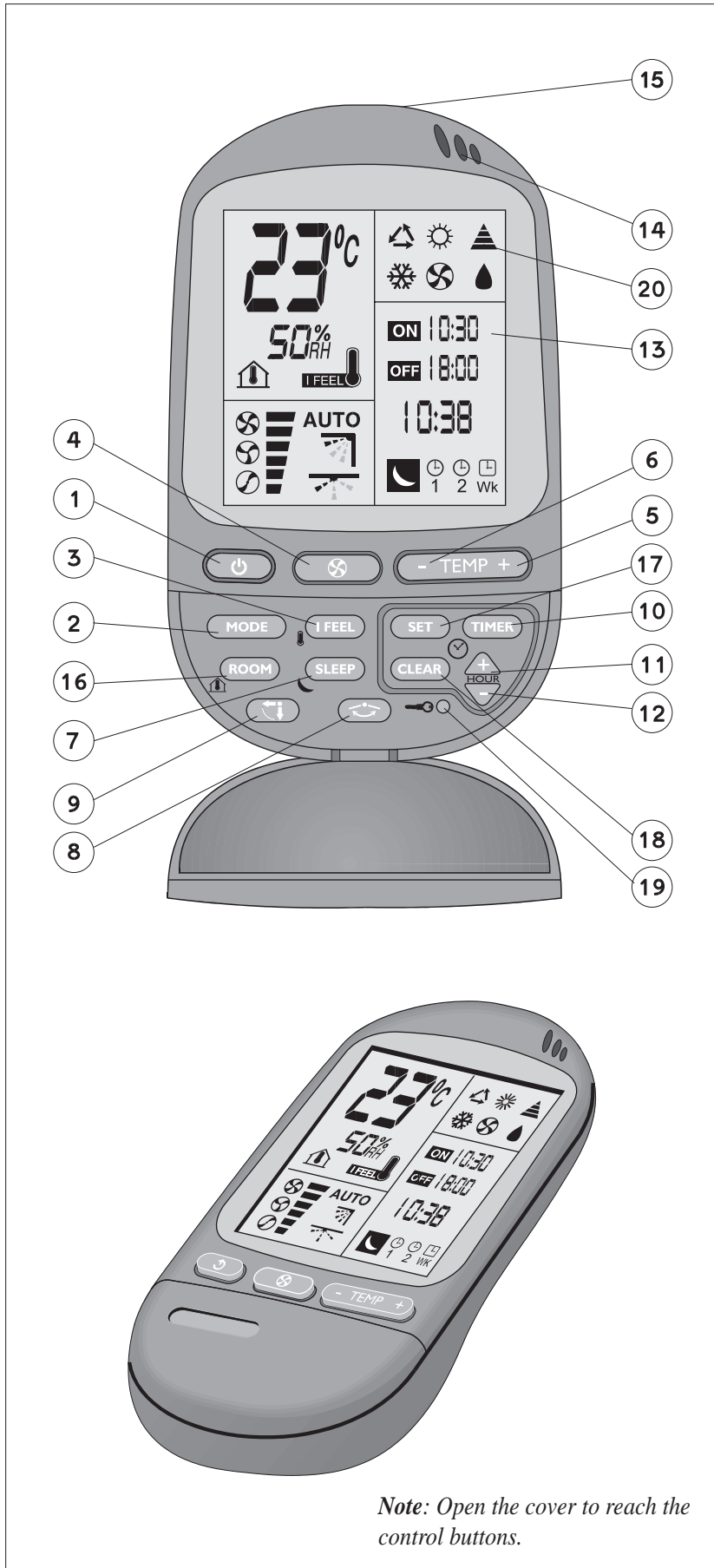

- 1** START/STOP button
- 2** Operation mode selection button
COOLING
HEATING
AUTO COOL / HEAT
DRY
FAN
- 3** I FEEL temperature sensing mode button
- 4** FAN SPEED and AUTO FAN button
- 5** Room temperature UP button
- 6** Room temperature DOWN Button
- 7** SLEEP button
- 8** Airflow direction MANUAL positioning control button
- 9** Airflow direction AUTO-CONTROL button
- 10** TIMER button
- 11** TIMER UP button
- 12** TIMER DOWN button
- 13** LCD operation display
- 14** I FEEL sensor
- 15** Infrared signal transmitter
- 16** ROOM temperature button
- 17** TIMER SET button
- 18** TIMER CLEAR button
- 19** LOCK button
- 20** Transmission sign

Note: Open the cover to reach the control buttons.

OPERATION PROCEDURE

TURNING ON THE AIR CONDITIONER

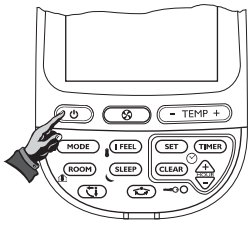

Press START/STOP button (1) to turn the air conditioner on. The operation indicator on the air conditioner will light up, indicating that the unit is in operation. Note that the LCD operation display (13) will always show the last mode of operation and previous function used. Follow the instructions if you choose to change the control settings; otherwise, the air conditioner will start and operate in the same mode and functions prior to being turned off.

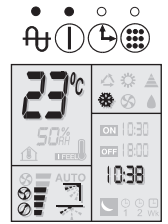

VENTILATING OPERATION

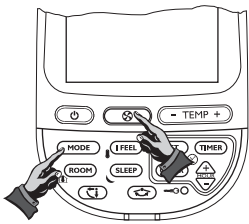

Select the ventilating mode by pressing MODE button (2). Switch to the desired fan speed by pressing FAN speed button (4).

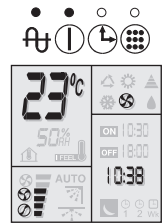

COOLING OPERATION

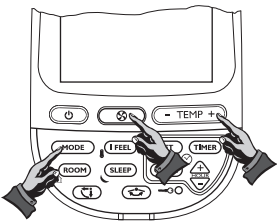

Select the COOLING mode by pressing MODE button (2). Switch to the desired FAN SPEED or to AUTO FAN by pressing button (4). Select suitable temperature setting. By selecting the COOLING mode, the air flap will move automatically to horizontal air delivery position, optimal for cooling.

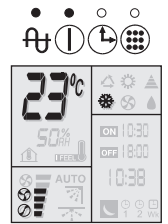

COOLING OPERATION WITH AUTO FAN MODE

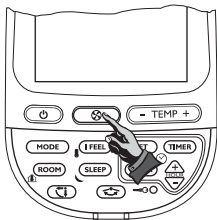

This operation starts with the highest air flow in order to quickly lower the room temperature. It will then automatically switch to the low air flow to quietly maintain the selected temperature.

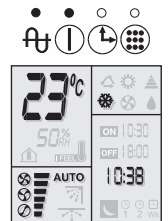

HEATING OPERATION

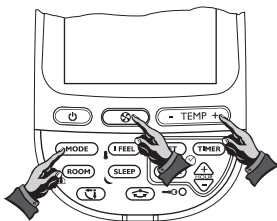

Select the HEATING mode by pressing MODE button (2). Switch to the desired FAN SPEED or to AUTO FAN by pressing FAN button (4). Select suitable temperature setting. By selecting the HEATING mode, the air flap will move automatically to vertical air delivery position, optimal for heating. The HOT KEEP function is provided. The fan will be turned off when the indoor coil temperature is not sufficiently hot to prevent uncomfortable cold air drafts. In some models the HOT KEEP function is operating in AUTO FAN mode only.

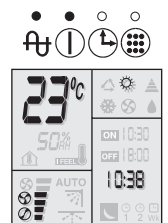

HEATING OPERATION WITH AUTO FAN MODE

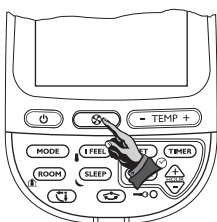

This operation starts with the highest air flow in order to quickly raise the room temperature. It will then automatically switch to a lower air flow to quietly maintain the selected temperature.

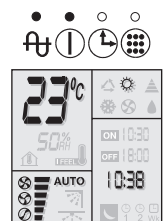

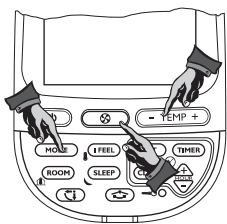

AUTO COOLING / HEATING OPERATION

Select the AUTO mode by pressing MODE button (2). Switch to the desired FAN SPEED or to AUTO FAN by pressing button (4). Select suitable temperature setting. The air flap will automatically move to either horizontal air delivery for cooling or to vertical air delivery for heating. At start, the air conditioner will select its mode of operation according to the room temperature and the temperature setting.

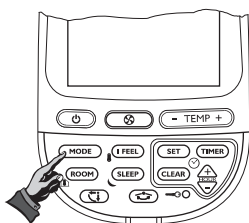
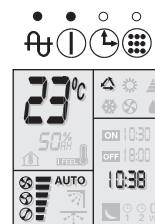

DRY OPERATION

Select the DRY mode by pressing MODE button (2). Select the suitable temperature setting. While in DRY mode, the air conditioner will operate at low fan speed, regardless of the fan setting on the LCD operation display. Fan might terminate operation from time to time to prevent from over cooling. By selecting the mode, the air flap will move automatically to optimal horizontal air delivery position.

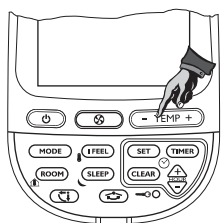
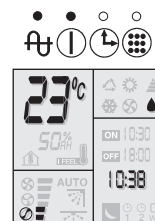

SELECTING THE TEMPERATURE

Press TEMP buttons (5) or (6) to change the temperature setting in the LCD operation display (13). The temperature setting is shown in degrees centigrade. A higher number indicates a higher room temperature. A lower number indicates a lower room temperature.

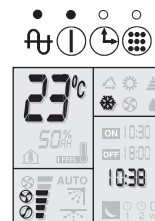

I FEEL FUNCTION

Press I FEEL button (3) to activate the I FEEL function. Thermometer sign will appear on the LCD operation display (13). Select suitable temperature setting.

Make sure that the remote control unit is aimed at the air conditioner, with the I FEEL sensor (14) in front. Prevent the I FEEL sensor from being affected by heat sources such as lamps, heaters, direct sun, etc. or from being directly affected by the air conditioner air flow. These may cause the sensor to transmit the wrong temperature data, thereby disturbing the performance of the I FEEL function.

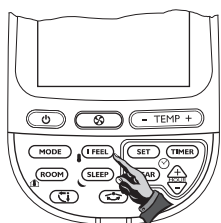

SLEEP FUNCTION

Press SLEEP button (7) to select the SLEEP function.

The sleep icon light while the sleep OFF time icon and the time which is 7 hours after current time blink as default. The default setting can be changed from 3 hr. to 12 hr. by pressing up and down buttons HOUR+ (11) and HOUR- (12) respectively. (The sleep timer will display the default time or the setting time plus the current time initially in the display).

For example : current time is 23:00 and the sleep mode is set, the sleep mode OFF time will be 6:00. If the sleep off time is set to 10 hr, then the sleep mode OFF time will be 9:00. All other timers will temporarily be suspended during the activation of the sleep timer.

The other timers will resume operation at the end of the SLEEP time.

To cancel the SLEEP function press one of the following:

- START / STOP button (1)
- SLEEP button (7)

NOTE: In some models the SLEEP icon lights only and the OFF time is set for seven hours as default.

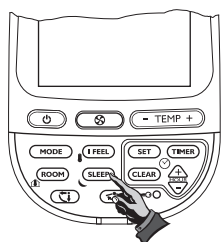

TIMER OPERATION

There are four timers that can be selected on the remote control. Two daily timers (designated as T1, T2), and two optional weekend timers (designated as WKT1, WKT2). Each timer can be selected by pressing TIMER button (10). To set each timer use time adjust up and down buttons Hour+ (11) and Hour- (12) respectively. SET button (17) to enable the timer and/or CLEAR button (18) to disable the timer.

Indicator (c) on the air conditioner will light up during timer operation.

NOTE: After a power failure the timer operation is cancelled, timer indicator on the air conditioner will blink, the unit will be automatically turned to stand-by mode and STAND-BY indicator lights. To resume the timer operation, follow the instructions below.

A. DAILY TIMER

The daily timers T1 and T2 can be set for ON and OFF separately for two different time periods. Once the timer is set it will resume operation when initiated.

B. WEEKEND TIMER (OPTIONAL)

The weekend timers WKT1 and WKT2 can be set for ON and OFF separately for two different time periods for two days only.

It will be effective on the day of setting and on the day after only.

At 24:00 on the second day, the WK timer will not be effective anymore and the daily timer will resume its effectiveness.

WKT1 - effective on the setting day





WKT2 - effective one day after the setting day.

NOTE:

1. During the weekend timer operation, the daily timers will be disabled.
2. The WK timers must be reactivated before every weekend.

C. SELECTING A TIMER

Press the TIMER button (10) to select a timer. Each time the TIMER button (10) is pressed, one of the four following timer icons will appear on the LCD display.





<p><i>Press TIMER button to select daily timer T1.</i></p>	<p><i>Press TIMER button to select daily timer T2.</i></p>	<p><i>Press TIMER button to select weekend timer WKT1</i></p>	<p><i>Press TIMER button to select weekend timer WKT2</i></p>
<p>1</p> 	<p>2</p> 	<p>3</p> 	<p>4</p> 
<p><i>Icon 1 of Timer T1 will blink</i></p>	<p><i>Icon 2 of Timer T2 will blink</i></p>	<p><i>Icons 1 and WK will blink</i></p>	<p><i>Icons 1 and WK will blink.</i></p>

TIMER OPERATING MODES

SETTING THE **ON** TIMER

Undertake the following steps after selecting a timer - T1,T2 or WKT1, WKT2, to set a timer for the start time of operation.

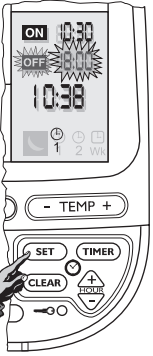



EXAMPLE:
Turning the air conditioner **ON** at 10:30.

<p><i>Press the SET button.</i></p>	<p><i>Set the hours and minutes.</i></p>	<p><i>Press the SET button</i></p>	<p><i>Press the CLEAR button.</i></p>
			
<p>1</p> <p><i>The ON icon & ON time digits will blink</i></p>	<p>2</p> <p><i>1. Set the ON time at 10:30 .</i> <i>2. Press the (HOUR+) up button to advance the time, and press the (HOUR-) down button to retract.</i></p>	<p>3</p> <p><i>1. The ON time is activated at 10:30 (the time ON icon will light)</i> <i>2. Time OFF icon & OFF time digits will blink.</i></p>	<p>4</p> <p><i>Timer OFF is cleared.</i></p>

SETTING THE **OFF** TIMER

Undertake the following steps after selecting a timer - T1,T2 or WKT1, WKT2, to set a timer for the stop time of operation.

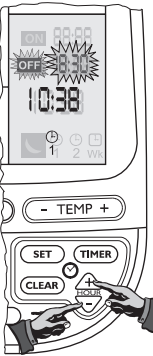
EXAMPLE:
Turning the air conditioner **OFF** at 18:30.

<p><i>Press the SET button.</i></p>	<p><i>Press the CLEAR button.</i></p>	<p><i>Set the hours and minutes.</i></p>	<p><i>Press the SET button</i></p>
			
<p>1</p> <p><i>The ON icon & ON time digits will blink.</i></p>	<p>2</p> <p><i>1. The ON time is cleared.</i> <i>2. OFF time icon & OFF time digits will blink.</i></p>	<p>3</p> <p><i>1. Set the OFF time at 18:30 .</i> <i>2. Press the (HOUR+) up button to advance the time, and press the (HOUR-) down button to retract</i></p>	<p>4</p> <p><i>OFF time is activated at 18:30 (the (timer OFF icon will light)</i></p>

NOTES:

1. The default setting for the timers are 7:00 and 18:00 for ON and OFF, respectively.
2. The timer mode will display always the last ON and OFF settings on the LCD display

SETTING THE ON AND OFF TIMERS

Undertake the following steps after selecting a timer - T1,T2 or WKT1, WKT2, to set a timer for the start and stop time of operation.

EXAMPLE:
Turning the air conditioner ON at 10:30 and OFF at 18:30.

Press the SET button



The ON icon & ON time digits will blink.

Set the hours and minutes.

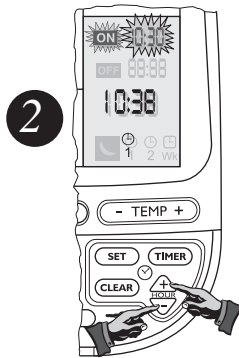

1. Set the ON time at 10:30.
2. Press the (HOUR+) up button to advance the time, and press the (HOUR-) down button retract.

Press the SET button

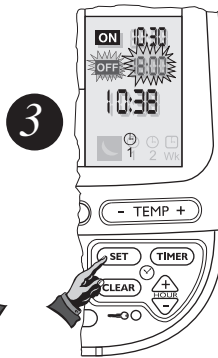

1. The ON time is activated at 10:30 (the time ON icon will light)
2. Timer OFF icon & OFF time digits will blink.

Set the hours and minutes.

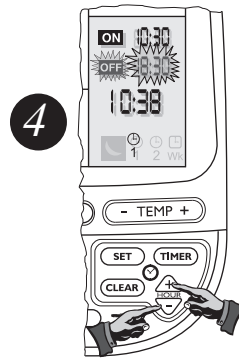

1. Set the OFF time at 18:30.
2. Press the (HOUR+) up button to advance the time, and press the (HOUR-) down button retract.

Press the SET button.

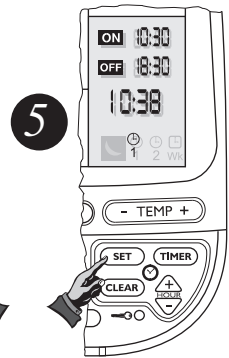

OFF time is activated at 18:30 (the timer OFF icon will light)

TO CHANGE THE TIME SETTING

EXAMPLE:
To change the ON time setting from 10:30 to 9:20 (while preserving the OFF time setting)

Press the TIMER button until the selected timer icon blinks.

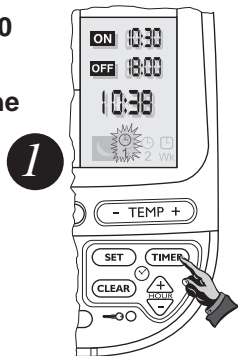

Note that the corresponding formerly set timer digits will display without blinking.

Press the SET button to enter edit mode

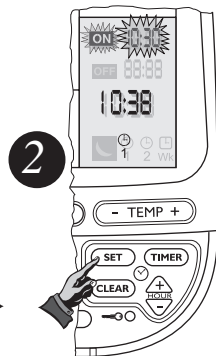

ON icon & ON time digits blink

Change the setting time to 9:20 by pressing on HOUR-.



ON icon & ON time digits blink

Press the SET button to save the new setting.

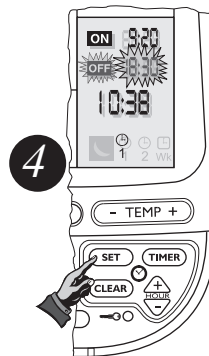

ON icon & ON time digits light while OFF icon & OFF time digits blink.

Press the SET button to confirm the previous timer OFF setting

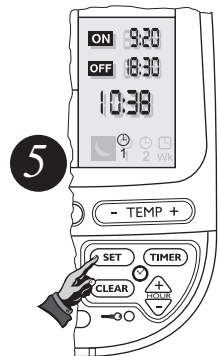

ON & OFF icons and time digits of the consequent timer light

TO CANCEL THE TIMER SETTING FOR A PARTICULAR TIMER

To cancel the ON time while keeping the OFF time setting.

Press **TIMER** button to select a timer.

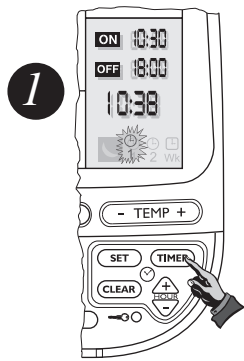

The selected timer icon blinks & the corresponding previous timer ON, OFF settings light.

Press **SET** button.

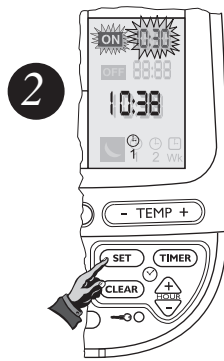

ON icon & ON time digits blink.

Press **CLEAR** button



ON time is cleared, OFF icon & OFF time digits blink.

Press **SET** button

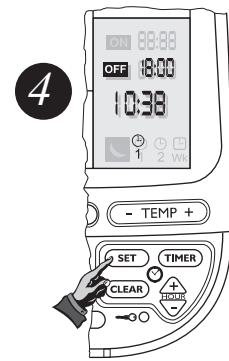

Confirm the new setting.

TO CANCEL THE **ON** & **OFF** TIME SETTINGS

Press **TIMER** button to select a timer.

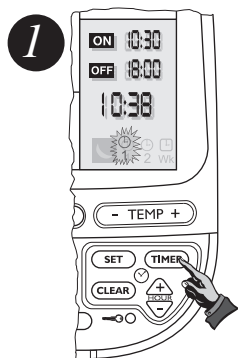

The selected timer icon blinks & the corresponding previous time ON, OFF settings light.

Press **CLEAR** button



All settings of the selected timer are cleared.

NOTES:

1. The default settings for the timers are 7:00 and 18:00, for ON and OFF respectively.
2. The timer mode will always display the last ON and OFF settings on the LCD display.
3. Pressing CLEAR button (18) for 5 seconds will cancel all timer settings and clear timer display.

AIR DIRECTION OPERATION

1. Automatic Vertical Air Swing

Press button (9) to activate the auto air swing. Press button (9) again to deactivate this function

2. Air Direction Positioning (See Option 1 on page 2)

Press button (8) to position the air flap to any desired angle.

3. Horizontal air flow control (See Option 2 on page 2)

A. AUTOMATIC HORIZONTAL AIR SWING

Press button (8) to activate the auto swing
The horizontal swing icon will light on the LCD display

B. MANUAL AIR DIRECTION POSITIONING

Press button (8) once again to position the air blades at any desired

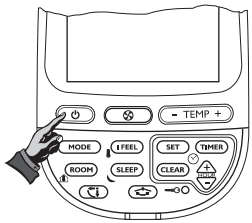
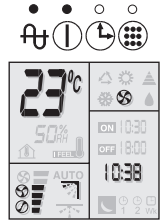
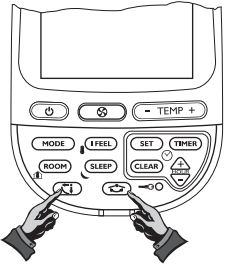

TURNING OFF THE AIR CONDITIONER

Press START/STOP button (1) to turn off the air conditioner. Indicator (B) on the air conditioner will be turned off. Indicator (A) will stay lit, indicating that the air conditioner is in STAND-BY mode and ready to accept any new command from the remote control. The remote control LCD will display the clock time. The last operating set-up will be kept for the next operation.

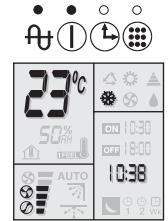

ROOM TEMPERATURE DISPLAY

By pressing on ROOM temperature, button (16), the measured room temperature and the room temperature sign will be displayed.

To cancel the ROOM Temperature display press on one of the following:

- Press again on ROOM temperature button (16).
- Change of MODE button (2)

NOTE: Room temperature range is between 0°C and 36°C in 1°C increments. Display should show "HI" or "LOW" to represent temperature that is above 36°C or below 2°C.

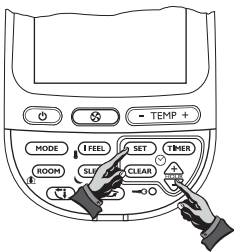
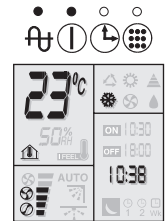

CURRENT CLOCK TIME SET

Clock setting is performed when batteries are inserted. The remote control displays the setting and the clock display will blink "0:00" or "12:00" AM (AM sign will blink, too) till a new time is set.

For clock setting, use buttons (11) and (12) for setting the hours and minutes, respectively, and then press timer SET button (17). The clock setting can be also performed by pressing timer SET button (17) for 5 seconds.

The clock display will blink, for new setting follow the steps described above.

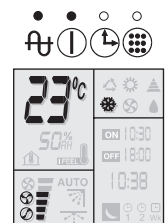

LOCK FUNCTION

By pressing LOCK button (19), the remote control will lock the last operation program. All the function buttons will be inoperative, including START/STOP button. By pressing LOCK button (19) again the remote control will be released from its locked position. When lock mode is functioning, the transmission sign (20) will be on.

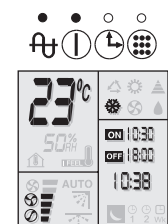

PROTECTION MODES

Your air conditioner includes several automatic protection modes, which enables you to use it virtually at any time and in any season, regardless of the outdoor temperature. Some of the protection modes are listed below:

Mode	Operation conditions	Protection from	Controlled remedy
Cooling and Dry	Low outdoor temperature	Indoor coil freezes up	Stops outdoor fan and compressor when approaching freezing conditions Resumes operation automatically.
	High outdoor temperature	Outdoor coil overheating	Stops compressor when approaching over heating conditions. Resumes operation automatically. Operating indicator (B) blinks.
Heating	Low outdoor temperature	Outdoor coil ice build up	Reverses operation from heating to cooling for short periods to de-ice outdoor coil. Operating indicator (B) blinks.
	High indoor or outdoor temperature	Indoor coil overheating	Stops outdoor fan and compressor when approaching high indoor coil temperature. Resumes operation automatically.

CARE AND MAINTENANCE

Before performing any maintenance procedure, be sure to disconnect the air conditioner from the power source.

CLEANING THE AIR FILTER

- Your air conditioner is provided with a filter cleaning indicator. When the indicator (D) lights up, the filters should be removed for cleaning.
- To remove the air filters, lift up the panel until it is locked in position (1). Push the air filters (3) up slightly to unlock them. Pull out the filters, clean the filter by washing in warm soapy water and dry thoroughly. Align and fit the filters in place. Close the panel by pushing it in the center to lock it in place.
- Reset button (H) to turn off indicator (D).

DO NOT OPERATE THE UNIT WITHOUT AIR FILTERS!

PURIFICATION FILTER REPLACEMENT

The air purification filter should be removed from the unit and replaced once a year:

- Remove air filter (3)
- Pull out the purification filter (4)
- Replace and secure the filter in its place
- Slide the filter back in its place.

Note: Proceed with the above instructions for the other filters.

CLEANING THE AIR CONDITIONER

- The front panel can be removed and cleaned separately.
- Raise up the panel to its maximum position (2) and pull it out of the unit.
- Wipe the unit with a soft dry cloth.
- Do not use hot water or volatile materials which could damage the surface of the air conditioner.

AT THE BEGINNING OF THE SEASON

- Make sure there are no obstacles blocking the flow of inlet or outlet air, in both indoor and outdoor units.
- Make sure the power is properly connected.

PROTECT THE ELECTRONIC SYSTEM

- Indoor unit and remote control must be at least 1 meter away from a TV, radio or any other home electronic appliance.
- Protect the inner unit from direct sun or lighting.

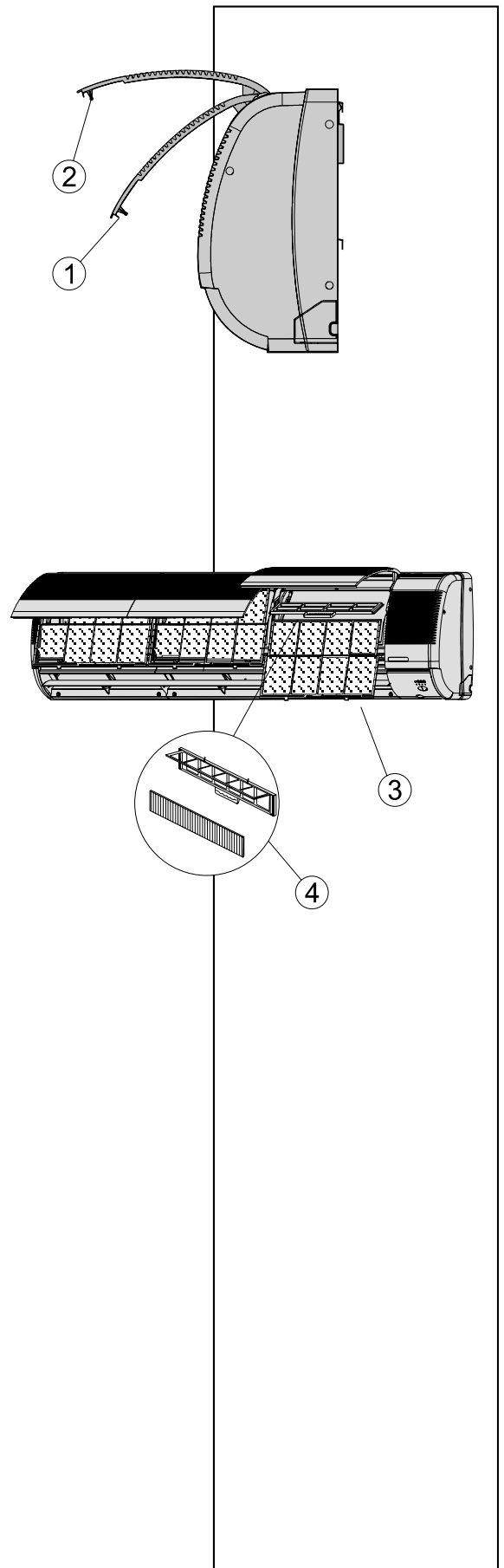

OPERATING TIPS

- Set a suitable room temperature; excessively low room temperature is not good for your health and wastes electricity. Avoid frequent setting of the temperature.
- During cooling, avoid direct sun. Keep curtains and blinds closed. Close doors and windows to keep the cool air in the room.
- Avoid generating heat or using of heating appliances while the air conditioner in cooling mode.
- Make sure that the air flap is positioned properly: horizontal flow in cooling and downward vertical flow for heating.
- Keep the room temperature uniform by adjusting the left/right vertical air blades.
- Position the air flap and the left/right air blades in such a manner as to prevent your body from being exposed directly to air drafts.
- During prolonged operation, ventilate the room occasionally by opening a window from time to time.
- In a power failure, the microprocessor memory is retained. When restarted, operation will be resumed in the last mode of operation. However, if the timer was used, the unit will be turned off by the timer only if the remote control is aimed at the unit. Otherwise the power failure will cause the timer data to be erased from the microprocessor memory.
- After turning on, allow more than 3 minutes for cooling, heating or dry operation to start.
- When DRY mode is used, make sure that the room temperature is between 20° and 27°C. When used out of this range, the unit may protect itself and become inoperative.
- When COOL or DRY modes are used, make sure that the room's relative humidity is below 78%. If the unit is used for a prolonged periods of time in high humidity, moisture may form on the air outlet and drip down.
- Remote control signals may not be received if the indoor unit controls cover is exposed to direct sunlight or strong light. In such a case, block the sunlight or dim the lighting.
- The remote control is operative in a range of 8 meters. If you are out of range, the remote control may have difficulties in transmitting signals.

PRECAUTIONS

- Use the proper electrical fuse.

Do not pull out the power cord unless the unit is turned off.



- Do not start or stop operation by disconnecting the power cord.

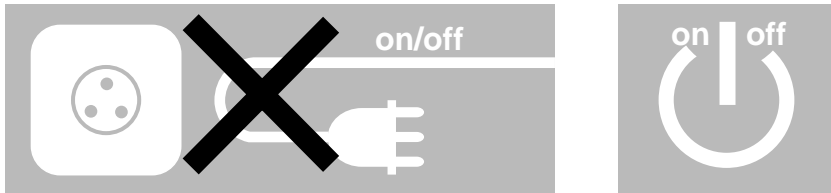

- Do not obstruct or block the air inlet or air outlet of the air conditioner.

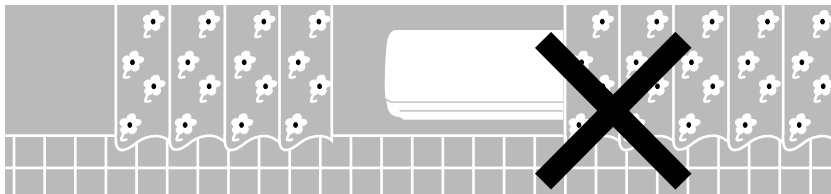

- Do not insert any objects in the air outlet of the indoor or outdoor units.

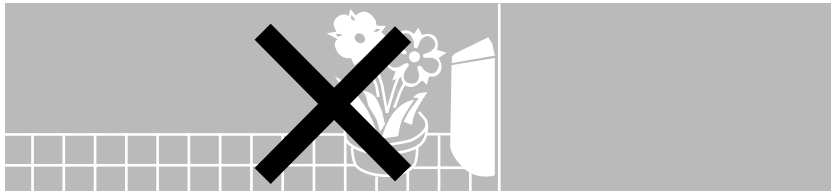

- Do not splash water on the air conditioner.

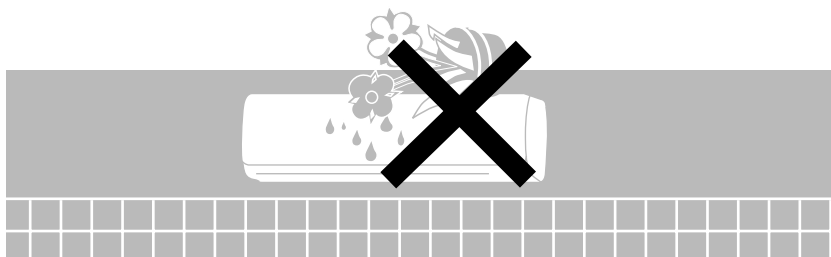

IF NOISE IS HEARD

There may be hissing sound during operation or just after shut down. This is caused by the refrigerant that is circulating inside the unit

There may be a cracking sound at starting and stopping the unit's operation. This is caused by heat expansion or contraction of plastics.

BEFORE CALLING FOR SERVICE

Before calling for service, please check the following common malfunctions and correct as needed.









Problem	Cause	Remedy
● Unit does not operate. Stand-by indicator does not light up	<ul style="list-style-type: none"> <input type="checkbox"/> Unit not connected to power <input type="checkbox"/> Power failure 	<ul style="list-style-type: none"> ■ Plug in the power cord ■ Check main fuse
● Unit does not operate. Stand-by indicator lights.	<ul style="list-style-type: none"> <input type="checkbox"/> Remote control malfunctions <input type="checkbox"/> The remote control is locked 	<ul style="list-style-type: none"> ■ Check remote control batteries ■ Try to operate from a closer distance ■ Start from on-unit controls ■ Perform reset operation by pressing buttons:(11)(12)(17)(18) for 5 sec. ■ Unlock the remote control
● Unit does not respond properly to remote control command	<ul style="list-style-type: none"> <input type="checkbox"/> IR signal does not reach unit <input type="checkbox"/> Distance between remote control and unit too large or aimed at from improper angle <input type="checkbox"/> IR receiver on-unit exposed to strong light source 	<ul style="list-style-type: none"> ■ Check for obstruction between unit and remote control. Clear if needed. ■ Get closer to unit ■ Dim lights, fluorescents especially
● Air does not blow out from indoor unit	<ul style="list-style-type: none"> <input type="checkbox"/> De-icing protection mode is activated <input type="checkbox"/> Unit in AUTO FAN mode <input type="checkbox"/> Over cooling in DRY 	<ul style="list-style-type: none"> ■ Normal operation in HEATING mode ■ Normal operation in DRY mode
● COOLING, DRY or HEATING does not start immediately	<ul style="list-style-type: none"> <input type="checkbox"/> 3-min. compressor delayed start 	<ul style="list-style-type: none"> ■ Normal operation for these modes
● Unit functions but does not perform sufficiently	<ul style="list-style-type: none"> <input type="checkbox"/> Improper temperature setting <input type="checkbox"/> Unit capacity insufficient for load or room size 	<ul style="list-style-type: none"> ■ Reset temperature ■ Consult your dealer
● Filter indicator lights up	<ul style="list-style-type: none"> <input type="checkbox"/> Air filter needs cleaning. 	<ul style="list-style-type: none"> ■ Clean filter, reinstall and reset indicator

INSTALLATION INSTRUCTIONS

1. ACCESSORIES SUPPLIED WITH AIR CONDITIONER.
2. LOCATION OF INDOOR AND OUTDOOR UNITS.
3. ELECTRICAL REQUIREMENT.
4. INSTALLATION OF THE INDOOR UNIT.
5. CONDENSATE HOSE CONNECTION.
5. ELECTRICAL CONNECTIONS BETWEEN INDOOR AND OUTDOOR UNITS.
7. REFRIGERANT TUBING.
8. FINAL TASKS.

1

ACCESSORIES SUPPLIED WITH THE AIR CONDITIONER

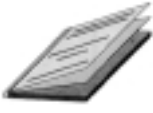
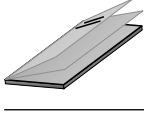
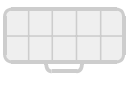
Shape	Name	Qty	Used for
	Mounting rail	1	Wall mounting of indoor unit
	Remote control with batteries	1	Operation of unit
	Remote control bracket	1	Wall mounting of remote control
	Screws Washers Dowels	4	Wall mounting of indoor unit
	Screws, Dowels	2	Wall mounting of the remote control bracket
	Outdoor unit drain connector	1	Outdoor unit water drain
	Mounting pads	4	Padding of outdoor unit bottom supports
	Cable ties	4	Securing wires in the indoor and outdoor unit
	Cable terminals	1	Securing of grounding wire on the indoor and outdoor unit
	Operation instructions	1	Users' reference
	Installation instructions and template	1	Installers' reference
	Air purifying filter (Optional)	2	Cleaning the air

2

LOCATION OF INDOOR AND OUTDOOR UNITS

Select the location considering the following:

INDOOR UNIT

1. Choose a location which will provide good air circulation. Ensure that no objects or furnishings prevent air circulation.
2. Do not install the unit near a heat source or where it will be exposed to direct sunlight.
3. The location must allow convenient electrical drainage and tubing connections.
4. Installation site should provide an easy passage to outdoors.
5. The unit must be mounted on a strong wall that will withstand vibration-generated noise.
6. Install the mounting plate as shown.

OUTDOOR UNIT

1. The location must allow easy servicing and provide good air circulation.
2. The unit may be suspended from a wall by a bracket (optional) or located in a free standing position on the floor (preferably slightly elevated).
3. Before the unit is suspended, ensure that the bracket is firmly connected and the wall is strong enough to withstand vibrations..
4. Unit location should not disturb neighbors with noise or exhaust air stream.
5. Place the mounting pads under the unit legs.
6. Install the outdoor unit as shown. Refer to the technical and service manual for allowed distances.
7. When the unit is installed on a wall, install the drain connector hose as shown.

Fig 1

1. Bottom of the outdoor unit
2. Drain connector

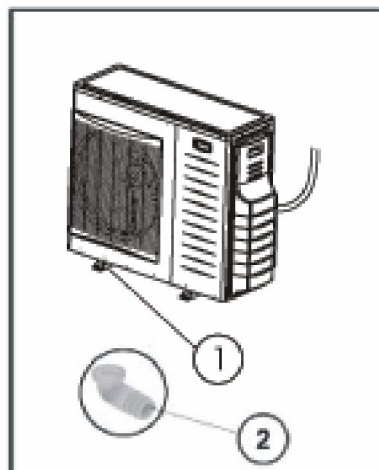

Fig 1

1. Drain installation Example

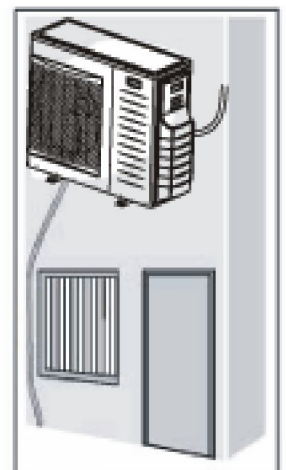

Fig.3

- 1. To attach
- 2. To remove

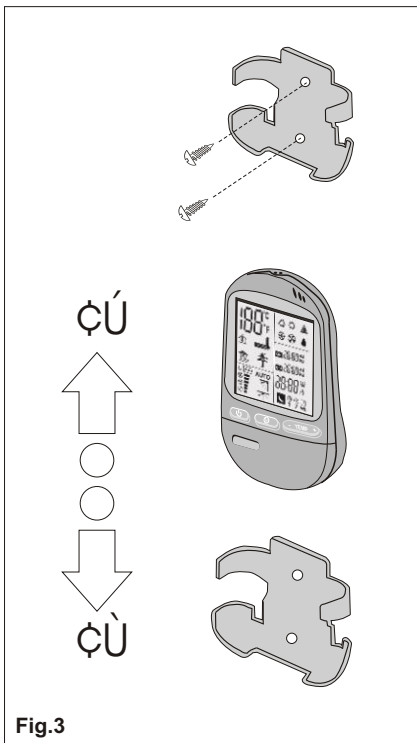

Fig.3

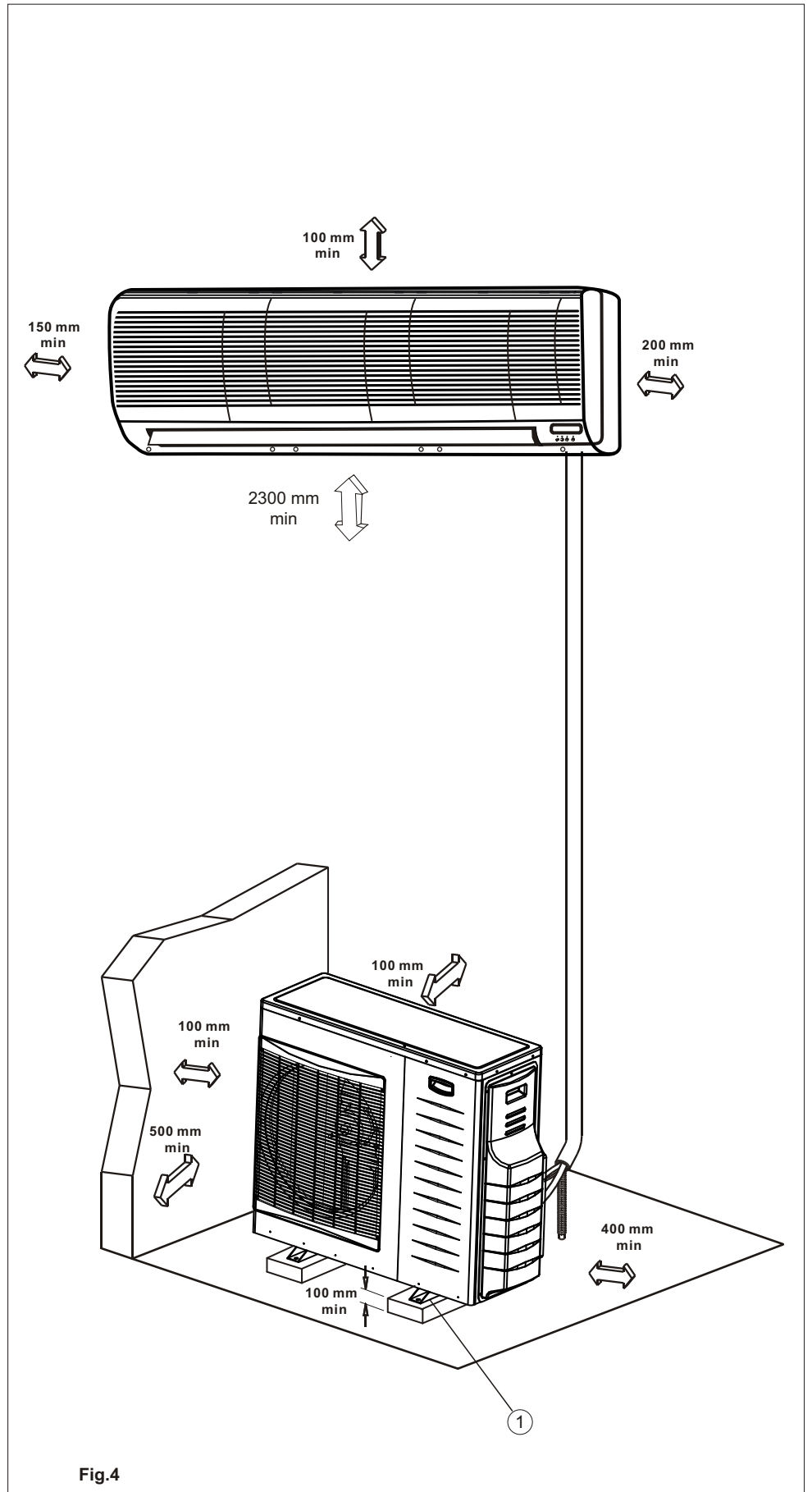

Fig.4

Fig.4
1. Mounting pads(x4)

3

ELECTRICAL REQUIREMENTS

Electrical wiring and connections should be made by qualified electricians and in accordance with local electrical codes and regulations. The air conditioner units must be grounded.

The air conditioner unit must be connected to an adequate power outlet from a separate branch circuit protected by a time delay circuit breaker, as specified on unit's nameplate.

Voltage should not vary beyond $\pm 10\%$ of the rated voltage.

4

INSTALLATION OF THE INDOOR UNIT

INSTALLATION OF THE FRONT INDOOR UNIT

Removal of the right cover

1. Remove screw caps (2) from cover (1).
2. Remove the three screws (3).
3. Rotate the right cover to remove it.

Removal of the bottom cover

1. Remove screw caps (5) from the air outlet.
2. Loosen the screws (6) of the air outlet.
3. Pull the cover (4) down and then to the right to disengage it.

Fig.5
 1. Right cover
 2. Screw caps
 3. Screw
 4. Bottom cover
 5. Screw caps
 6. Screws

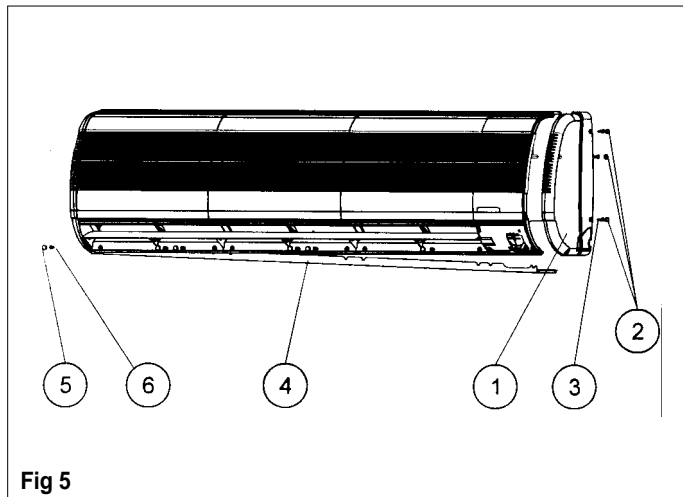

REFRIGERATION TUBE ROUTING

1. There are four possible routes for installing the refrigeration tube as shown.
2. For routes (2) or (4), cut the side notches in the left or right panel.

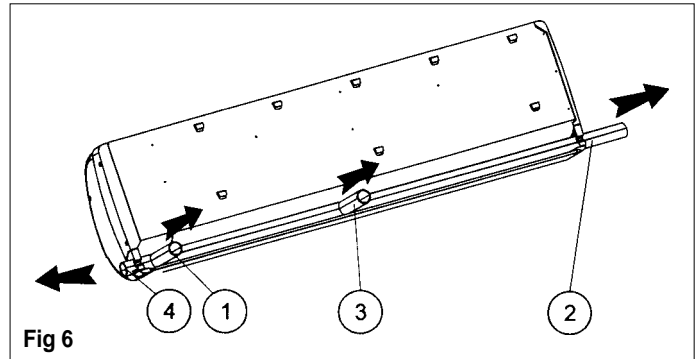
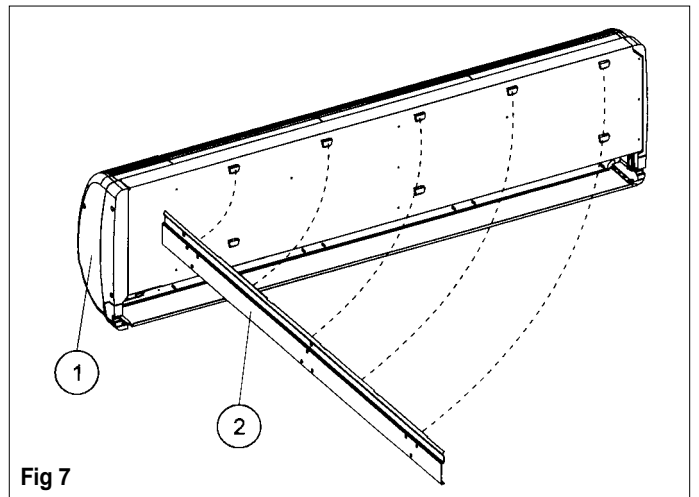

Fig.6
 1. Righthand rear outlet
 2. Lefthand outlet
 3. Lefthand rear outlet
 4. Righthand outlet

INSTALLATION OF THE MOUNTING RAIL

1. Figure 7 shows the location of the mounting rail relative to the unit size.
2. Locate the mounting plate as shown on the wall in a horizontal position, using a spirit level.
3. Mark the position of the four mounting holes on the wall and drill holes to accommodate the dowels.
4. Mount the mounting rail on to the wall by the screws. Ensure screws are tightened properly.
5. Mount the unit on the mounting rail.

Fig.7
 1. Indoor unit.
 2. Mounting rail.



PENETRATION OF WALL FOR TUBING

1. Mark the location of the hole on either side, according to tubing routings, as shown. and drill it at a 5° downward angle, as shown.
2. The hole is drilled at an angle to prevent condensed or rain water from penetrating back into the room.
3. Trim the hole in the wall with a $\varnothing 70$ mm commercial plastic tube.

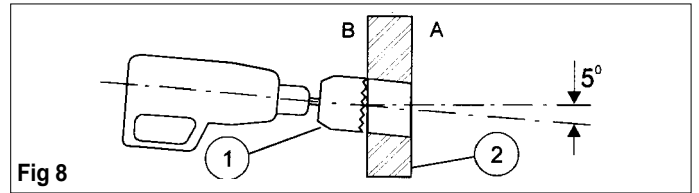

Fig 8

- A. Outdoor side
B. Indoor side
1. Drill $\varnothing 70$ mm
 2. Wall

5

CONDENSATE HOSE CONNECTION

1. Attach the condensate drain hose to the corrugated hose in the rear groove of the indoor unit.
2. Wrap the drain hose together with the refrigerant tubes and electrical cables.
3. Ensure that the condensate drain hose is installed at all points in a downward slope manner.

4. When installing the drain hose avoid traps and U-bends. The end of the drain hose should not be immersed in water.

5. For a lefthand outlet, lay the drain hose on the bottom of the indoor unit rear groove.

6. When the installation location requires long horizontal sections, a vent must be provided at the top of the hose to prevent overflow of the unit drain pan.

7. Upon completing the installation, test the water drain by pouring at least two liters of water into the unit drainpan. Check that the water drains off.

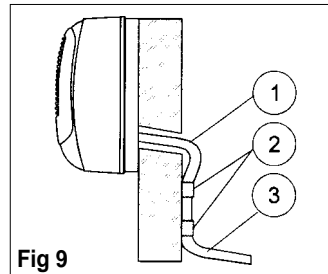

Fig 9

Fig. 9

1. Drain hose
2. Clamp
3. Downward slope

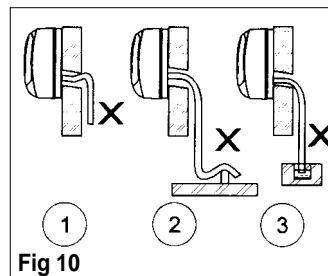

Fig 10

Fig. 10

1. Trap
2. U-bend
3. End immersed in water

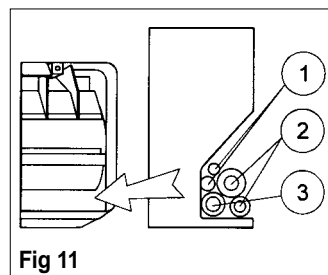

Fig 11

Fig. 11

1. Electric cable
2. Refrigerant tubing
3. Condensate drain hose

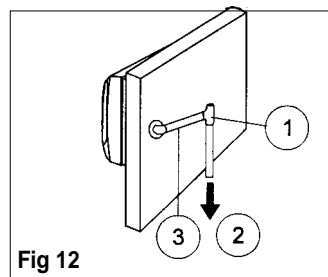

Fig 12

Fig. 12

1. Vent
2. Downward drain
3. Water drain hose

ELECTRICAL CONNECTIONS BETWEEN INDOOR AND OUTDOOR UNITS

- To connect the indoor unit with the outdoor unit use the following electrical cables, protected for outdoor use:

SINGLE PHASE MODELS (see Fig. 14a)

Cooling and heating model:

Multi wire cable :

5 wires x 2.5 mm²

Twin wire cable:

2 wires x 0.5 mm² - For low voltage.

Cooling only model:

Multi wire cable :

4 wires x 2.5 mm².

Twin wire cable:

2 wires x 0.5 mm² - For low voltage.

For units above 10 KW (see Fig.14b)

The main power supply (5) will be connected to the outdoor unit.

THREE PHASE MODELS (see Fig. 14c)

The main power supply electrical cable must be of H05VV-K5G type and contain 5 x2.5 mm² conductors, connected to a thermally protected circuit breaker 3 x 12.5A.

- Prepare inter-unit cable ends for connections.
- Connect the cable ends to the terminals of the indoor and outdoor unit, as shown in Fig. 14a, Fig. 14b and Fig. 14c. Be sure to match the colored wires with the numbers shown on the indoor and outdoor unit terminal boards.
- Connect the yellow/green ground wire to the ground terminal screw.
- Secure multiple wire power cable with the cable clamps.
- Fasten the twin wire cable to the power cable with cable ties.

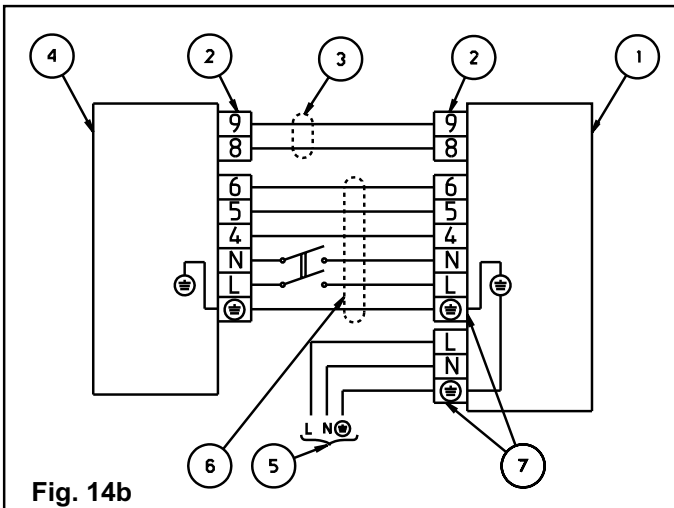
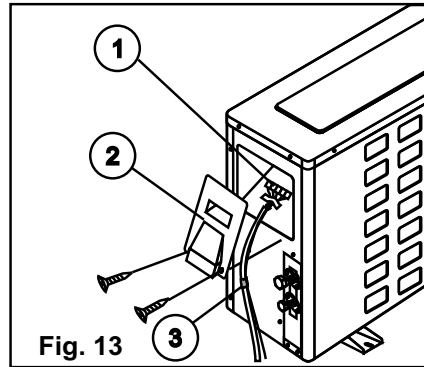

Fig. 14a/14b/14c

- Outdoor unit
- Terminal board
- Control cable
- Indoor unit
- Power supply
- Electrical interconnecting cable
- Terminal board male/female

Fig. 13

- Terminals
- Cover
- Cable tie



NOTES:

- The wire color codes can be selected by the installer.
- Wires leading to terminals 8 and 9 must be in a separate twin wire cable, otherwise the electronic controls will be subject to operational malfunctions.
- For cooling only model. Wire (5) should not be connected to terminal No. 5.
- In some models the twin wire cable is factory-connected to the indoor unit.

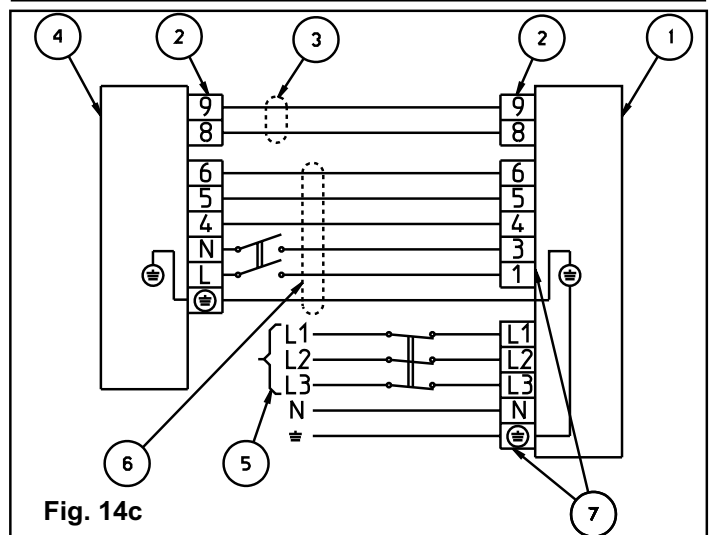
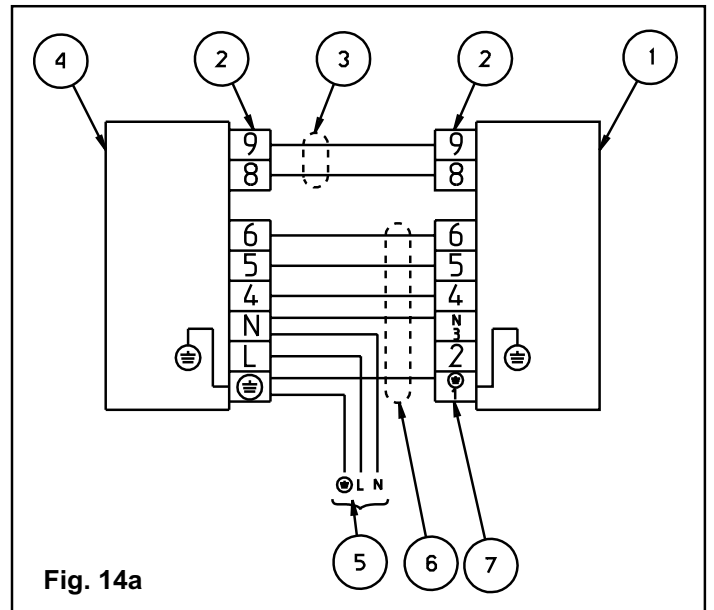

REFRIGERANT TUBING

CONNECT THE INDOOR TO THE OUTDOOR UNIT

The indoor unit contains a small quantity of Helium. Do not unscrew the nuts from the unit until you are ready to connect the tubing. The outdoor unit is supplied with sufficient refrigerant charge for a 6 m tubing length. For additional charge, please refer to outdoor unit nameplate.

To prevent crushing, bend tubes using a bending tool.

NOTE: Use refrigeration type copper tubing only.

1. Use tubing diameter that corresponds to the tubing diameter of the indoor and outdoor units. Note that the liquid and suction tubes have different diameters. (See tube size, torque tightening table.)
2. Place flare nuts on tube ends before preparing them with a flaring tool. Use the flare nuts that are mounted on the supplied outdoor and indoor units.
3. Connect the four ends of the tubing to the indoor and outdoor units.
4. Insulate each tube separately, and their unions, with at least 6 mm of insulation. Wrap the refrigerant tubing, drain hose and electric cables together with a vinyl tape (UV protected).

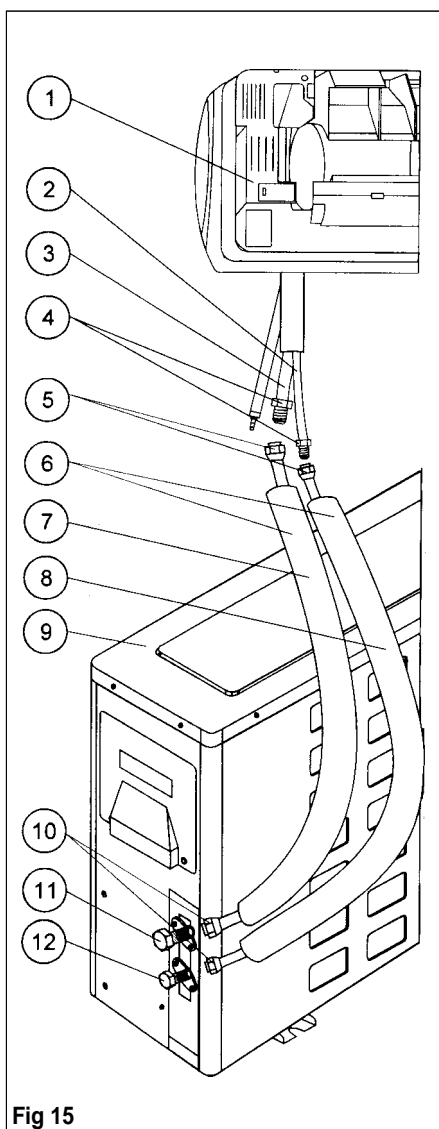

Fig 15

Caution!

When unscrewing the valve caps, do not stand in front of them or the spindles at any time, as the system is under pressure.

Fig. 15

1. INDOOR UNIT
2. Liquid tube (small dia.)
3. Suction tube (large dia.)
4. Plugs
5. Flare nuts
6. Tubing insulation
7. Suction tube
8. Liquid tube
9. OUTDOOR UNIT
10. Flare nuts
11. Suction valve (larger)
12. Liquid valve (small)

Tightening torques of unions and valve caps:

TUBE SIZE	TORQUE
Liquid line 3/8"	30-35 N.M.
Suction line 1/2"	50-54 N.M.
Suction line 5/8"	75-78 N.M.
Suction line 3/4"	80-100 N.M.

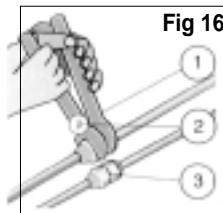

Fig 16

- Fig. 16
1. Wrench
 2. Torque wrench
 3. Union

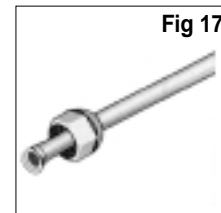

Fig 17

- Fig. 17
- To prevent refrigerant leakage, coat the flared surface with refrigeration oil

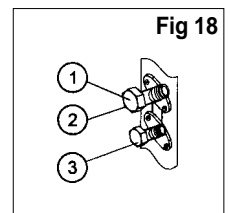

Fig 18

- Fig. 18
1. Suction valve
 2. Service port
 3. Liquid valve

EVACUATION OF THE REFRIGERATION TUBES AND THE INDOOR UNIT

After connecting the unions of the indoor and outdoor units, purge the air from the tubes and indoor unit as follows:

1. Connect the charging hoses with a push pin to the low and high sides of the charging set and the service port of the suction and liquid valves. Be sure to connect the end of the charging hose with the push pin to the service port.
2. Connect the center hose of the charging set to a vacuum pump.
3. Turn on the power switch of the vacuum pump and make sure that the needle in the gauge moves from 0 MPa (0 cm Hg) to -0.1 MPa (-76 cm Hg). Let the pump run for fifteen minutes.
4. Close the valves of both the low and high sides of the charging set and turn off the vacuum pump. Note that the needle in the gauge should not move after approximately five minutes.
5. Disconnect the charging hose from the vacuum pump and from the service ports of the suction and liquid valves.
6. Tighten the service port caps of both suction and liquid valves.
7. Remove the valve caps from both valves, and open them using a hexagonal Allen wrench.
8. Remount valve caps onto both of the valves.
9. Check for gas leaks from the four unions and from the valve caps. Test with electronic leak detector or with a sponge immersed in soapy water for bubbles.

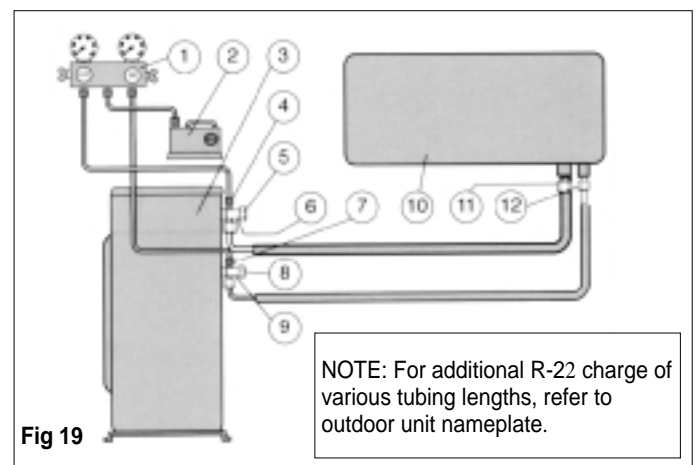

Fig 19

- Fig. 19
1. Charging set
 2. Vacuum pump
 3. OUTDOOR UNIT
 4. Service valve

5. Cap
6. Suction valve
7. Service valve*
8. Cap

9. Liquid valve
 10. INDOOR UNIT
 11. Suction flare connection
 12. Liquid flare connection
- * In some models only

NOTE: For additional R-22 charge of various tubing lengths, refer to outdoor unit nameplate.

8

RESTRICTOR INSTALLATION

THIS INDOOR UNIT IS SUPPLIED WITH AN EXTRA INSTALLATION FOR CONNECTION TO THE INDOOR LIQUID TUBE DURING INSTALLATION. WITHOUT THIS KIT THE UNIT WILL NOT OPERATE PROPERLY IN THE HEATING MODE. (See Fig. 22)

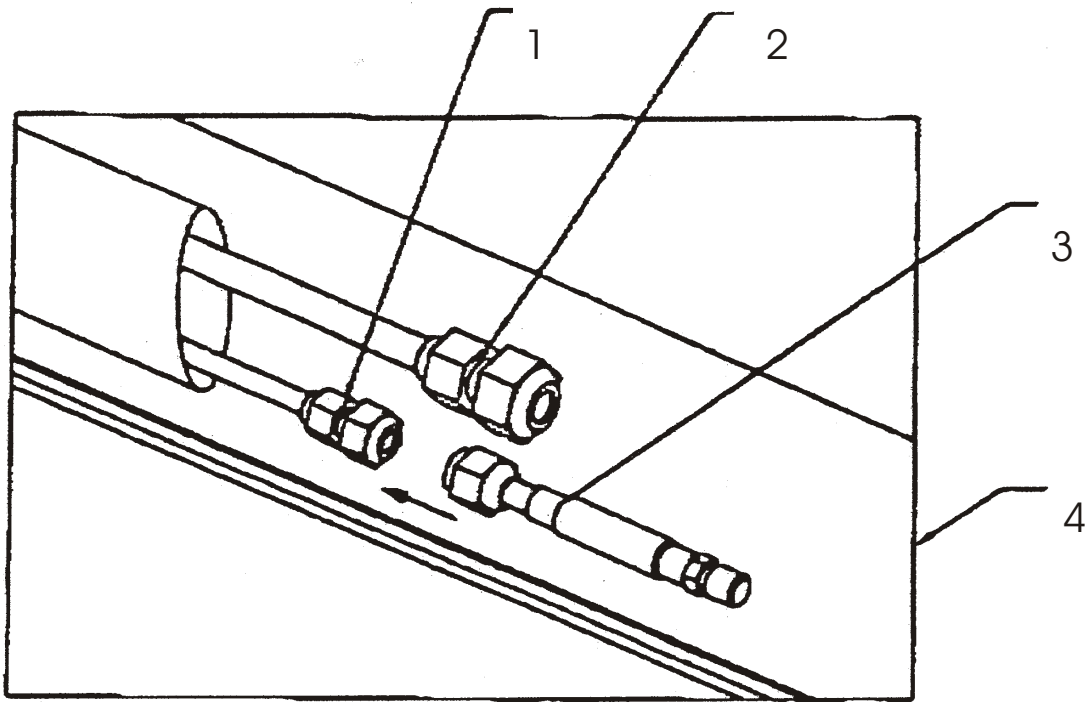

Fig.22

- 1. LIQUID TUBE
- 2. SUCTION TUBE
- 3. RESTRICTOR
- 4. INDOOR UNIT

9

FINAL TASKS

1. Replace all valve caps and ensure that they are tightened properly.
2. Fill gaps on the wall between hole sides and tubing with sealer.
3. Attach wiring and tubing to the wall with clamps where necessary.
4. Operate the air conditioner togetherwith the customer and explain all functions.
5. Explain filter removal, cleaning and installation.
6. Give the operating and installation manuals to the customer.



TECHNICAL ENQUIRIES

1800 1800 04

SERVICE / WARRANTY

1300 553 000

MELBOURNE

745 Springvale Road
Mulgrave VIC 3170

TEL: (03) 9271 3505

FAX: (03) 9271 3540

SYDNEY

CNR Marion St & Airport Ave
(P.O. Box. VQ)Banktown
Airport NSW 2200

TEL: (02) 9793 3644

FAX: (02) 9793 3688

BRISBANE

Unit 9, 123 Muriel Ave
Moorooka QLD 4105

TEL: (07) 3392 8113

FAX: (07) 3392 8115

ADELAIDE

Offices on the parkSuite 27, 8
Greenhill Road
Wayville SA 5034

TEL: (08) 8372 7866

FAX: (08) 8372 7816

PERTH

Suite 23, 350 Cambridge St
Wembley WA 6014

TEL: (08) 9284 0800

FAX: (08) 9284 0600

NEWCASTLE

Suite 3, 19 Darby Street
Newcastle NSW 2300

TEL: (02) 4940 4652

FAX: (02) 4940 4653

NEW ZEALAND

517A Rosebank Road
Avondale, Auckland NZ

TEL: (09) 820 0333

FAX: (09) 820 0332

NZ Tech Support Freecall

TEL: 0800 180 094

www.airwell.com.au