

# AIR CONDITIONER SPLIT WALL MOUNTED

---

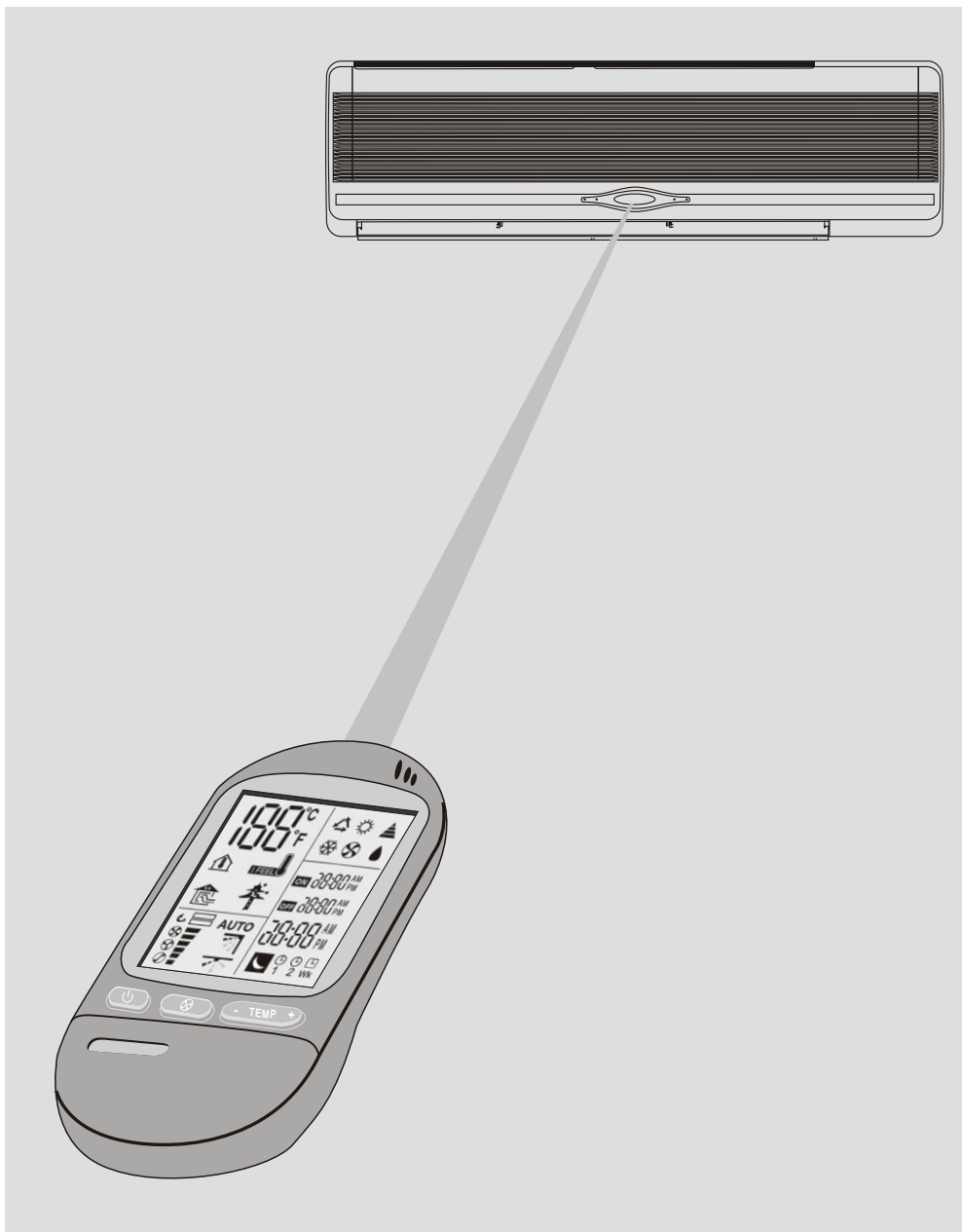

XLM30 & 32 RCB / GC30 & 32RCC

## PROGRAMMING AND OPERATION MANUAL INSTALLATION INSTRUCTIONS

# CONTENTS

Introduction	1
System Description	2
Modes of Operation, Functions and Features	3
Use of Wireless Remote Control	5
On-unit indicators and controls	6
Remote Control	7
Operation procedure	8
•Turning on the Air Conditioner	8
•Ventilating Operation	8
•Cooling Operation	8
•Cooling Operation with Auto Fan Mode	8
•Heating Operation	8
•Heating Operation With Auto Fan Mode	8
•Auto Cooling / Heating Operation	9
•Dry Operation	9
•Selecting The Temperature	9
•I FEEL/ROOM Temp Function	9
•Sleep Function	9
•Timer Operation	10
•Timer Operating Modes	11
•Air Flow velocity and DIRECTION Adjustment	14
•Turning off the Air Conditioner	14
•Current Clock Time Set	14
•Lock Function	14
•Ionizer/Fresh Air Operation	14
Protection Modes	15
Care and Maintenance	16
Operating Tips	17
Precautions	18
Before Calling For Service	19

---

**If your air conditioner is for cooling only, please disregard the heating instructions**

---

Please read these instructions **before** operating the air conditioner

---

# INTRODUCTION

---

The air conditioner is designed for various uses:



- Cooling in summer



- Dehumidifying at high humidity conditions



- Heating



- Ventilation
- 

**Operating Temperature Range**  
(According to  $T_1$  temperature condition)

Cooling:  $21^{\circ} \sim 43^{\circ}\text{C}$

Heating:  $-7^{\circ} \sim 21^{\circ}\text{C}$

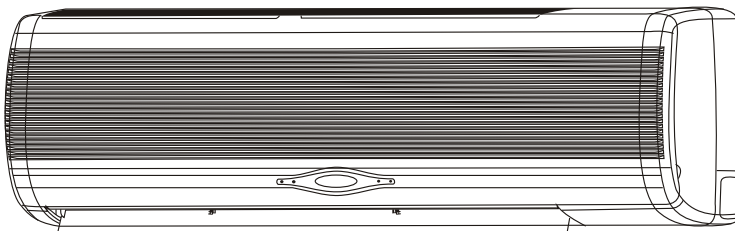

## **IMPORTANT NOTICE:**

- The air conditioner must be grounded to protect against electrical shock.
- Installation of the air conditioner must be performed by an experienced air conditioning installer, observing good refrigeration practice.
- Electrical connections and power cord replacement should only be made by authorized electricians and in accordance with electrical regulations and local codes.
- Failure to comply with the manufacturer's installation and operation instructions could affect the performance of the air conditioner and the validity of the warranty.

# SYSTEM DESCRIPTION

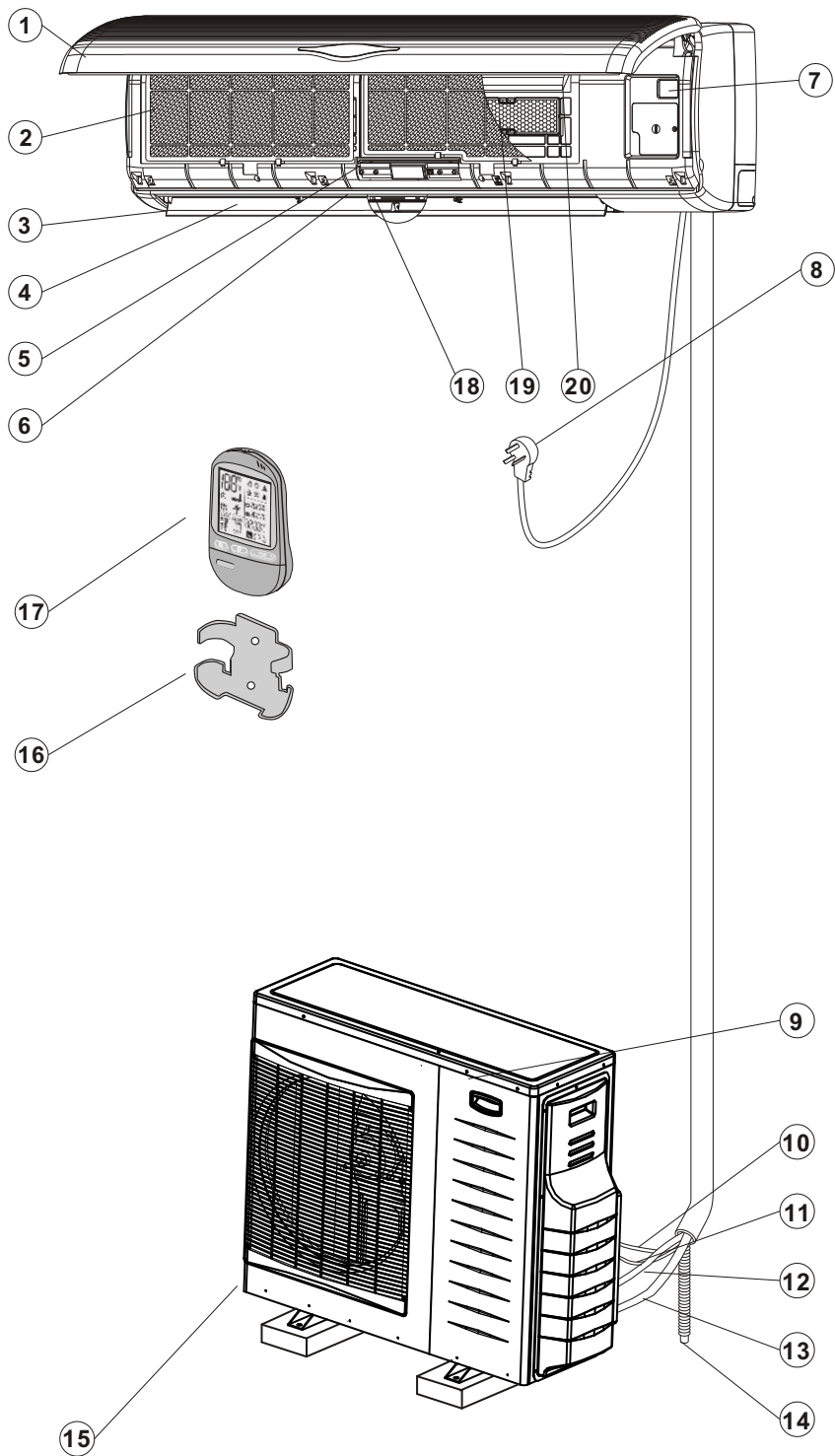

1. Air intake grill
2. Air filter
3. Supply air flap
4. Air outlet
5. unit's indicator
6. Horizontal Air flow Deflecting louvers
7. On unit's controls
8. Power cord
9. Outdoor unit air intake
10. Power cable
11. control wire
12. Liquid line
13. Suction line
14. drain hose
15. outdoor unit air outlet
16. Remote controls holder
17. Remote control
18. Ionizer (optional)
19. Air purifying filter
20. Electrostatic filter (optional)

# MODES OF OPERATION, FUNCTIONS AND FEATURES



**COOL** Cools, dehumidifies and filters the room air. Maintains desired room temperature.



**HEATING** Heats and filters the room air. Maintains the desired room temperature.



**AUTO** Automatically switches from COOLING to HEATING or from HEATING to COOLING, maintaining the desired temperature according to the room conditions.



**DRY** Dehumidifies and softly cools the room. In DRY Mode, the air conditioner operates at an increased dehumidifying power. This function is recommended to be used when temperature is rather low but the humidity is high.



**FAN** Recirculates and filters the room air. Maintains constant air movement in the room.



**AUTO FAN** The air conditioner automatically selects the FAN speed in accordance to the room temperature. At the start, the unit operates at high fan speed. As the room air approaches to the desired temperature, the fan switches automatically to a lower speed for quieter operation.

**HOT KEEP** In HEATING and in AUTO FAN, the fan will be turned off when the compressor is not in operation and will not be restarted, unless the indoor coil reaches adequate temperature. This HOT KEEP feature prevents uncomfortable cold air drafts. Use of AUTO FAN is, therefore, recommended when the air conditioner is in HEATING mode.



**I FEEL** Switches the temperature sensing point to the place where the remote control is located. (For general air conditioner, the temperature sensor is only located behind the air intake grille). This function is designed to provide a personalized by transmitting the temperature control command from the location Remote Control and the unit is done by infra-red signal. Therefore, in using next to you. The communication between the Remote Control and the unit is done by infra-red signal. Therefore, in using this function, the Remote Control should always be aimed , without obstructions at the air conditioner.



**TIMER** Real time control and display, automatically turns the air conditioner ON and OFF according to the time of day setting, ensuring comfort conditions before returning home, without wasting electricity. It turns the air conditioner off automatically when sleeping.



**SLEEP** Designed to create comfortable sleeping conditions. When in COOLING mode, the temperature rises one degree centigrade after each consecutive hour, for to three hours, from the start of the mode. The temperature rise prevents the feeling of over-cooling while sleeping (when your body is at rest). In HEATING mode the reverse occurs; the air conditioner lowers its temperature one-degree every hour. When in SLEEP mode, the air conditioner will be automatically turned off after have operated for seven hours. The result is a more comfortable and invigorating sleep, which leaves you feeling fresh and energetic on the next morning.

---

**AUTO FLAP** The air flap (louvers) is automatically positioned for the most suitable blow-out angle, when COOL, HEAT, DRY or FAN modes are selected. When the air conditioner is turned off, the flap will close automatically for an aesthetic appearance.

---

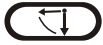

**Horizontal swing key** Auto swing and fixed direction is circle and modulators;When press key once,fan direction board will be automatic,press again and fan direction board will be fixed.It retains when mode is switchover.

---



**Vertical swing key (A1 & A2)** Vertical swing is controlled by 2 step motors A1 & A2. There are 7 kinds of modes:1) A1 & A2 at left together,2) A1 & A2 at left-middle together,3) A1 & A2 at middle together,4) A1 & A2 at right-middle together,5) A1 & A2 at right together,6) A1 at left and A2 at right,7) A1 & A2 auto swing.

---



**ROOM TEMPERATURE** Measures and displays room temperature.

---



**BUZZER** A soft buzzer will sound from the indoor unit display to indicate that a command sent by the remote control has been accepted and stored in the unit's memory. This feature may be easily cancelled by the user from the display panel.

---

**ON UNIT OPERATION** The air conditioner can be turned ON for COOLING or HEATING or be turned OFF directly from the indoor unit display panel without the use of the remote control.

---

**3-MIN DELAYED RUN** This compressor is protected by a three-minute delayed restart.

---

**LOCK** Freezes the last operation setting on the remote control. When LOCK is activated, the remote control will not be able to control the air-conditioner.

---

**MEMORY** The microprocessor retains the last data entry whether or not the unit is plugged in. Therefore, when the unit restarts after a power disruption or failure, it will resume operating in the same mode as before the power was disrupted.

---

**ELECTROSTATIC FILTER (optional)** They are capable of capturing small particles down to 0.1 microns, Such as atmospheric and house hold dust, coal dust, insecticide dust, mites, pollen, pet dander, tobacco smoke particles, cooking smoke and grease, mold fungi, bacteria, viruses and more.

---

**IONIZER (optional)** Ionizer make the air more fresh and more comfort. Slide switch (M) to the ON position and use the remote control to activate the ionizer. The blue light indicator (L) on the unit will light up indicating the ionizer in operation. To cancel the operation set slide switch to OFF position  
Important Notice: When the air-conditioner is turned OFF or if the indoor fan stops operation the IONIZER stops automatically.

---

# USE OF WIRELESS REMOTE CONTROL

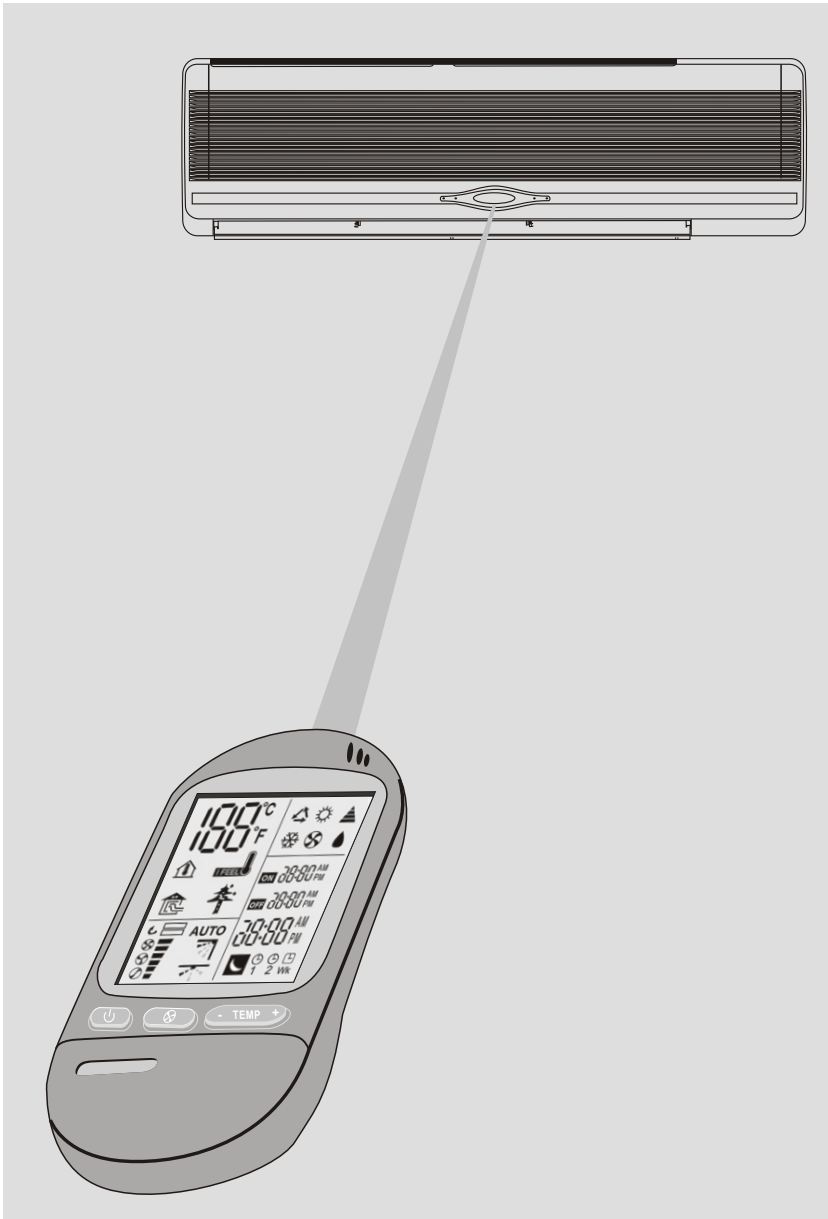

## PRIOR TO OPERATION

*Prior to operating your air conditioner, make sure that:*

- Insert the plug of indoor unit to power supply properly.
- Indicator (A) on air conditioner lights on, indicating air conditioner is ready to receive signals from remote control.
- The red tab protecting the remote control batteries has been removed.
- For clock setting, see page 11.

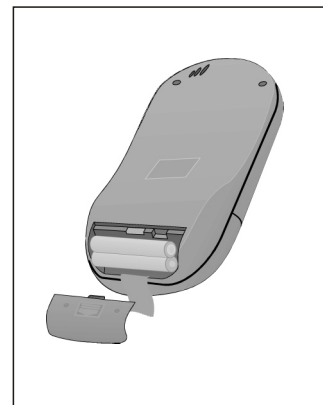

## WIRELESS REMOTE CONTROL PUTS ALL FUNCTIONS AT YOUR FINGERTIPS

- Aim at the infrared signal receiver on the room air conditioner when operating.
- The remote control signal can be received at a distance of up to about 8 m.
- Ensure that there are no obstructions between the remote control and the signal receptor.
- Do not drop or throw the remote control.
- Do not place the remote control in a location exposed to direct sunlight, or next to a heating unit, and/or other heat source.
- Do not expose the air conditioner signal receiver to a strong light such as fluorescent lamp or sunlight

## REMOTE CONTROL BATTERY CHANGE

- Remove the batteries from the remote control as shown.
- Use two 1.5 volt size AAA batteries
- For protecting the environment, please, return used batteries for recycling process.

## REMOTE CONTROL HOLDER

*Use the remote control holder when unit is not in use. Remote control can be slipped in or out its holder.*

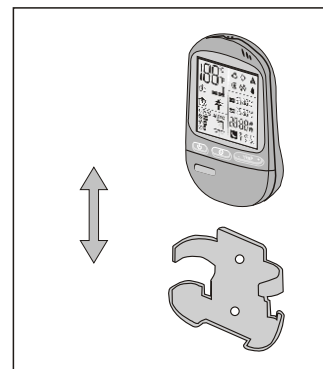

# ON-UNIT INDICATORS AND CONTROLS

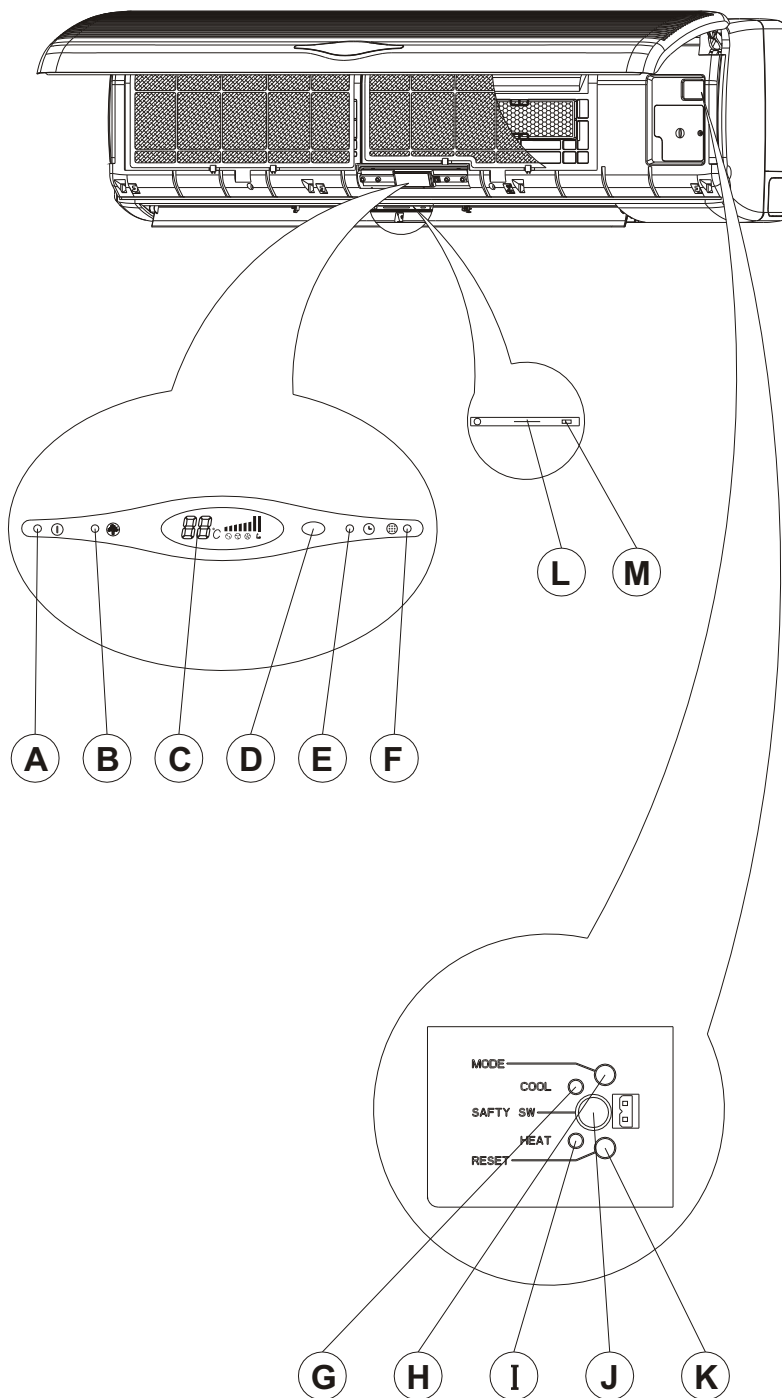

- A. Stand-by/Operation indicator  
*Lights up in red when connected to power.  
Lights up in blue during operation.*
- B. Fresh indicator  
*Lights up when the E.S.F or Ionizer operation.*
- C. LED display
- D. Signal receiver  
*Receiver signals from the remote control.*
- E. Timer indicator  
*Lights up during timer and sleep operation.*
- F. Filter indicator  
*Lights up when air filter requires cleaning.*
- G. Cooling indicator  
*Lights up only when mode (L) is pressed.*
- H. Unit mode button  
*Used to switch the unit for cooling or heating without the remote control.*
- I. Heating indicator  
*Lights up when mode (L) is pressed.*
- J. Electrostatic filter safety button  
*Turn off the Electrostatic filter when you open the grill.*
- K. Reset button  
*Press to turn off the filter indicator or cancel the buzzer announcer.*
- L. Ionizer indicator  
*Lights up during the ionizer is open.*
- M. Ionizer on/off  
*Used to switch the ionizer.*



# REMOTE CONTROL

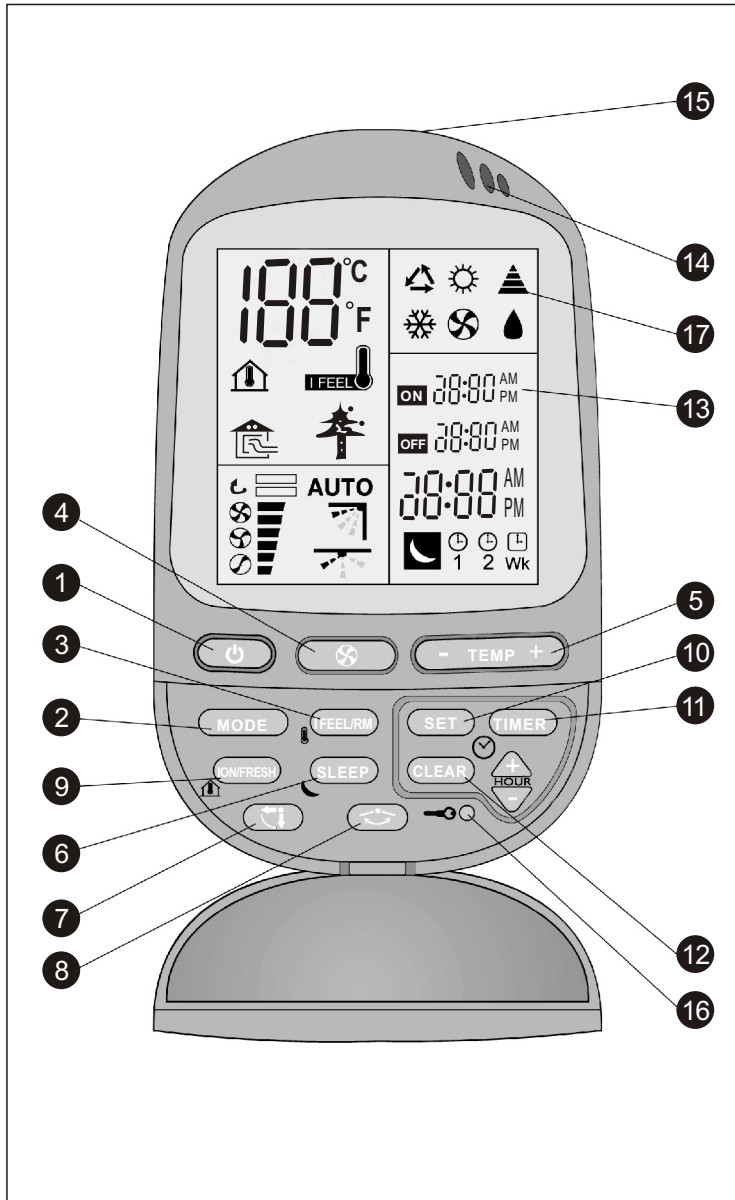

- ① ON/OFF button
- ② Operation mode selection button  
 AUTO  
 COOLING  
 HEATING  
 FAN  
 DRY
- ③ I FEEL temperature sensing and  
 Room temperature display button
- ④ FAN SPEED control button
- ⑤ Set point temperature UP and DOWN button
- ⑥ SLEEP button
- ⑦ Vertical swing button
- ⑧ Horizontal swing button
- ⑨ Ionizer and FRESH AIR button
- ⑩ TIME SET button
- ⑪ TIMER button
- ⑫ Clear button
- ⑬ LCD operation display
- ⑭ RM sensor
- ⑮ Infrared signal display
- ⑯ LOCK Button
- ⑰ Transmission sign

# OPERATION PROCEDURE

---

## TURNING ON THE AIR CONDITIONER

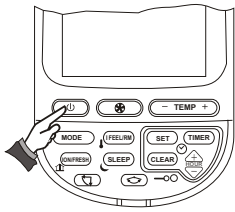

Press the START/STOP button (1) to turn on the air conditioner. After connecting to the power supply, The indicator (A) on the air conditioner light up, indicating that the air conditioner is in the standby status. Please note that LCD operation display (13) will always show the last mode of operation and the previous function used. If you want to change the control settings, proceed according to the following instructions. Otherwise, the air conditioner will start and operate in the same mode and functions prior to being turned off.

---

## VENTILATING OPERATION

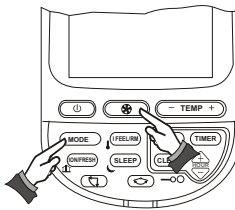

Select the ventilating mode by pressing MODE button (2). Switch to the desired fan speed by pressing FAN speed button (4).

---

## COOLING OPERATION

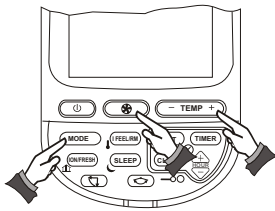

Select the COOLING mode by pressing MODE button (2). Switch to the desired FAN SPEED by pressing button (4). Select suitable temperature setting.

---

## COOLING OPERATION WITH AUTO FAN MODE

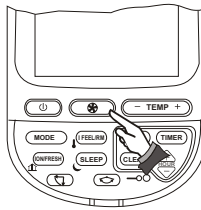

This operation starts with the highest air flow in order to quickly lower the room temperature. It will then automatically switch to the low air flow to quietly maintain the selected temperature.

---

## HEATING OPERATION

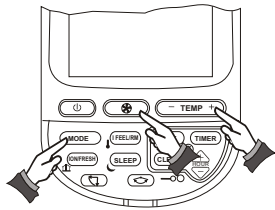

Select the HEATING mode by pressing MODE button (2). Switch to the desired FAN SPEED or to AUTO FAN by pressing FAN button (4). Select suitable temperature setting.

---

## HEATING OPERATION WITH AUTO FAN MODE

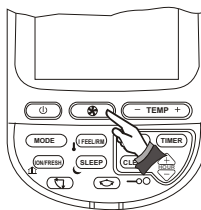

This operation starts with the highest air flow in order to quickly raise the room temperature. It will then automatically switch to a lower air flow to quietly maintain the selected temperature. HEATING with AUTO FAN will automatically provide the user with the HOT KEEP function. The fan will be turned off when the indoor coil temperature is not sufficiently hot to prevent uncomfortable cold air drafts.

---

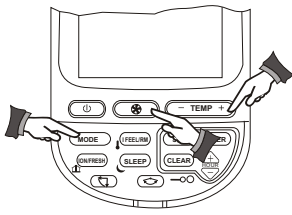

## AUTO COOLING/HEATING OPERATION

Select the AUTO mode by pressing MODE button (2). Switch to the desired FAN SPEED or to AUTO FAN by pressing button (4). Select suitable temperature setting. The air flap will automatically move to either horizontal air delivery for cooling or to vertical air delivery for heating. At start, the air conditioner will select its mode of operation according to the room temperature and the temperature setting.

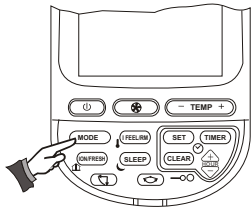

## DRY OPERATION

Select the DRY mode by pressing MODE button (2). Select the suitable temperature setting. While in DRY mode, the air conditioner will operate at low fan speed, regardless of the fan setting on the LCD operation display. Fan might terminate operation from time to time to prevent from over cooling.

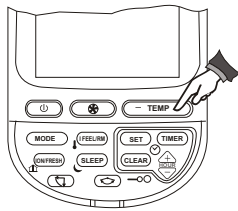

## SELECTING THE TEMPERATURE

Press TEMP button (5) to change the temperature setting in the LCD operation display(13).The temperature setting is shown in degrees centigrade. A higher number indicates a higher room temperature. A lower number indicates a lower room temperature.

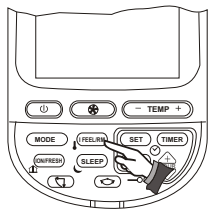

## I FEEL/ROOM TEMP FUNCTION OPERATION

Press button (3) to activate the I FEEL function. Thermometer sign will appear on the LCD operation display (13). Select suitable temperature setting. Make sure that the remote control unit is aimed at the air conditioner, with the I FEEL sensor (14) in front. Prevent the I FEEL sensor from being affected by heat sources such as lamps, heaters, direct sun, etc. or from being directly affected by the air conditioner air flow. These may cause the sensor to transmit the Wrong temperature data, thereby disturbing the performance of the I FEEL function.

By pressing on ROOM temperature, the measured room temperature and the room temperature sign will be displayed.

To cancel the ROOM Temperature display press on one of the following:

- Press again on ROOM temperature button (3).
- Change of MODE button (2)

Note: Room temperature range is between 0°C and 50°C in 1°C increments. Display should show "HI" or "LOW" to represent temperature that is above 50°C or below 1°C.

- Pressing on Temp set key  or 

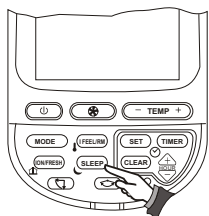

## SLEEP FUNCTION

Press the SLEEP button (6) to select the SLEEP function. When the sleep function is activated the air conditioner will be automatically turned OFF after seven hours. If at the same time TIMER is activated, as well ,the air conditioner will be turned ON and OFF according to the TIMER setting.

To cancel the SLEEP function press on one of the following:

- START/STOP button (1)
- SLEEP button (6)

## TIMER OPERATION

There are four timers that can be selected on the remote control. Two daily timers (designated as T1, T2), and two optional weekend timers (designated as WKT1, WKT2). Each timer can be selected by pressing TIMER button (11). To set each timer use time adjust up and down buttons Hour+(11) and Hour-(12) respectively. SET button (10) to enable the timer and/or CLEAR button (12) to disable the timer.

Indicator (c) on the air conditioner will light up during timer operation.

**NOTE:** After a power failure the timer operation is cancelled, timer indicator (c) on the air conditioner will blink, the unit will be automatically turned to stand-by mode and indicator (A) lights. To resume the timer operation, follow the instructions below.

### A. DAILY TIMER

The daily timers T1 and T2 can be set for ON and OFF separately for two different time periods. Once the timer is set it will resume operation when initiated.

### B. WEEKEND TIMER (OPTIONAL)

The weekend timers WKT1 and WKT2 can be set for ON and OFF separately for two different time periods for two days only.

It will be effective on the day of setting and on the day after only.

At 24:00 on the second day, the WK timer will not be effective anymore and the daily timer will resume its effectiveness.

WkT1-effective on the setting day

WKT2-effective one day after the setting day.

NOTE:

1. During the weekend timer operation, the daily timers will be disabled.
2. The WK timers must be reactivated before every weekend.

### C. SELECTING A TIMER

Press the TIMER button (11) to select a timer. Each time the TIMER button (11) is pressed, one of the four following timer icons will appear on the LCD display.

Press **TIMER** button to select daily timer **T1**.



Icon 1 of Timer **T1** will blink

Press **TIMER** button to select daily timer **T2**.



Icon 2 of Timer **T2** will blink

Press **TIMER** button to select weekend timer **WKT1**



Icons 1 and **WK** will blink

Press **TIMER** button to select weekend timer **WKT2**



Icons 1 and **WK** will blink

# TIMER OPERATING MODES

## SETTING THE **ON** TIMER

Undertake the following steps after selecting a timer-T1,T2 or WKT1,WKT2,to set a timer for the start time of operation.

**EXAMPLE:**  
Turning the air conditioner **ON** at 10:30.

Press the **SET**. button.



The **ON** icon & **ON** time digits will blink

Set the hours and minutes.



1. Set the **ON** time at 10:30  
2. Press the (HOUR+) up button to advance the time, and press the (HOUR-) down button to retract.

Press the **SET** button



1. The **ON** time is activated at 10:30 (the time **ON** icon will light)  
2. Time **OFF** icon & **OFF** time digits will blink.

Press the **CLEAR** button.



Timer **OFF** is cleared.

## SETTING THE **OFF** TIMER

Undertake the following steps after selecting a timer-T1,T2 or WKT1,WKT2,to set a timer for the stop time of operation.

**EXAMPLE:**  
Turning the air conditioner **OFF** at 18:30.

Press the **SET**. button.



The **ON** icon & **ON** time digits will blink.

Press the **CLEAR** button.



1. The **ON** time is cleared.  
2. **OFF** time icon & **OFF** time digits will blink.

Set the hours and minutes.



1. Set the **OFF** time at 18:30  
2. Press the (HOUR+) up button to advance the time, and press the (HOUR-) down button to retract.

Press the **SET** button



**OFF** time is activated at 18:30 (the (timer **OFF** icon will light)

### NOTES:

1. The default setting for the timers are 7:00 and 18:00 for **ON** and **OFF**, respectively.
2. The timer mode will display always the last **ON** and **OFF** settings on the LCD display

## SETTING THE ON AND OFF TIMERS

Undertake the following steps after selecting a timer-T1,T2 or WKT1,WKT2,to set a timer for the start and stop time of operation.

**EXAMPLE:**  
Turning the air conditioner ON at 10:30 and OFF at 18:30.

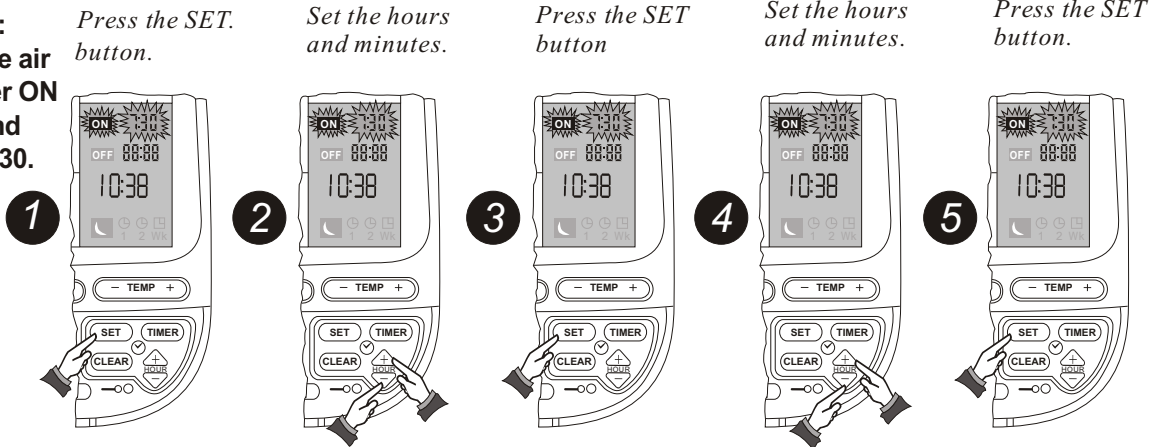

The ON icon & ON time digits will blink

1. Set the ON time at 10:30  
2. Press the (HOUR+) up button to advance the time, and press the (HOUR-) down button retract.

1. The ON time is activated at 10:30 (the time ON icon will light)  
2. Timer OFF icon & OFF time digits will blink.

1. Set the OFF time at 18:30  
2. Press the (HOUR+) up button to advance the time, and press the (HOUR-) down button retract.

OFF time is activated at 18:30 (the timer OFF icon will light)

## TO CHANGE THE TIME SETTING

**EXAMPLE:**  
To change the ON time setting from 10:30 to 9:20 (while preserving the OFF time setting)

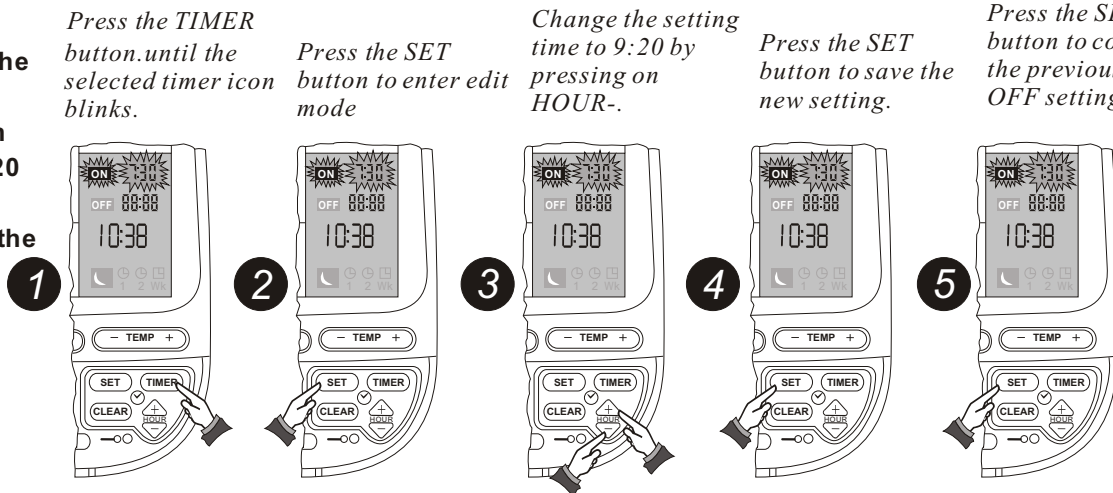

Note that the corresponding formerly set timer digits will display without blinking.

ON icon & ON time digits blink

ON icon & ON time digits blink

ON icon & ON time digits light while OFF icon & OFF time digits blink.

ON & OFF icons and time digits of the consequent timer light

## TO CANCEL THE TIMER SETTING FOR A PARTICULAR TIMER

To cancel the ON time while keeping the OFF time setting.

Press **TIMER** button to select a timer.

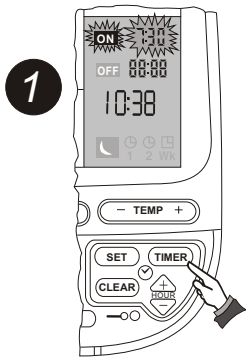

The selected timer icon blinks & the corresponding previous timer ON, OFF settings light.

Press **SET** button.



ON icon & ON time digits blink.

Press **CLEAR** button.



ON time is cleared, OFF icon & OFF time digits blink.

Press **SET** button

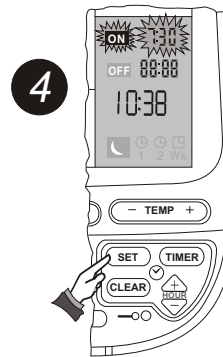

Confirm the new setting.

## TO CANCEL THE **ON** & **OFF** TIME SETTINGS

Press **TIMER** button to select a timer.

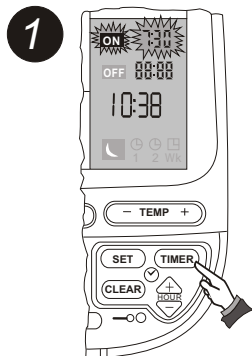

The selected timer icon blinks & the corresponding previous time ON, OFF settings light.

Press **CLEAR** button.



All settings of the selected timer are cleared.

### NOTES:

1. The default settings for the timers are 7:00 and 18:00, for ON and OFF respectively.
2. The timer mode will always display the last ON and OFF settings on the LCD display.
3. Pressing CLEAR button (12) for 5 seconds will cancel all timer settings and clear timer display.



## AIR FLOW VELOCITY AND DIRECTION ADJUSTMENT

Press button (7) to activate the supply air flap to auto swing;  
 Press button (8) to activate the Horizontal Air Flow to auto swing.  
 Press the two button again, you will cancel auto swing function.

To change the AIR FLOW velocity,press the button.

Each time the button is pressed,the fan speed is changed in sequence:

(Lo) → (Med) → (Hi) → (Strong) → (AUTO).

To change the AIR FLOW blowing direction vertically,press the button.

Each time the button is pressed,the angle of the HORIZONTAL VANE is changed in sequence:

- (1) → (2) → (3) → (4) → (5) → (SWING) → (AUTO).

To change the AIR FLOW blowing direction horizontally,press the button.

Each time the button is pressed,the angle of the VERTICAL VANE is changed in sequence:

→ → → → → → Swing

- 1) Strong fan will only operate in cooling & heating mode
- 2) Strong fan option is selectable via switch

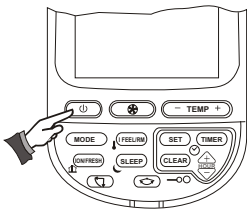

## TURNING OFF THE AIR CONDITIONER

Press On/Off button(1) to turn off the air conditioner. Indicator (A) on the air conditioner will be turned red. Indicating that the air conditioner is in Stand-by mode and ready to accept any new command from the remote control. The remote control LCD will display the clock time. The last operation set-up will kept for the next operation.

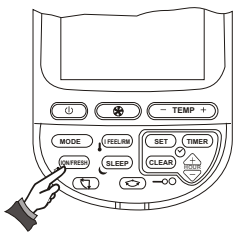

## Ionizer I Fresh Air operation.(optional)

Pressing the Ionizer I Fresh air key will cycle in the following manner:

Fresh air (continned) & Ionizer → Fresh air (continned) → Ionizer → off

Fresh air option is selectable via switch

The function will be kept when mode is switchover

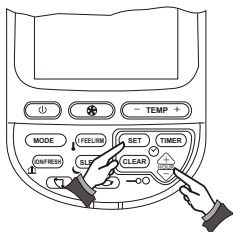

## CURRENT CLOCK TIME SET

Clock setting is performed when batteries are inserted.The remote control displays the setting and the clock display will blink 0:00 or 12:00 AM (AM sign will blink,too) till a new time is set.

For clock setting,use buttons and for setting the hours and minutes, respectively,and then press timer SET button (10).The clock setting can be also performed by pressing timer SET button (10) for 5 seconds.

The clock display will blink,for new setting follow the steps described above.

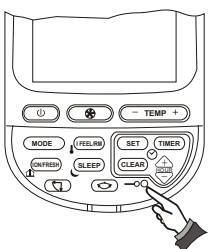

## LOCK FUNCTION

By pressing LOCK button (16),the remote control will lock the last operation program.All the function buttons will be inoperative,including START/STOP button.By pressing LOCK button (16) again the remote control will be released from its locked position.When lock mode is functioning,the transmission sign (17) will be on.



# PROTECTION MODES

Your air-conditioner includes several auto protection modes which enables you to use it virtually at any time and in any season regardless of the outdoor temperature. Some of the protection modes are listed below:

<b>Mode</b>	<b>Operation conditions</b>	<b>Protection from</b>	<b>Controlled remedy</b>
Cooling and Dry	Low outdoor temperature	Indoor coil freezes up	Stops outdoor fan and compressor when approaching freezing conditions Resumes operation automatically.
	High outdoor temperature	Outdoor coil overheating	Stop compressor when approaching over heating conditions. Resumes operation automatically. Operating indicator (A) blinks.
Heating	Low outdoor temperature	Outdoor coil ice build up	Reverses operation from heating to cooling for short periods to de-ice outdoor coil. Operating indicator (A) blinks.
	High Indoor or outdoor temperature	Indoor coil overheating	Stops outdoor fan and compressor when approaching high indoor coil temperature. Resumes operation automatically.

# CARE AND MAINTENANCE

---

Before performing any maintenance procedure, make sure to disconnect the air conditioner from the power.

---

## CLEANING THE AIR FILTER

- Your air conditioner is provided with a filter cleaning indicator. When the indicator (F)lights up, the filters should be removed for cleaning
  - To remove the air filters, lift up the panel. push the air filters up slightly to unlock them. pull out the filters, Clean the filter by washing in warm soapy water and dry thoroughly. align and fit the filters in place. close the panel by pushing it in the center to lock it in place.
  - Reset button ( K ) to turn off indicator ( F ).
- 

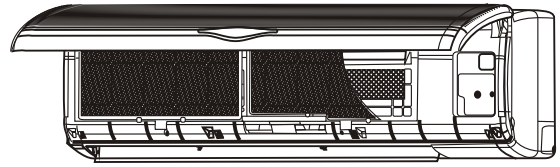

## CLEANING THE ELECTROSTATIC FILTER

- The electrostatic filter should be removed from the unit and cleaning once three month. The procedure is shown as following;
  - 1 open the front panel
  - 2 push the hook on the filter and pull out the electrostatic filter(Fig ①)
  - 3 wash the filter with the warm soapy water and dry thoroughly
  - 4 push the electrostatic filter into the right position
  - 5 close the front panel
- Note: the above procedure is used for cleaning the electrostatic filter.
- 

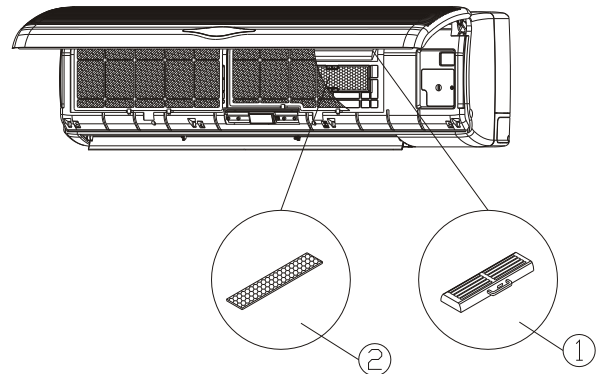

## PURIFICATION FILTER REPLACEMENT

- The air purifying filter should be removed from the unit and replaced once a year, show as following:
- 1 pulling out the filter(Fig ②)
- 2 replacing the filter in its place.

**DO NOT OPERATE THE UNIT WITHOUT FILTERS!**

---

## CLEANING THE AIR CONDITIONER

- Wipe the unit with a soft dry cloth or clean it using a vacuum cleaner
  - do not use hot water or volatile materials which could damage The surface of the air conditioner.
- 

## AT THE BEGINNING OF THE SEASON

- Make sure there are no obstacles blocking the flow of inlet or outlet air, in both indoor and outdoor units.
  - Make sure the power is properly connected.
- 

## PROTECT THE ELECTRONIC SYSTEM

- Indoor unit and remote control must be at least 1 meter away from a TV, radio or any other home electronic appliance.
  - Protect the inner unit from direct sun or lighting.
- 

## REMOTE CONTROL BATTERY CHANGE

- Remove the batteries from the remote control as show.
  - Use two 1.5 volt size AAA batteries.
- 



# OPERATING TIPS

- Set a suitable room temperature; excessively low room temperature is not good for your health and wastes electricity. Avoid frequent setting of the temperature.
- During cooling, avoid direct sun. Keep curtains and blinds closed. Close doors and windows to keep the cool air in the room.
- Avoid generating heat or using of heating appliances while the air conditioner in cooling mode.
- Make sure that the air flap is positioned properly: horizontal flow in cooling and downward vertical flow for heating.
- Keep the room temperature uniform by adjusting the Left/Right vertical air blades.
- Position the air flap and the left/right air blades in such a manner as to prevent your body from being exposed directly to air drafts.
- During prolonged operation, ventilate the room occasionally by opening a window from time to time.
- In a power failure, the microprocessor memory is retained. When restarted, operation will be resumed in the last mode of operation. However, if the timer was used, the unit will be turned off by the timer only if the remote control is aimed at the unit. Otherwise the power failure will cause the timer data to be erased from the microprocessor memory.
- After turning on, allow more than 3 minutes for cooling, heating or dry operation to start.
- When Dry mode is used, make sure that the room temperature is between 20° to 27°C. When used out of this range, the unit may protect itself and become inoperative.
- When COOL or DRY modes are used, make sure that the room's relative humidity is below 78%. If the unit is used for a prolonged periods of time in high humidity, moisture may form on the air outlet and drip down.
- Remote control signals may not be received if the indoor unit controls cover is exposed to direct sunlight or strong light. In such a case, block the sunlight or dim the lighting.
- The remote control is operative in a range of 8 meters. If you are out of range, the remote control may have difficulties in transmitting signals.

# PRECAUTIONS

- Use the proper electrical fuse..

Do not pull out the power cord unless the unit is turned off.

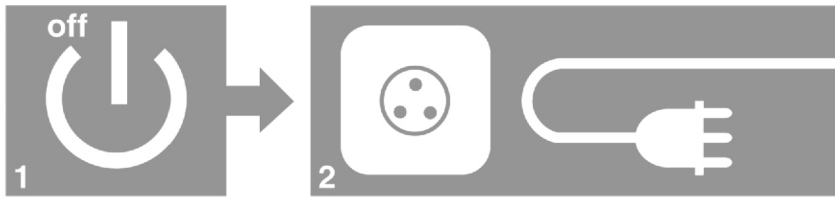

Do not turn on or off air conditioner by inserting the power cord.

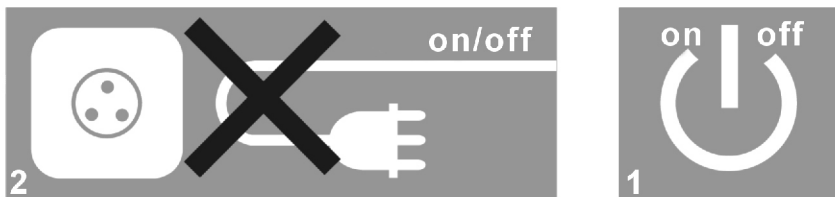

Do not obstruct or block the air inlet or air outlet of the air conditioner.

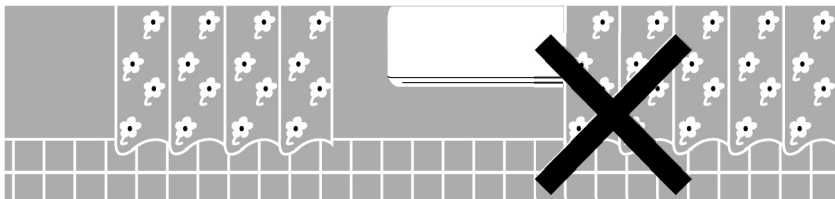

Do not insert any objects in the air outlet of the indoor or outdoor unit.



Do not splash water on air conditioner.

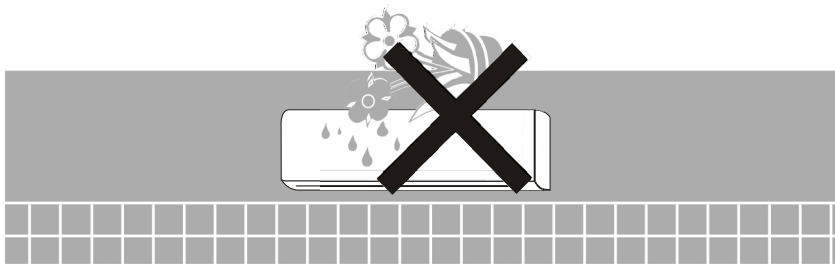

## IF NOISE IS HEARD

There may be hissing sound during operation or just after shut down. This is caused by the refrigerant that is circulating inside the unit

There may be a cracking sound at starting and stopping the unit's operation. This is caused by heat expansion or contraction of plastics.

# BEFORE CALLING FOR SERVICE

Before calling for service, please check the following common malfunctions and correct it as needed.

Problem	Cause	Remedy
<ul style="list-style-type: none"> <li>Unit does not operate. Standby indicator does not light up.</li> </ul>	<ul style="list-style-type: none"> <li>Unit not connected to power</li> <li>Power failure</li> </ul>	<ul style="list-style-type: none"> <li>Plug in the power cord.</li> <li>Check main fuse.</li> </ul>
<ul style="list-style-type: none"> <li>Unit does not operate. Standby indicator lights.</li> </ul>	<ul style="list-style-type: none"> <li>Remote control malfunctions</li> <li>The remote control is locked.</li> </ul>	<ul style="list-style-type: none"> <li>Check remote control batteries.</li> <li>Try to operate from a closer distance.</li> <li>Start from on-unit controls.</li> <li>Perform reset operation by pressing buttons: (7) (8) for 5 sec.</li> <li>Unlock the remote control.</li> </ul>
<ul style="list-style-type: none"> <li>Unit does not respond properly to remote control command.</li> </ul>	<ul style="list-style-type: none"> <li>IR signal does not reach unit.</li> <li>Distance between remote control and unit too large or aimed at from improper angle.</li> <li>IR receiver on-unit exposed to strong light source.</li> </ul>	<ul style="list-style-type: none"> <li>Check for obstruction between unit and remote control, Clear if needed.</li> <li>Get closer to unit.</li> <li>Dim lights, fluorescents especially</li> </ul>
<ul style="list-style-type: none"> <li>Air does not blow out from indoor unit.</li> </ul>	<ul style="list-style-type: none"> <li>De-icing protection mode is activated.</li> <li>Unit is in AUTO FAN mode.</li> <li>Over cooling in DRY.</li> </ul>	<ul style="list-style-type: none"> <li>Normal operation in HEATING mode.</li> <li>Normal operation in DRY mode.</li> </ul>
<ul style="list-style-type: none"> <li>COOLING, DRY or HEATING does not start immediately.</li> </ul>	<ul style="list-style-type: none"> <li>3-min. Compressor delay start.</li> </ul>	<ul style="list-style-type: none"> <li>Normal operation for these modes.</li> </ul>
<ul style="list-style-type: none"> <li>Unit functions but does not perform sufficiently.</li> </ul>	<ul style="list-style-type: none"> <li>Improper temperature setting.</li> <li>Unit capacity insufficient for load or room size.</li> </ul>	<ul style="list-style-type: none"> <li>Reset temperature.</li> <li>Consult your dealer.</li> </ul>

## **INSTALLATION INSTRUCTIONS**







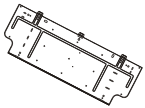

---

1. ACCESSOIRES SUPPLIED WITH AIR CONDITIONER
2. LOCATION OF INDOOR AND OUTDOOR UNITS
3. ELECTRICAL REQUIREMENTS
4. INSTALLATION OF THE INDOOR UNIT
5. CONDENSATE HOSE CONNECTION
6. ELECTRICAL CONNECTIONS BETWEEN INDOOR AND OUTDOOR UNITS
7. REFRIGERANT TUBING
8. FINAL TASKS

The appliance shall not be installed in the laundry

# 1

## ACCESSORIES SUPPLIED WITH THE AIR CONDITIONER

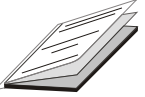
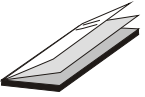
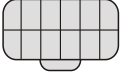
Shape	Name	Qty	Used for
	Mounting rail	1	Wall mounting of indoor unit
	Remote control with batteries	1	Operation of unit
	Remote control bracket	1	Wall mounting of remote control
	Screws washers Dowels	8	Wall mounting of indoor unit
	Screws, Dowels	2	Wall mounting of the remote control bracket
	Outdoor unit drain connector	1	Outdoor unit water drain
	Mounting pads	4	Padding of outdoor unit bottom supports
	Cable ties	4	Securing wires in the indoor and outdoor unit
	Cable terminals	2	Securing of grounding wire on the indoor and outdoor unit
	Operation instructions	1	Users' reference
	Installation instructions and template	1	Installers' reference
	Air purifying filter (optional)	1	Cleaning the air

# 2

## LOCATION OF INDOOR AND OUTDOOR UNITS

Select the location considering the following:

### INDOOR UNIT

1. Choose a location which will provide good air circulation. Ensure that no objects or furnishings prevent air circulation.
2. Do not install the unit near a heat source or where it will be exposed to direct sunlight.
3. The location must allow convenient electrical drainage and tubing connections.
4. Installation site should provide an easy passage to outdoors.
5. The unit must be mounted on a strong wall that will withstand vibration-generated noise.
6. Install the mounting plate as shown.

### OUTDOOR UNIT

1. The location must allow easy servicing and provide good air circulation.
2. The unit may be suspended from a wall by a bracket (Optional) or located in a free standing position on the floor (preferably slightly elevated).
3. Before the unit is suspended, ensure that the bracket is firmly connected and the wall is strong enough to withstand vibrations.
4. Unit location should not disturb neighbors with noise or exhaust air stream.
5. Place the mounting pads under the unit legs.
6. Install the outdoor unit as shown. Refer to the technical and service manual for allowed distances.
7. When the unit is installed on a wall, install the drain connector hose as shown.

**Fig.1**

1. Bottom of outdoor unit
2. Drain connector

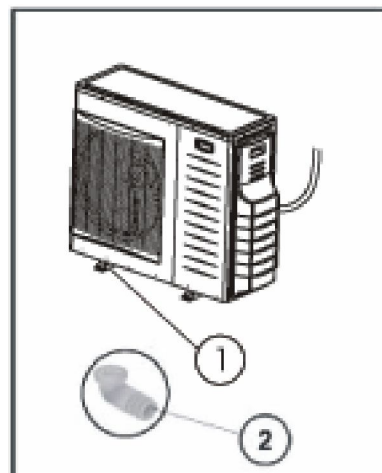

**Fig.2**

1. Drain installation
2. Example

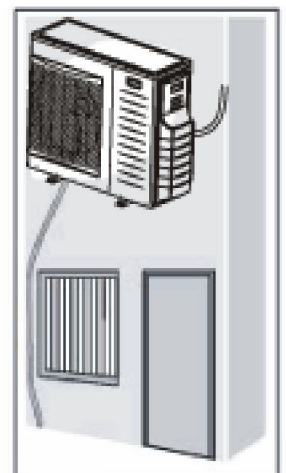
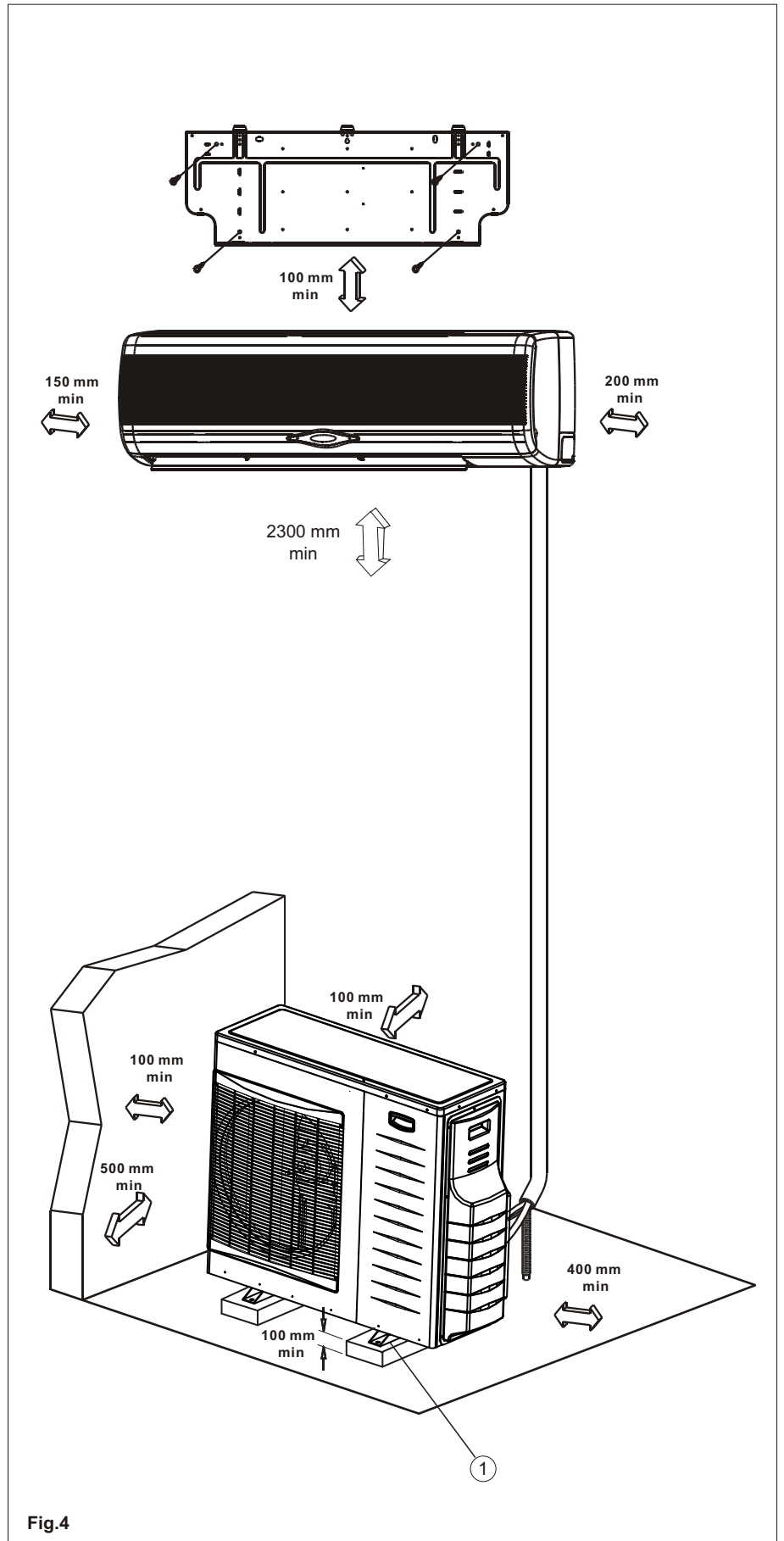
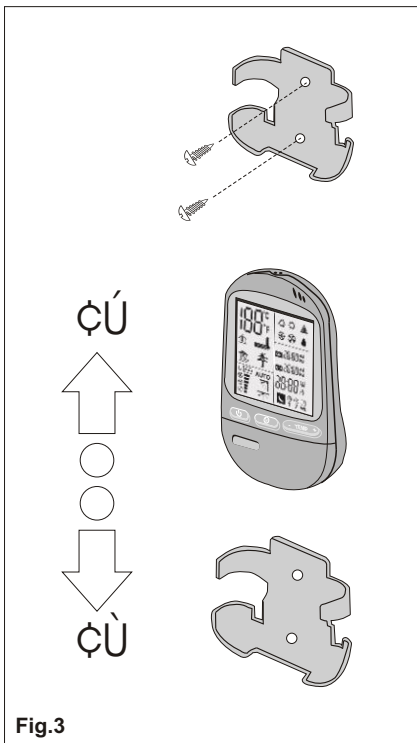

Fig.3  
 1. To attach  
 2. To remove





# 3

Electrical wiring and connections should be made by qualified electricians and in accordance with local electrical codes and regulations. The air conditioner units must be grounded.

The air conditioner unit must be connected to an adequate power outlet from a separate branch circuit protected by a time delay circuit breaker, as specified on unit's nameplate.

Voltage should not vary beyond  $\pm 10\%$  of the rated voltage.

# 4

## INSTALLATION OF THE INDOOR UNIT

### REMOVAL AND INSTALLATION OF THE FRONT PANEL

1. Open the front panel.
2. Place the horizontal deflection louvers in a horizontal position.
3. Open the screw caps on the panel front.
4. Unscrew the screws to release the front panel.
5. Remove the front panel by lifting it in the direction indicated by arrows.
6. After installation of the indoor unit, reinstall the front panel. Place the top end of the panel onto the top end of the indoor unit, press on the upper part of the panel, and at the same time push the bottom toward the indoor unit.
7. Replace the screws and their caps.

- Fig.5
1. Lift front panel
  2. Screw caps
  3. Screw
  4. Horizontal deflection levers
  5. Screws
  6. Front panel

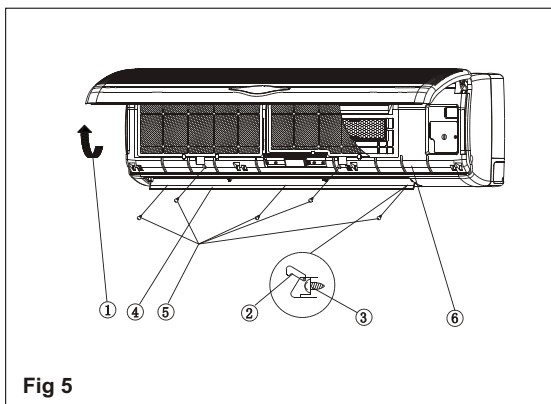

### REFRIGERATION TUBE ROUTING

1. There are five possible routes for installing the refrigeration tube as shown.
2. For route (6), cut the bottom notch in the rear.
3. For routes (5) or (7), cut the side notches in the rear and in the front panel.

- Fig.6
- |                |                        |
|----------------|------------------------|
| 1. Front       | 4. Lefthand outlet     |
| 2. Rear        | 5. Lefthand rar outlet |
| 3. Rear outlet | 6. Bottom outlet       |
|                | 7. Righthand outlet    |

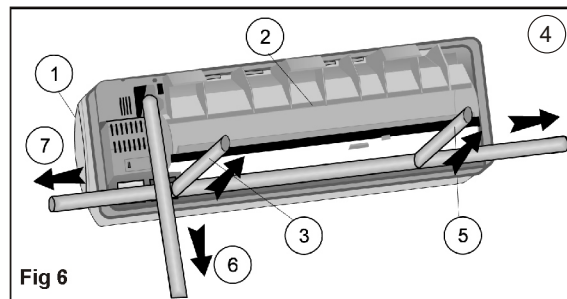

### INSTALLATION OF THE MOUNTING PLATE

1. Figure 7 shows the location of the mounting plate relative to the unit size. Refer to one of the drawings, according to your unit length (marked in square).
2. Locate the mounting plate as shown on the wall in a horizontal position, using a spirit level.
3. Mark the position of the four mounting holes on the wall and drill four holes to accommodate the dowels.
4. Mount the mounting plate on to the wall by the four screws. Ensure screws are tightened properly.

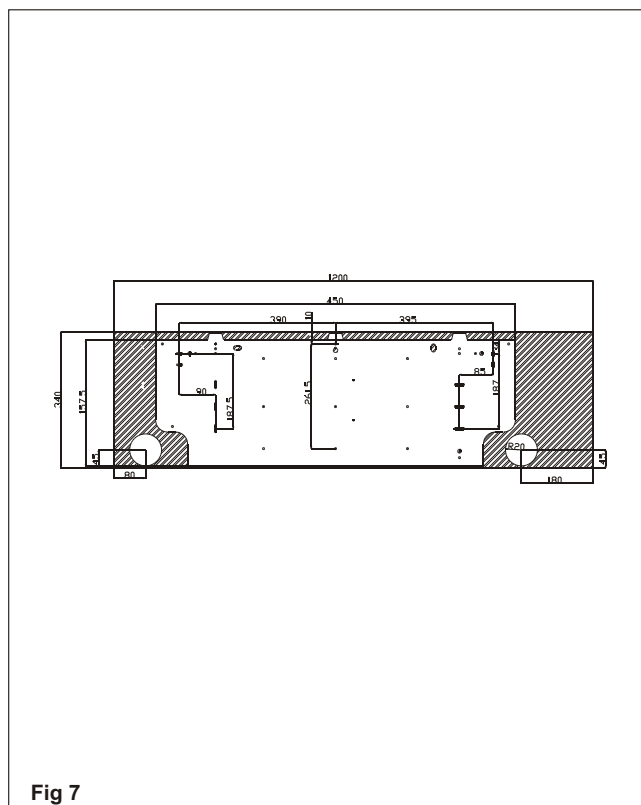

## PENETRATION OF WALL FOR TUBING

1. Mark the location of the hole on either side of the mounting plate as shown. and drill it at a 5° downward angle, as shown.
2. The hole is drilled at an angle, to prevent condensed or rain water from penetrating back into the room
3. Trim the hole in the wall with a  $\varnothing 70$  mm commercial plastic tube.

Fig. 8

A. OUTDOOR SIDE 1. Drill  $\varnothing 70$  mm  
B. INDOOR SIDE 2. Wall

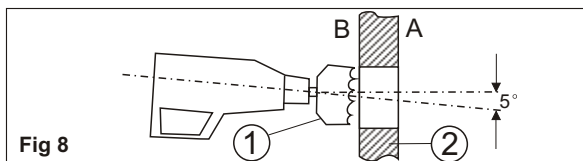

## SUSPENDING AND RELEASING THE UNIT FROM THE MOUNTING PLATE

1. Make sure that the refrigerant tubes, electric cables and condensate water hose are well insulated with closed cell rubber based insulating tubes (6 mm thickness), are wrapped together with UV stabilized non-adhesive plastic tape, and are passed through the hole in the wall.
2. Hang the indoor unit on the two hooks that are located near the top edge of the mounting plate.
3. Press the lower part of the indoor unit against the mounting plate until the catches snap into the slots and lock the indoor unit to the mounting plate.
4. Check the installation by pulling the unit towards you.
5. To release the unit from the mounting plate, lift up the unit and then pull the unit towards you, to ensure that the hooks are locked.

Fig.9

1. Indoor unit 3. Top hooks  
2. Snap catches 4. Bottom hooks

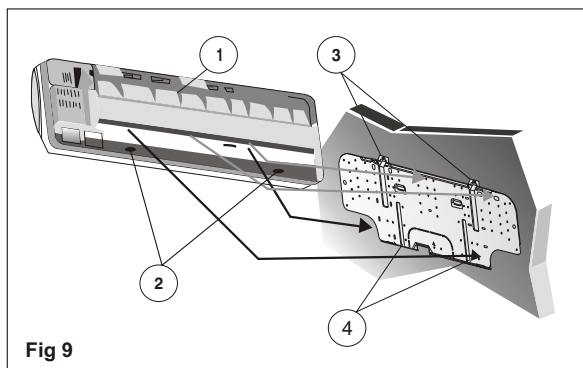
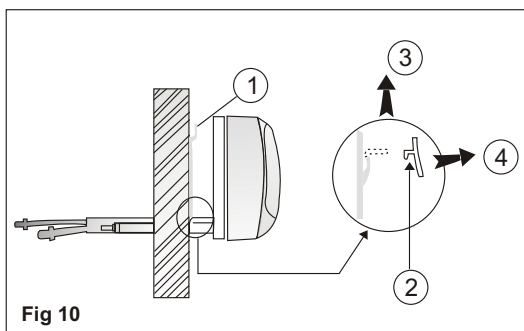

Fig.10

1. Mounting plate 3. Lift up  
2. Lower hook 4. Pull



## CONDENSATE HOSE CONNECTION

1. Attach the condensate drain hose to the corrugated hose in the rear groove of the indoor unit.

Fig.11

1. Drain hose  
2. Clamp  
3. Downward slope

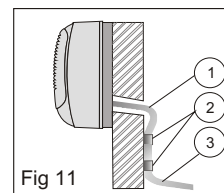

2. Wrap the drain hose together with the refrigerant tubes and electrical cables.

3. Ensure that the condensate drain hose is installed at all points in a downward slope manner.

Fig.12

1. Trap  
2. U-bend  
3. End immersed in water

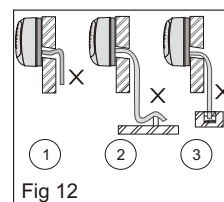

4. When installing the drain hose avoid traps and U-bends. The end of the drain hose should not be immersed in water.

Fig.13

1. Electric cable  
2. Refrigerant tubing  
3. Condensate drain hose

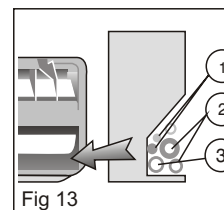

5. For a lefthand outlet, lay the drain hose on the bottom of the indoor unit rear groove.

Fig.14

1. Vent  
2. Downward drain  
3. Water drain hose

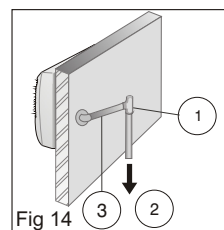

6. When the installation location requires long horizontal sections, a vent must be provided at the top of the hose to prevent overflow of the unit drain pan.

7. Upon completing the installation, test the water drain by pouring at least two liters of water into the unit drainpan. Check that the water drains off.

## ELECTRICAL CONNECTIONS BETWEEN INDOOR AND OUTDOOR UNITS

- To connect the indoor unit with the outdoor unit use the following electrical cables, protected for outdoor use:

### SINGLE PHASE MODELS (see Fig. 16)

#### Cooling and heating model:

Model	Maximum Current	Circuit Breaker
XLM 30	19 A	25 A
XLM 36	25 A	32 A

#### Important:

Wire size should be according to local electrical codes and regulation

#### Twin wire cable:

2 wires x 0.5 mm<sup>2</sup> - For low voltage.

#### For units above 8 KW (see fig.16)

The main power supply (5) will be connected to the outdoor unit.

- Prepare inter-unit cable ends for connections.
- Connect the cable ends to the terminals of the indoor and outdoor units, as shown in Fig. 16.  
Be sure to match the colored wires with the numbers shown on the indoor and outdoor unit terminal boards.
- Connect the yellow/green ground wire to the ground terminal screw.
- Secure multiple wire power cable with the cable clamps.
- Fasten the twin wire cable to the power cable with cable ties.

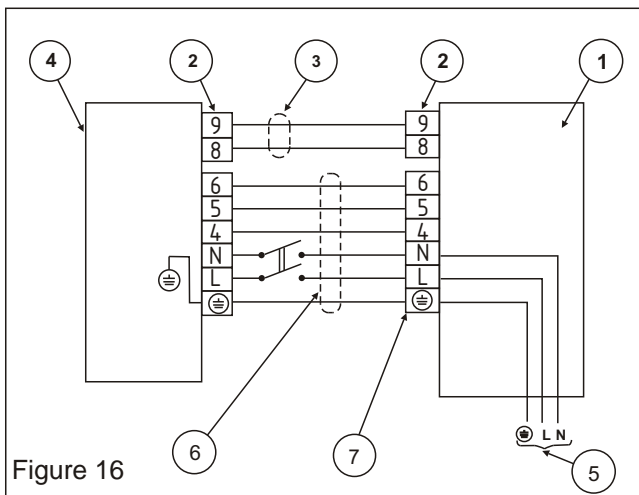

Figure 16

- Fig. 16
- Outdoor unit
  - Terminal board
  - Control cable
  - Indoor unit
  - Power supply
  - Electrical interconnecting cable
  - Terminal board male/female

Fig.15

- Terminals
- Cover
- Cable tie

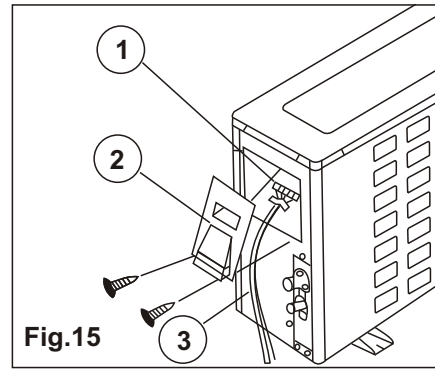

Fig.15

#### NOTES:

- The wire color codes can be selected by the installer.
- Wires leading to terminals 8 and 9 must be in a separate twin wire cable, otherwise the electronic controls will be subject to operational malfunctions.
- For cooling only model, Wire (5) should not be connected to terminal No.5.
- In some models the twin wire cable is factory-connected to the indoor unit.

## CONNECT THE INDOOR TO THE OUTDOOR UNIT

The indoor unit contains a small quantity of Helium. Do not unscrew the nuts from the unit until you are ready to connect the tubing. The outdoor unit is supplied with sufficient refrigerant charge for a 6 m tubing length. For additional charge, please refer to outdoor unit nameplate.

To prevent crushing, bend tubes using a bending tool.

**NOTE:** Use refrigeration type copper tubing only.

1. Use tubing diameter that corresponds to the tubing diameter of the indoor and outdoor units. Note that the liquid and suction tubes have different diameters. (See tube size, torque tightening table.)
2. Place flare nuts on tube ends before preparing them with a flaring tool. Use the flare nuts that are mounted on the supplied outdoor and indoor units.
3. Connect the four ends of the tubing to the indoor and outdoor units.
4. Insulate each tube separately, and their unions, with at least 6 mm of insulation. Wrap the refrigerant tubing, drain hose and electric cables together with a vinyl tape (UV protected).

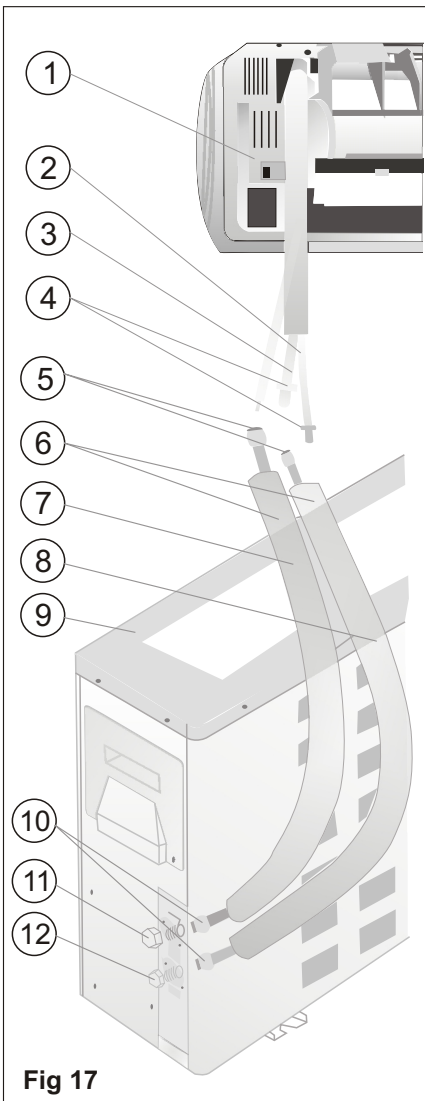

**Caution!**  
When unscrewing the valve caps, do not stand in front of them or the spindles at any time, as the system is under pressure.

**Fig. 17**  
1. INDOOR UNIT  
2. Liquid tube (small dia.)  
3. Suction tube (large dia.)  
4. Plugs  
5. Flare nuts  
6. Tubing insulation  
7. Suction tube  
8. Liquid tube  
9. OUTDOOR UNIT  
10. Flare nuts  
11. Suction valve (larger)  
12. Liquid valve (small)

### Tightening torques of unions and valve caps:

TUBE SIZE	TORQUE
Liquid line 3/8"	30-35 N.M.
Suction line 1/2"	50-54 N.M.
Suction line 5/8"	75-78 N.M.
Suction line 3/4"	80-100 N.M.

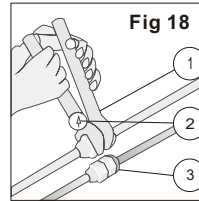

**Fig. 18**  
1. Wrench  
2. Torque wrench  
3. Union

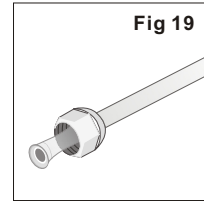

**Fig. 19**  
To prevent refrigerant leakage, coat the flared surface with refrigeration oil

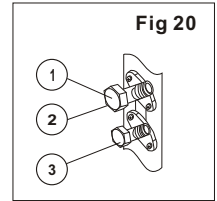

**Fig. 20**  
1. Suction valve  
2. Service port  
3. Liquid valve

After connecting the unions of the indoor and outdoor units, purge the air from the tubes and indoor unit as follows:

1. Connect the charging hoses with a push pin to the low and high sides of the charging set and the service port of the suction and liquid valves. Be sure to connect the end of the charging hose with the push pin to the service port.
2. Connect the center hose of the charging set to a vacuum pump.
3. Turn on the power switch of the vacuum pump and make sure that the needle in the gauge moves from 0 Mpa (0cm Hg) to -0.1 MPa (-76cm Hg). Let the pump run for fifteen minutes.
4. Close the valves of both the low and high sides of the charging set and turn off the vacuum pump. Note that the needle in the gauge should not move after approximately five minutes.
5. Disconnect the charging hose from the vacuum pump and from the service ports of the suction and liquid valves.
6. Tighten the service port caps of both suction and liquid valves.
7. Remove the valve caps from both valves, and open them using a hexagonal Allen wrench.
8. Remount valve caps onto both of the valves.
9. Check for gas leaks from the four unions and from the valve caps. Test with electronic leak detector or with a sponge immersed in soapy water for bubbles.

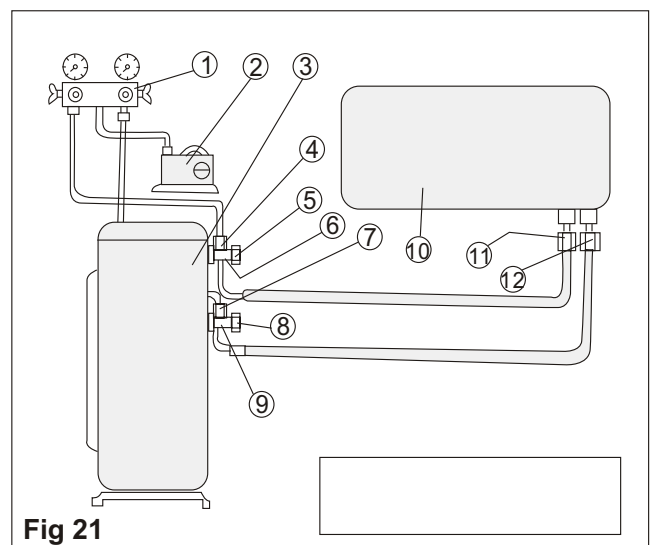

**Fig. 21**  
1. Charging set  
2. Vacuum pump  
3. OUTDOOR UNIT  
4. Service valve  
5. Cap  
6. Suction valve  
7. Service valve\*  
8. Cap  
9. Liquid valve  
10. INDOOR UNIT  
11. Suction flare connection  
12. Liquid flare connection  
\*In some models only

# 8

## RESTRICTOR INSTALLATION

THIS INDOOR UNIT IS SUPPLIED WITH AN EXTRA INSTALLATION FOR CONNECTION TO THE INDOOR LIQUID TUBE DURING INSTALLATION. WITHOUT THIS KIT THE UNIT WILL NOT OPERATE PROPERLY IN THE HEATING MODE. (See Fig. 22)

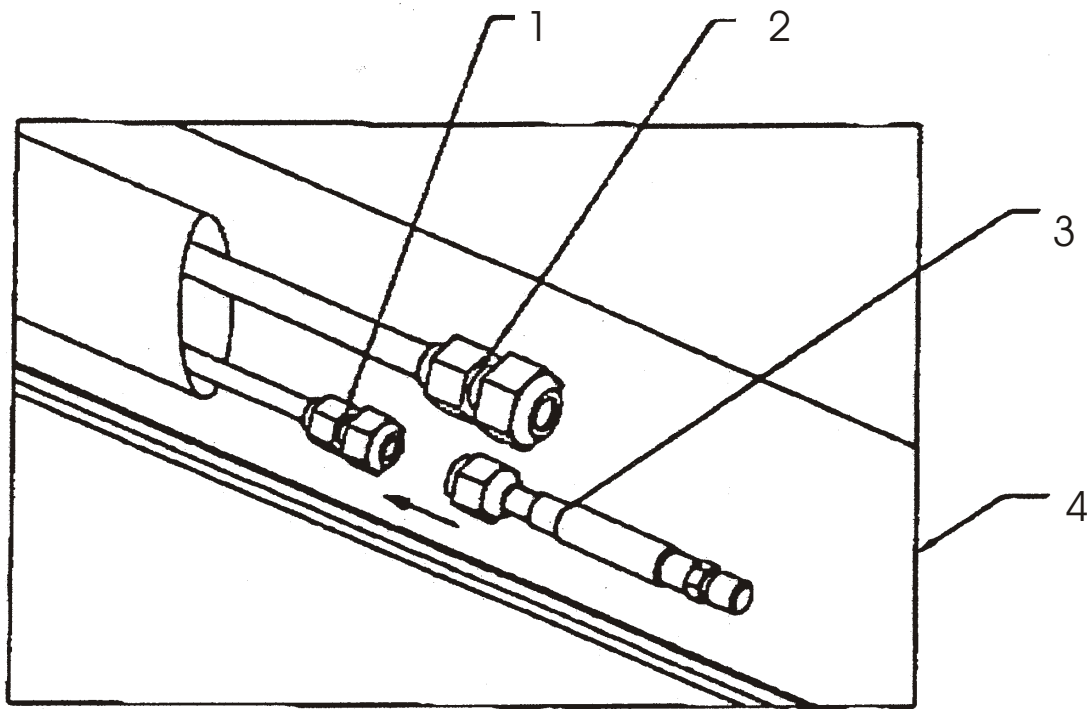

Fig.22

- 1. LIQUID TUBE
- 2. SUCTION TUBE
- 3. RESTRICTOR
- 4. INDOOR UNIT

# 9

## FINAL TASKS

1. Replace all valve caps and ensure that they are tightened properly.
2. Fill gaps on the wall between hole sides and tubing with sealer.
3. Attach wiring and tubing to the wall with clamps where necessary.
4. Operate the air conditioner togetherwith the customer and explain all functions.
5. Explain filter removal, cleaning and installation.
6. Give the operating and installation manuals to the customer.



## TECHNICAL ENQUIRIES

**1800 1800 04**

## SERVICE / WARRANTY

**1300 553 000**

### MELBOURNE

---

745 Springvale Road  
Mulgrave VIC 3170

TEL: (03) 9271 3505

FAX: (03) 9271 3540

### SYDNEY

---

CNR Marion St & Airport Ave  
(P.O. Box. VQ)Banktown  
Airport NSW 2200

TEL: (02) 9793 3644

FAX: (02) 9793 3688

### BRISBANE

---

Unit 9, 123 Muriel Ave  
Moorooka QLD 4105

TEL: (07) 3392 8113

FAX: (07) 3392 8115

### ADELAIDE

---

Offices on the park Suite 27, 8  
Greenhill Road  
Wayville SA 5034

TEL: (08) 8372 7866

FAX: (08) 8372 7816

### PERTH

---

Suite 23, 350 Cambridge St  
Wembley WA 6014

TEL: (08) 9284 0800

FAX: (08) 9284 0600

### NEWCASTLE

---

Suite 3, 19 Darby Street  
Newcastle NSW 2300

TEL: (02) 4940 4652

FAX: (02) 4940 4653

### NEW ZEALAND

---

517A Rosebank Road  
Avondale, Auckland NZ

TEL: (09) 820 0333

FAX: (09) 820 0332

NZ Tech Support Freecall

TEL: 0800 180 094

[www.airwell.com.au](http://www.airwell.com.au)