

*Airwell*

# Service Manual

## Multi Splits Series

HKD Indoor Units	HND Indoor Units	CBD Indoor Units	XAD Indoor Units	DCD Indoor Units	Outdoor Units
AWSI-HKD009-N11	AWSI-HND009-N11				AWAU-YCZ218-H11
AWSI-HKD012-N11	AWSI-HND012-N11	AWSI-CBD012-N11	AWSI-XAD012-N11	AWSI-DCD012-N11	AWAU-YCZ327-H11
AWSI-HKD018-N11	AWSI-HND018-N11				AWAU-YCZ430-H11
					AWAU-YCZ536-H11

**REFRIGERANT**

**R410A**

**SM YCZ DCI 1-A.1 GB**

**HEATPUMP**

**AUG 2014**

---

<b>Part 1 General Information .....</b>	<b>1</b>
<b>Part 2 Indoor Units .....</b>	<b>11</b>
<b>Part 3 Outdoor Units.....</b>	<b>53</b>
<b>Part 4 Installation.....</b>	<b>74</b>
<b>Part 5 Electrical Control System .....</b>	<b>85</b>

※The specifications, designs, and information in this book are subject to change without notice for product improvement.

# Part 1

## General Information

1. Model Lists.....	2
2. External Appearance .....	3
2.1 Indoor Units .....	3
2.2 Outdoor Units .....	3
3. Product specification .....	4

## 1. Model Lists

### 1.1 Indoor Units

<b>Cooling &amp; Heating</b>			
<b>Indoor units type</b>	<b>Indoor units model</b>	<b>Capacity(Btu/h)</b>	<b>Power supply</b>
HKD indoor	AWSI-HKD009-N11	9000	220-240V 50Hz 1Ph
	AWSI-HKD012-N11	12000	220-240V 50Hz 1Ph
	AWSI-HKD018-N11	18000	220-240V 50Hz 1Ph
HND indoor	AWSI-HND009-N11	9000	220-240V 50Hz 1Ph
	AWSI-HND012-N11	12000	220-240V 50Hz 1Ph
	AWSI-HND018-N11	18000	220-240V 50Hz 1Ph
Four-way cassette(compact)	AWSI-CBD012-N11	12000	220-240V 50Hz 1Ph
Duct	AWSI-DCD012-N11	12000	220-240V 50Hz 1Ph
Console	AWSI-XAD012-N11	12000	220-240V 50Hz 1Ph

### 1.2 Outdoor Units

<b>Universal Outdoor unit Model</b>	<b>Compressor type</b>	<b>Compressor Brand</b>	<b>Power supply</b>
AWAU-YCZ218-H11	Twin-rotary	GMCC	220-240V 50Hz 1Ph
AWAU-YCZ327-H11	Twin-rotary	GMCC	220-240V 50Hz 1Ph
AWAU-YCZ430-H11	Twin-rotary	GMCC	220-240V 50Hz 1Ph
AWAU-YCZ536-H11	Twin-rotary	MITSUBISHI	220-240V 50Hz 1Ph

## 2. External Appearance

### 2.1 Indoor Units

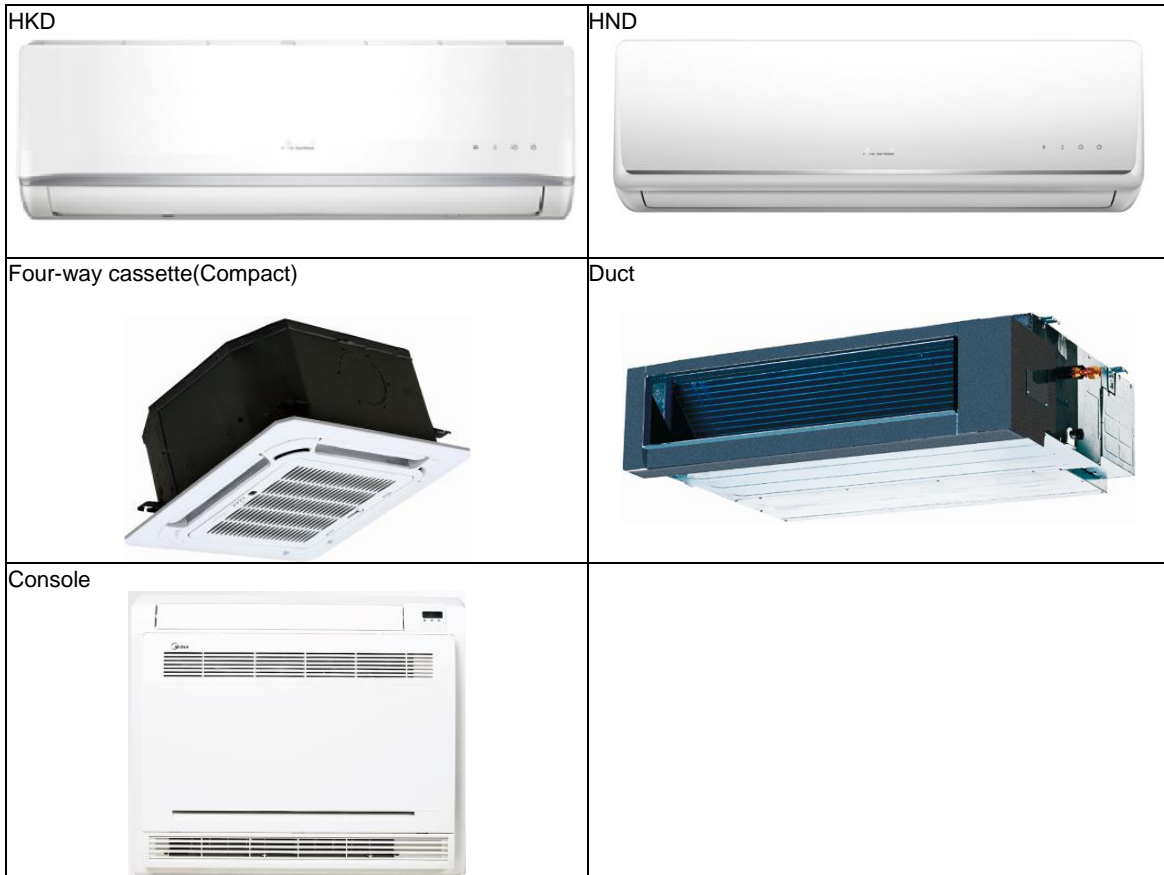

### 2.2 Outdoor Units



### 3. Product specification

Model Outdoor Unit		AWAU-YCZ218-H11				
Installation Method of Pipe		2 x AWSI-HND009-N11	2 x AWSI-HKD009-N11			
Installation Method of Pipe		Flared		Flared		
Characteristics	Units	Cooling	Heating	Cooling	Heating	
			Average		Average	
Capacity <sup>(1)</sup>	kW	5.2	6	5.2	6	
Pdesign	kW	5.2	5.9	5.2	5.6	
SEER / SCOP <sup>(2)</sup>	W/W	6.1	4.1	5.6	3.8	
Energy efficiency class		A++	A+	A+	A	
Annual energy consumption	kWh	298	2015	325	2063	
Tbiv	°C	N/A	-7	N/A	-7	
Tol	°C	N/A	-15	N/A	-15	
Power supply	V/Ph/Hz	220-240V/Single/50Hz				
Circuit breaker rating	A	25				
Rated power input (Maximum power input)	kW	3.2				
Rated current (Maximum current)	A	14.5				
OUTDOOR	Refrigerant control		Capillary+EXV			
	Compressor type. model		Twin Rotary DC Inverter			
	Fan type & quantity		Axial x 1			
	Fan speeds	H/L	RPM	750		
	Air flow	H/L	m <sup>3</sup> /hr	2500		
	Sound power level <sup>(4)</sup>	H/L	dB(A)	65		
	Sound pressure level <sup>(5)</sup>	H/L	dB(A)	55		
	Dimensions	WxHxD	mm	845x700x320		
	Weight		kg	48		
	Package dimensions	LxWxH	mm	965x395x755		
	Packaged weight		kg	52		
	Stacking height		units	2 levels		
	Refrigerant type			R410A		
	Refrigerant charge (standard connecting tubing length)		kg(10m)	1.9		
	Additional charge per 1 meter		gr / 1m	10m<L<20m 15g/m		
	Connections between units	Liquid line		In.(mm)	2x1/4"(Φ6.35)	
		Suction line		In.(mm)	2x3/8"(Φ9.52)	
		Max. length for all rooms		m	30	
Max. length for one indoor unit			m	20		
Max. height difference between indoor and outdoor unit		OU higher than IU		m	10	
		OU lower than IU		m	15	
Max. height difference between indoor units		m	10			
Operation control type			Remote control			

Model Outdoor Unit			AWAU-YCZ327-H11			
Installation Method of Pipe			3 x AWSI-HND009-N11	3 x AWSI-HKD009-N11		
Installation Method of Pipe			Flared		Flared	
Characteristics	Units	Cooling	Heating	Cooling	Heating	
			Average		Average	
Capacity <sup>(1)</sup>	kW	7.8	8.5	7.8	8.5	
Pdesign	kW	7.8	8	7.8	8	
SEER / SCOP <sup>(2)</sup>	W/W	6.6	3.9	6.1	3.8	
Energy efficiency class		A++	A	A++	A	
Annual energy consumption	kWh	414	2872	448	2947	
Tbiv	°C	N/A	-7	N/A	-7	
Tol	°C	N/A	-15	N/A	-15	
Power supply	V/Ph/Hz	220-240V/Single/50Hz				
Circuit breaker rating	A	25				
Rated power input (Maximum power input)	kW	3.6				
Rated current (Maximum current)	A	16.5				
OUTDOOR	Refrigerant control		Capillary+EXV			
	Compressor type. model		Twin Rotary DC Inverter			
	Fan type & quantity		Axial x 1			
	Fan speeds	H/L	RPM	800		
	Air flow	H/L	m3/hr	3500		
	Sound power level <sup>(4)</sup>	H/L	dB(A)	68		
	Sound pressure level <sup>(5)</sup>	H/L	dB(A)	58		
	Dimensions	WxHxD	mm	900x860x315		
	Weight		kg	62		
	Package dimensions	LxWxH	mm	1043x395x915		
	Packaged weight		kg	67		
	Stacking height		units	2 levels		
	Refrigerant type			R410A		
	Refrigerant charge (standard connecting tubing length)		kg(10m)	2.4		
	Additional charge per 1 meter		gr / 1m	15m<L<25m 15g/m		
	Connections between units	Liquid line		ln.(mm)	3x1/4"(Φ6.35)	
		Suction line		ln.(mm)	3x3/8"(Φ9.52)	
Max. length for all rooms		m	45			
Max. length for one indoor unit		m	25			
Max. height difference between indoor and outdoor unit		OU higher than IU		m	10	
		OU lower than IU		m	15	
Max. height difference between indoor units		m	10			
Operation control type			Remote control			

Model Outdoor Unit		AWAU-YCZ430-H11				
Installation Method of Pipe		4 x AWSI-HND009-N11		4 x AWSI-HKD009-N11		
Installation Method of Pipe		Flared		Flared		
Characteristics		Units	Cooling	Heating Average	Cooling	Heating Average
<b>Capacity <sup>(1)</sup></b>		<b>kW</b>	<b>8.5</b>	<b>9</b>	<b>8.5</b>	<b>9</b>
Pdesign		kW	8.5	8.2	8.5	8.2
SEER / SCOP <sup>(2)</sup>		W/W	6.6	3.9	5.8	3.8
Energy efficiency class			A++	A	A+	A
Annual energy consumption		kWh	451	2944	513	3021
Tbiv		°C	N/A	-7	N/A	-7
Tol		°C	N/A	-15	N/A	-15
Power supply		V/Ph/Hz	220-240V/Single/50Hz			
Circuit breaker rating		A	25			
Rated power input (Maximum power input)		kW	3.7			
Rated current (Maximum current)		A	17			
OUTDOOR	Refrigerant control		Capillary+EXV			
	Compressor type. model		Twin Rotary DC Inverter			
	Fan type & quantity		Axial x 1			
	Fan speeds		H/L	RPM	800	
	Air flow		H/L	m <sup>3</sup> /hr	3800	
	Sound power level <sup>(4)</sup>		H/L	dB(A)	70	
	Sound pressure level <sup>(5)</sup>		H/L	dB(A)	58	
	Dimensions		WxHxD	mm	900x860x315	
	Weight			kg	65	
	Package dimensions		LxWxH	mm	1043x395x915	
	Packaged weight			kg	69	
	Stacking height			units	2 levels	
	Refrigerant type				R410A	
	Refrigerant charge (standard connecting tubing length)		kg(10m)		2.4	
	Additional charge per 1 meter		gr / 1m		20m<L<30m 15g/m	
	Connections between units	Liquid line		ln.(mm)	4x1/4"(Φ6.35)	
		Suction line		ln.(mm)	4x3/8"(Φ9.52)	
Max. length for all rooms			m	60		
Max. length for one indoor unit			m	30		
Max. height difference between indoor and outdoor unit		OU higher than IU		m	10	
		OU lower than IU		m	15	
Max. height difference between indoor units			m	10		
Operation control type				Remote control		



Model Outdoor Unit		AWAU-YCZ536-H11				
Installation Method of Pipe		5 x AWSI-HND009-N11		5 x AWSI-HKD009-N11		
Installation Method of Pipe		Flared		Flared		
Characteristics	Units	Cooling	Heating	Cooling	Heating	
			Average		Average	
<b>Capacity <sup>(1)</sup></b>	<b>kW</b>	<b>10.5</b>	<b>11.5</b>	<b>10.5</b>	<b>11.5</b>	
Pdesign	kW	10.5	10.5	10.5	10.5	
SEER / SCOP <sup>(2)</sup>	W/W	5.6	3.8	5.1	3.8	
Energy efficiency class		A+	A	A	A	
Annual energy consumption	kWh	656	3868	721	3868	
Tbiv	°C	N/A	-7	N/A	-7	
Tol	°C	N/A	-15	N/A	-15	
Power supply	V/Ph/Hz	220-240V/Single/50Hz				
Circuit breaker rating	A	32				
Rated power input (Maximum power input)	kW	4.9				
Rated current (Maximum current)	A	22				
OUTDOOR	Refrigerant control		Capillary +EXV			
	Compressor type. model		Twin Rotary DC Inverter			
	Fan type & quantity		Axial x 1			
	Fan speeds	H/L	RPM	850		
	Air flow	H/L	m3/hr	5500		
	Sound power level <sup>(4)</sup>	H/L	dB(A)	70		
	Sound pressure level <sup>(5)</sup>	H/L	dB(A)	60		
	Dimensions	WxHxD	mm	990x345x965		
	Weight		kg	80		
	Package dimensions	LxWxH	mm	1120x435x1100		
	Packaged weight		kg	91		
	Stacking height		units	2 levels		
	Refrigerant type			R410A		
	Refrigerant charge (standard connecting tubing length)	kg(10m)		3		
	Additional charge per 1 meter	gr / 1m		25m<L<30m 15g/m		
	Connections between units	Liquid line		In.(mm)	5x1/4"(Φ6.35)	
		Suction line		In.(mm)	5x3/8"(Φ9.52)	
		Max. length for all rooms		m	75	
		Max. length for one indoor unit		m	30	
		Max. height difference between indoor and outdoor unit	OU higher than IU		m	10
OU lower than IU			m	15		
Max. height difference between indoor units		m	10			
Operation control type			Remote control			

Model Indoor Unit				AWSI-HND009-N11		AWSI-HND012-N11		
Installation Method of Pipe				Flared		Flared		
Characteristics			Units	Cooling	Heating	Cooling	Heating	
Capacity (4)			kW	2.7	2.8	3.5	3.7	
Power supply			V	220-240		220-240		
			Ph	1		1		
			Hz	50		50		
INDOOR	Fan type & quantity				Crossflow x 1		Crossflow x 1	
	Fan speeds	Cooling	SH/H/M/L	RPM	1150 / 1000 / 750		1170 / 1000 / 800	
		Heating	SH/H/M/L	RPM	1150 / 1000 / 750		1170 / 1000 / 800	
	Air flow (1)		SH/H/M/L	m3/hr	530/460/350		630/490/380	
	External static pressure		Min	Pa	0		0	
	Sound power level (2)		SH/H/M/L	dB(A)	53		57	
	Sound pressure level(3)		SH/H/M/L	dB(A)	40/37/28		41/37/28	
	Moisture removal			l/hr	1.0		1.3	
	Condensate drain tube I.D			mm	ODΦ17.5		ODΦ17.5	
	Dimensions		WxHxD	mm	750x280x198		835x280x198	
	Net Weight			kg	8		9	
	Package dimensions		LxWxH	mm	830x270x355		910x270x355	
Packaged weight			kg	10.1		14		
Operation control type					Remote control		Remote control	

Model Indoor Unit				AWSI-HND018-N11		AWSI-HKD009-N11		
Installation Method of Pipe				Flared		Flared		
Characteristics			Units	Cooling	Heating	Cooling	Heating	
Capacity (4)			kW	5	5.6	2.7	2.8	
Power supply			V	220-240		220-240		
			Ph	1		1		
			Hz	50		50		
INDOOR	Fan type & quantity				Crossflow x 1		Crossflow x 1	
	Fan speeds	Cooling	SH/H/M/L	RPM	1150 / 900 / 750		1150 / 1000 / 800	
		Heating	SH/H/M/L	RPM	1150 / 900 / 750		1150 / 1000 / 800	
	Air flow (1)		SH/H/M/L	m3/hr	1000/780/650		620/540/440	
	External static pressure		Min	Pa	0		0	
	Sound power level (2)		SH/H/M/L	dB(A)	58		58	
	Sound pressure level(3)		SH/H/M/L	dB(A)	47/40/34		42/38/30	
	Moisture removal			l/hr	1.7		1,0	
	Condensate drain tube I.D			mm	ODΦ17.5		ODΦ17.5	
	Dimensions		WxHxD	mm	990x315x218		800x275x188	
	Net Weight			kg	12.5		6.5	
	Package dimensions		LxWxH	mm	1065x300x400		865x265x350	
Packaged weight			kg	15.4		9.5		
Operation control type					Remote control		Remote control	

Model Indoor Unit				AWSI-HKD012-N11		AWSI-HKD018-N11		
Installation Method of Pipe				Flared		Flared		
Characteristics			Units	Cooling	Heating	Cooling	Heating	
Capacity (4)			kW	3.2	3.5	5	5.1	
Power supply			V	220-240		220-240		
			Ph	1		1		
			Hz	50		50		
INDOOR	Fan type & quantity				Crossflow x 1		Crossflow x 1	
	Fan speeds	Cooling	SH/H/M/L	RPM	1200 / 1050 / 800		1100 / 800 / 700	
		Heating	SH/H/M/L	RPM	1200 / 1050 / 800		1100 / 800 / 700	
	Air flow (1)		SH/H/M/L	m3/hr	630/550/430		730/480/400	
	External static pressure		Min	Pa	0		0	
	Sound power level (2)		SH/H/M/L	dB(A)	58		58	
	Sound pressure level(3)		SH/H/M/L	dB(A)	43/39/31		43/40/33	
	Moisture removal			l/hr	1,1		1,7	
	Condensate drain tube I.D			mm	ODΦ17.5		ODΦ17.5	
	Dimensions		WxHxD	mm	800x275x188		940x275x205	
	Net Weight			kg	7.5		9.5	
	Package dimensions		LxWxH	mm	865x265x350		1015x265x350	
Packaged weight			kg	9.5		12.5		
Operation control type					Remote control		Remote control	

Model Indoor Unit				AWSI-XAD012-N11		AWSI-DCD012-N11		
Installation Method of Pipe				Flared		Flared		
Characteristics			Units	Cooling	Heating	Cooling	Heating	
Capacity (4)			kW	3.5	3.6	3.5	3.8	
Power supply			V	220-240		220-240		
			Ph	1		1		
			Hz	50		50		
INDOOR	Fan type & quantity				Centrifugal fan x1		Centrifugal fan x2	
	Fan speeds	Cooling	SH/H/M/L	RPM	810/780/680/530		1200/1070/1000	
		Heating	SH/H/M/L	RPM	810/780/680/530		1200/1070/1000	
	Air flow (1)		SH/H/M/L	m3/hr	700/640/560/440		560/440/410	
	External static pressure		Min	Pa	0		25(0~40)	
	Sound power level (2)		SH/H/M/L	dB(A)	58		58	
	Sound pressure level(3)		SH/H/M/L	dB(A)	44/40/36		41/39/36	
	Moisture removal			l/hr	1,5		1.5	
	Condensate drain tube I.D			mm	ODΦ16		ODΦ25	
	Dimensions		WxHxD	mm	700x600x210		700x210x635	
	Net Weight			kg	15		18	
	Package dimensions		LxWxH	mm	810x305x710		915x655x290	
Packaged weight			kg	20		22.8		
Operation control type					Remote control		Wired remote control	

Model Indoor Unit				AWSI-CBD012-N11		
Installation Method of Pipe				Flared		
Characteristics			Units	Cooling	Heating	
Capacity (4)			kW	3.5	3.5	
Power supply			V	220-240		
			Ph	1		
			Hz	50		
INDOOR	Fan type & quantity				Centrifugal fan x1	
	Fan speeds	Cooling	SH/H/M/L	RPM	830/720/660	
		Heating	SH/H/M/L	RPM	830/720/660	
	Air flow (1)		SH/H/M/L	m <sup>3</sup> /hr	800/710/560	
	External static pressure		Min	Pa	0	
	Sound power level (2)		SH/H/M/L	dB(A)	55	
	Sound pressure level(3)		SH/H/M/L	dB(A)	44/41/38	
	Moisture removal			l/hr	1.5	
	Condensate drain tube I.D			mm	ODΦ25	
	Dimensions		WxHxD	mm	570x260x570	
	Net Weight			kg	16	
	Package dimensions		LxWxH	mm	655x655x290	
	Packaged weight			kg	19	
	Frame dimensions		WxHxD	mm	647x50x647	
	Frame net weight			kg	2.5	
Frame package dimensions		LxWxH	mm	715x715x123		
Frame packaged weight			kg	4.5		
Operation control type				Remote control		

# Part 2

## Indoor Units

HKD Type .....	12
HND Type .....	22
Light Commercial.....	33

---

# HKD Type

<b>1. Function.....</b>	<b>13</b>
<b>2. Dimensions.....</b>	<b>14</b>
<b>3. Wiring Diagrams .....</b>	<b>15</b>
<b>4. Exploded View and Spare Part list.....</b>	<b>16</b>

### 1. Function

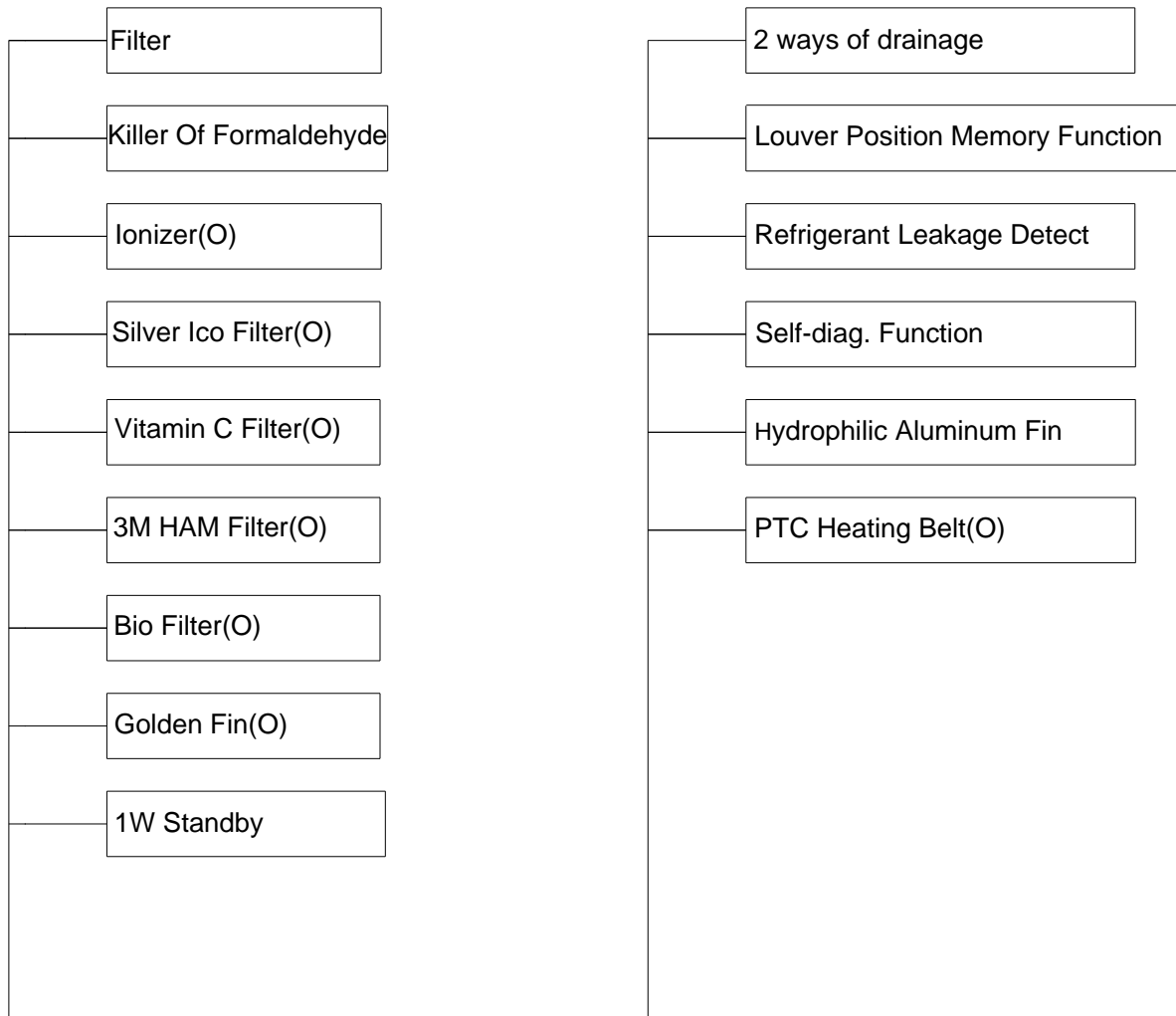

O: optional function

## 2. Dimensions

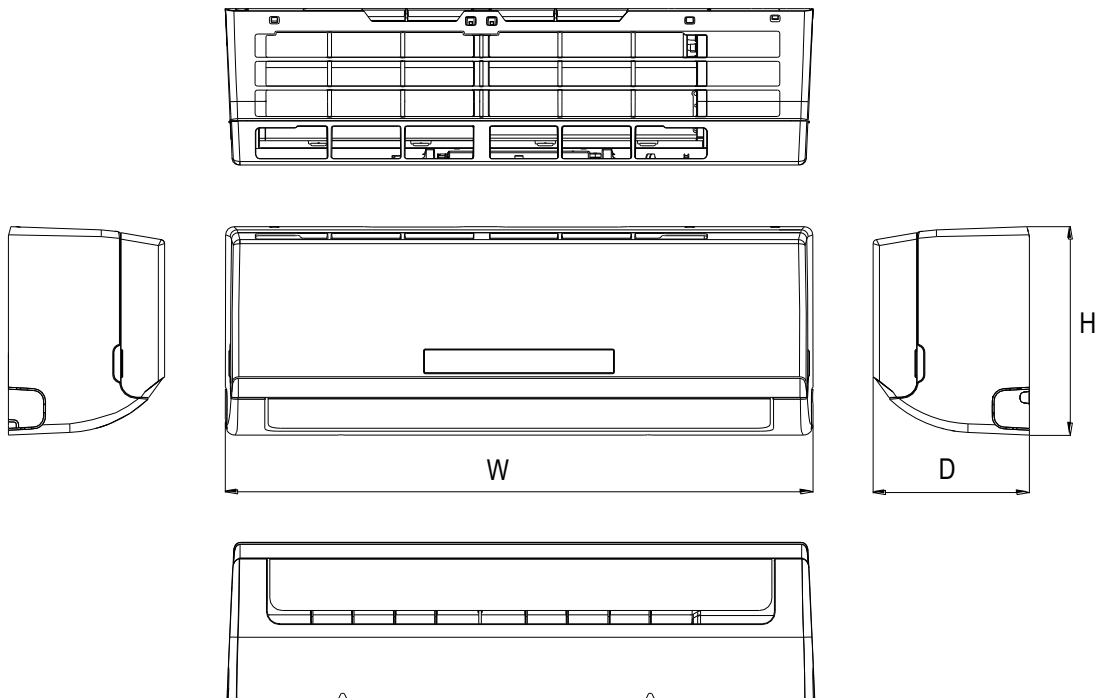

Model	W	D	H
AWSI-HKD009-N11	800	188	275
AWSI-HKD012-N11	800	188	275
AWSI-HKD018-N11	940	205	275

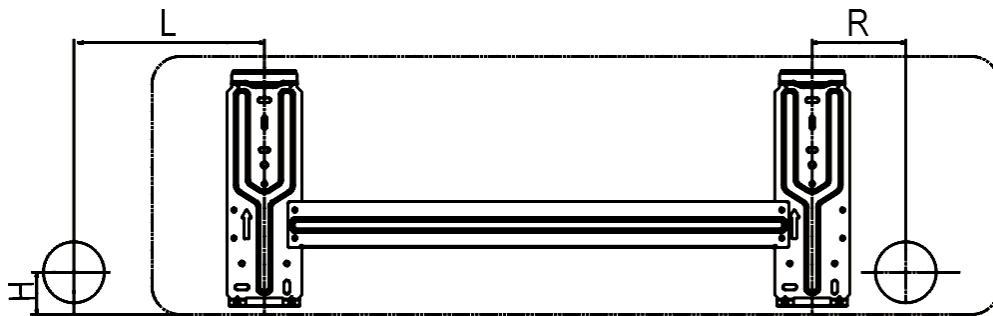

Model	L(mm)	R(mm)	H(mm)	Dimension of installation hole(mm)
AWSI-HKD009-N11	100	95	45	∅ 65
AWSI-HKD012-N11				
AWSI-HKD018-N11	110	100	45	



### 3. Wiring Diagrams

AWSI-HKD009-N11, AWSI-HKD012-N11, AWSI-HKD018-N11

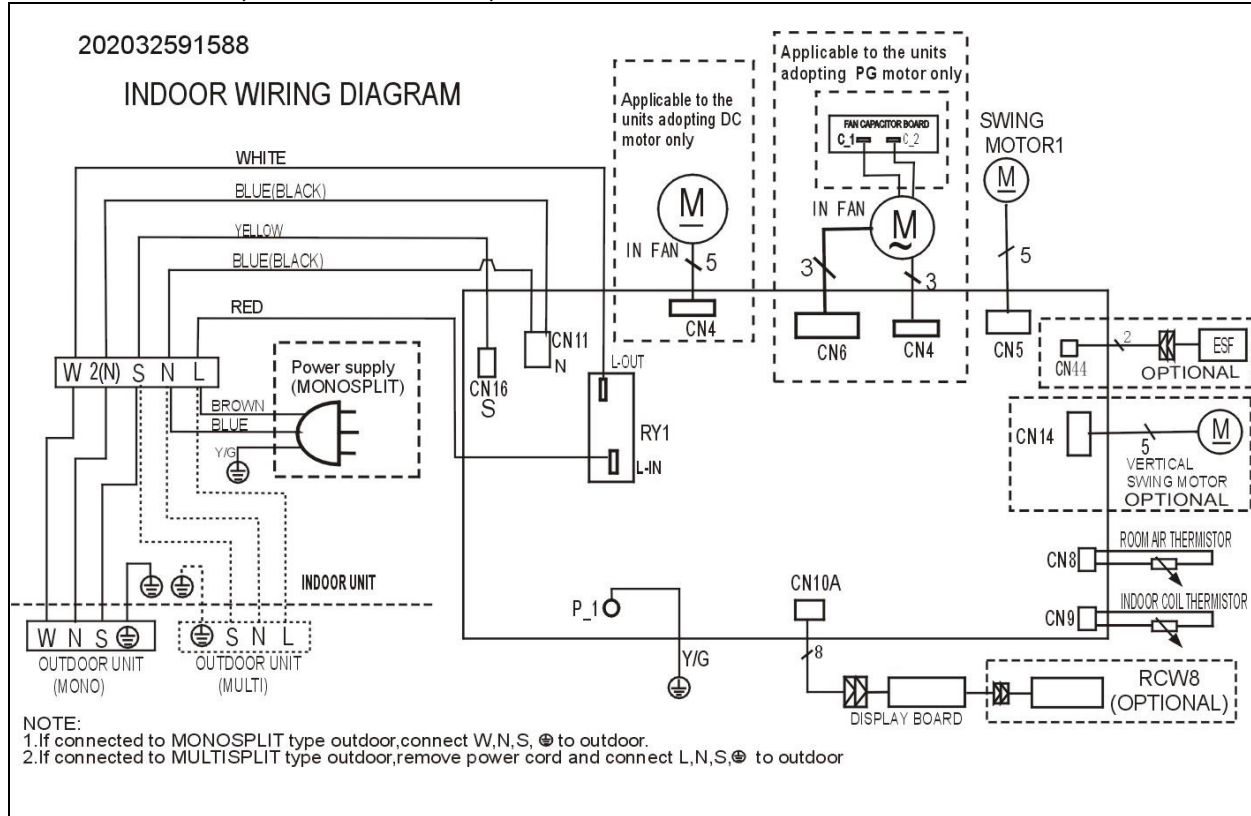

### 4. Exploded View and Spare Part list

Exploded View of indoor unit: AWSI-HKD009-N11

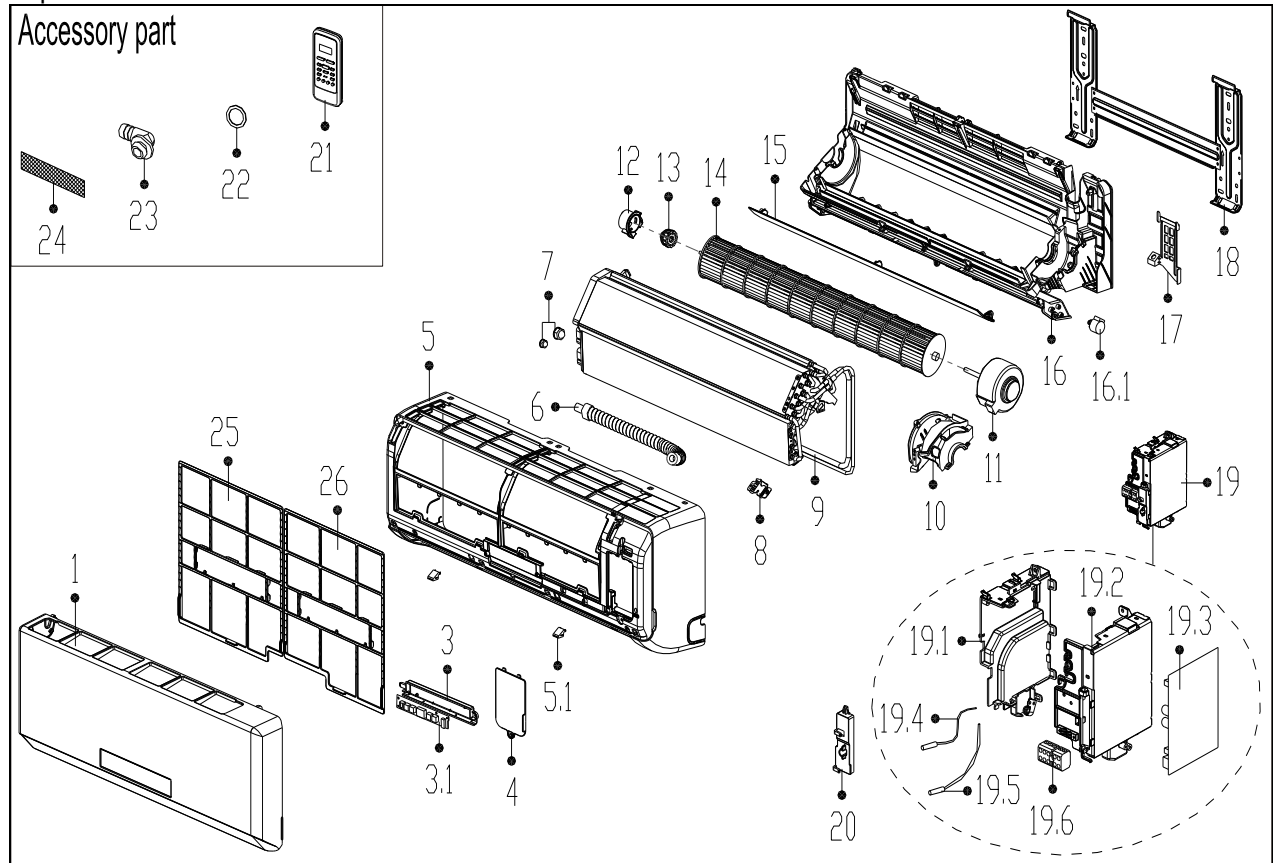

## Spare part list of indoor unit: AWSI-HKD009-N11

No.	Part Name	Qty	BOM Code	No.	Part Name	Qty	BOM Code
1	Panel assembly	1	2011325A5387	16.1	Louver motor	1	202400200031
3	Display box assembly	1	2033325A2367	17	Pipe clamp board	1	201119900949
3.1	Display board assembly	1	2013330A0831	18	Installation plate	1	201232590037
4	Cover of electrical equipment	1	201119901024	19	Electronic control box assembly	1	203332391198
5	Panel assembly frame	1	201132591041	19.1	Electronic control box I	1	201132490125
5.1	Screw cap	2	201119900950	19.2	Electronic control box II	1	201132490150
6	Drain hose	1	201101020038	19.3	Indoor main control board assembly	1	201332391780
7	Pipe Nut	1	201600320001	19.4	Ambient temperature sensor assembly	1	202433190000
7	Pipe Nut	1	201600320000	19.5	Pipe temperature sensor assembly	1	202301300426
8	Fix clamp of temperature sensor	1	201102000305	19.6	Wire joint	1	202301450119
9	Evaporator assembly	1	201532390220	20	Cover of electronic control box	1	201132490126
10	Fan motor cover	1	201132490127	21	Remote Controller	1	203355091552
11	Asynchronous motor	1	202400400213	22	Seal ring	1	202720090001
12	Bearing holder	1	201119900952	23	Drain joint	1	201101020011
13	Bearing base	1	202719900606	24	Anti-bacterial filter	1	201131410703
14	Cross flow fan	1	201100200306	25	Air filter(left)	1	201132591042
15	Horizontal louver	1	201132591044	26	Air filter(right)	1	201132591040
16	Chassis assembly	1	201132591057		Nano photocatalysis filter	1	201130100273

Exploded View of indoor unit: AWSI-HKD012-N11

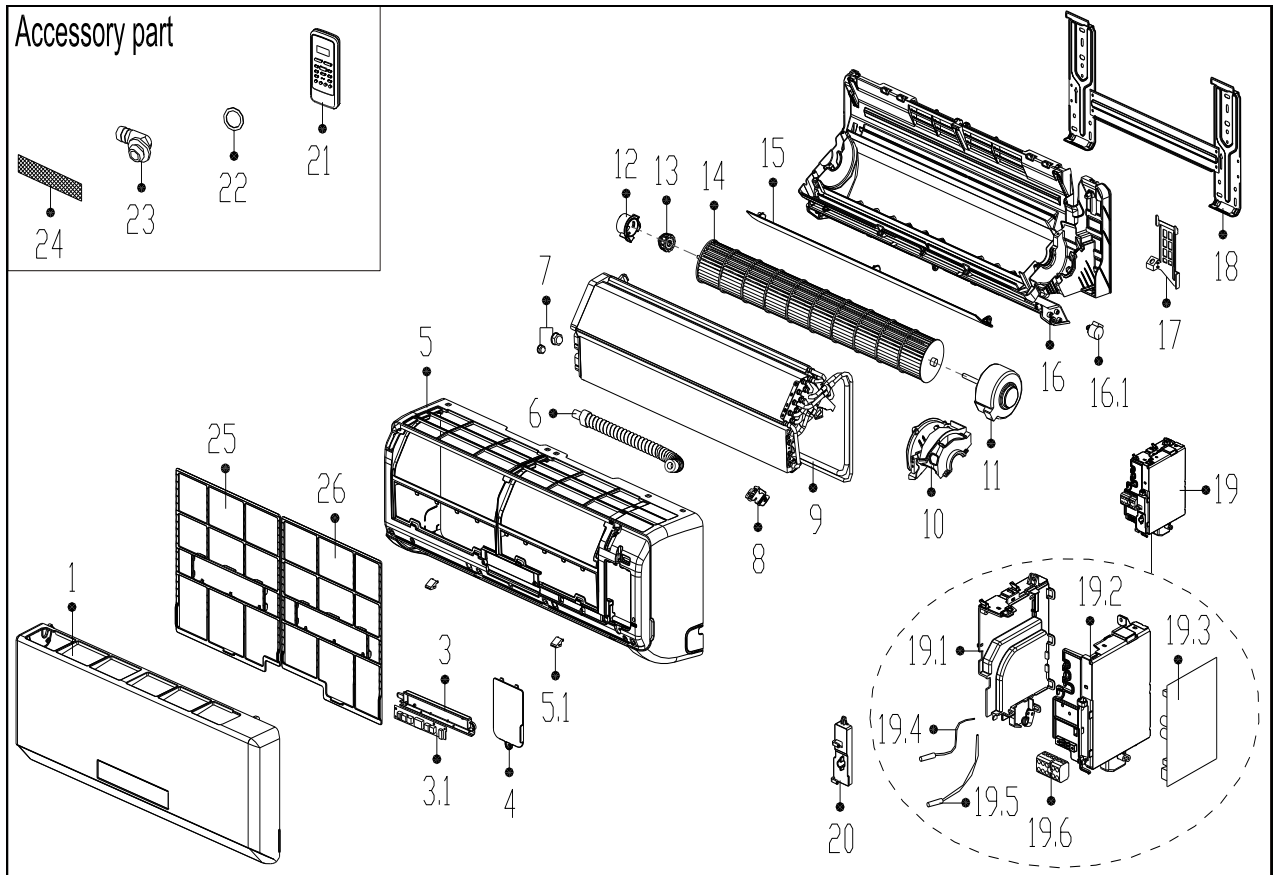

## Spare part list of indoor unit: AWSI-HKD012-N11

No.	Part Name	Qty	BOM Code	No.	Part Name	Qty	BOM Code
1	Panel assembly	1	2011325A5387	16.1	Louver motor	1	202400200031
3	Display box assembly	1	2033325A2367	17	Pipe clamp board	1	201119900949
3.1	Display board assembly	1	2013330A0831	18	Installation plate	1	201232590037
4	Cover of electrical equipment	1	201119901024	19	Electronic control box assembly	1	203332490311
5	Panel assembly frame	1	201132591041	19.1	Electronic control box I	1	201132490125
5.1	Screw cap	2	201119900950	19.2	Electronic control box II	1	201132490150
6	Drain hose	1	201101020038	19.3	Indoor main control board assembly	1	201332490360
7	Pipe Nut	1	201600320001	19.4	Ambient temperature sensor assembly	1	202433190000
7	Pipe Nut	1	201600320000	19.5	Pipe temperature sensor assembly	1	202301300426
8	Fix clamp of temperature sensor	1	201102000305	19.6	Wire joint	1	202301450119
9	Evaporator assembly	1	201532390220	20	Cover of electronic control box	1	201132490126
10	Fan motor cover	1	201132490127	21	Remote Controller	1	203355091552
11	Brushless DC Motor	1	202400370025	22	Seal ring	1	202720090001
12	Bearing holder	1	201119900952	23	Drain joint	1	201101020011
13	Bearing base	1	202719900606	24	Anti-bacterial filter	1	201131410703
14	Cross flow fan	1	201100200306	25	Air filter(left)	1	201132591042
15	Horizontal louver	1	201132591044	26	Air filter(right)	1	201132591040
16	Chassis assembly	1	201132591057		Nano photocatalysis filter	1	201130100273

Exploded View of indoor unit: AWSI-HKD018-N11

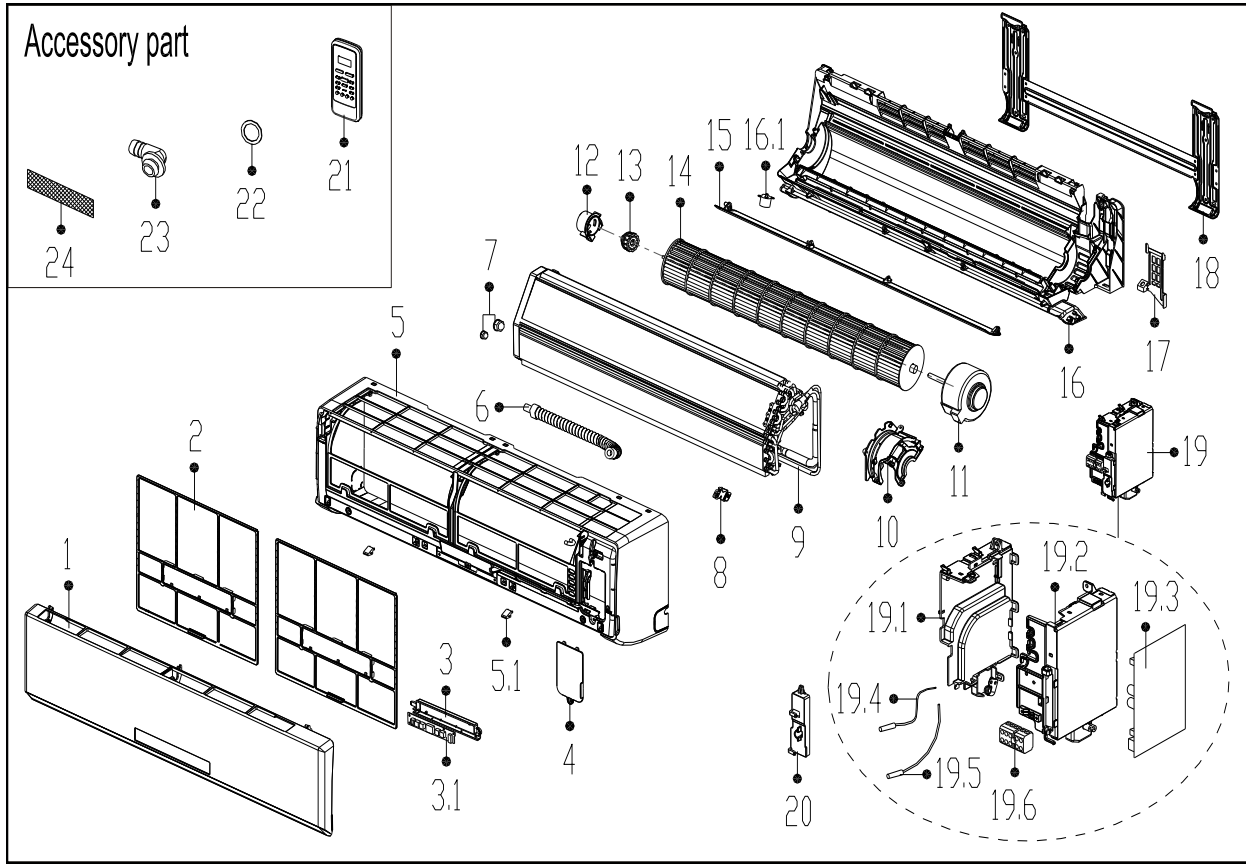

## Spare part list of indoor unit: AWSI-HKD018-N11

No.	Part Name	Qty	BOM Code	No.	Part Name	Qty	BOM Code
1	Panel assembly	1	2011327A4068	16	Chassis assembly	1	201132790680
2	Air filter	2	201132790664	16.1	Louver motor	1	202400200031
3	Display box assembly	1	2033325A2367	17	Pipe clamp board	1	201119900949
3.1	Display board assembly	1	2013330A0831	18	Installation plate	1	201232790013
4	Cover of electrical equipment	1	201119901024	19	Electronic control box assembly	1	203332890706
5	Panel assembly frame	1	201132790667	19.1	Electronic control box I	1	201132490125
5.1	Screw cap	2	201119900950	19.2	Electronic control box II	1	201132490150
6	Drain hose	1	201101020038	19.3	Indoor main control board assembly	1	201332890811
7	Pipe Nut	1	201600320002	19.4	Ambient temperature sensor assembly	1	202433190000
7	Pipe Nut	1	201600320000	19.5	Pipe temperature sensor assembly	1	202301300426
8	Fix clamp of temperature sensor	1	201102000305	19.6	Wire joint	1	202301450119
9	Evaporator assembly	1	201532890160	20	Cover of electronic control box	1	201132490126
10	Fan motor cover	1	201132790663	21	Remote Controller	1	203355091552
11	Brushless DC Motor	1	202400300517	22	Seal ring	1	202720090001
12	Bearing holder	1	201119900952	23	Drain joint	1	201101020011
13	Bearing base	1	202719900606	24	Anti-bacterial filter	1	201131410703
14	Cross flow fan	1	201100200322		Nano photocatalysis filter	1	201130100273
15	Horizontal louver	1	201132790665				

---

# HND Type

<b>1. Function.....</b>	<b>23</b>
<b>2. Dimensions.....</b>	<b>24</b>
<b>3. Wiring Diagrams .....</b>	<b>26</b>
<b>4. Exploded View and Spare Part list.....</b>	<b>27</b>



### 1. Function



O: optional function

## 2. Dimensions

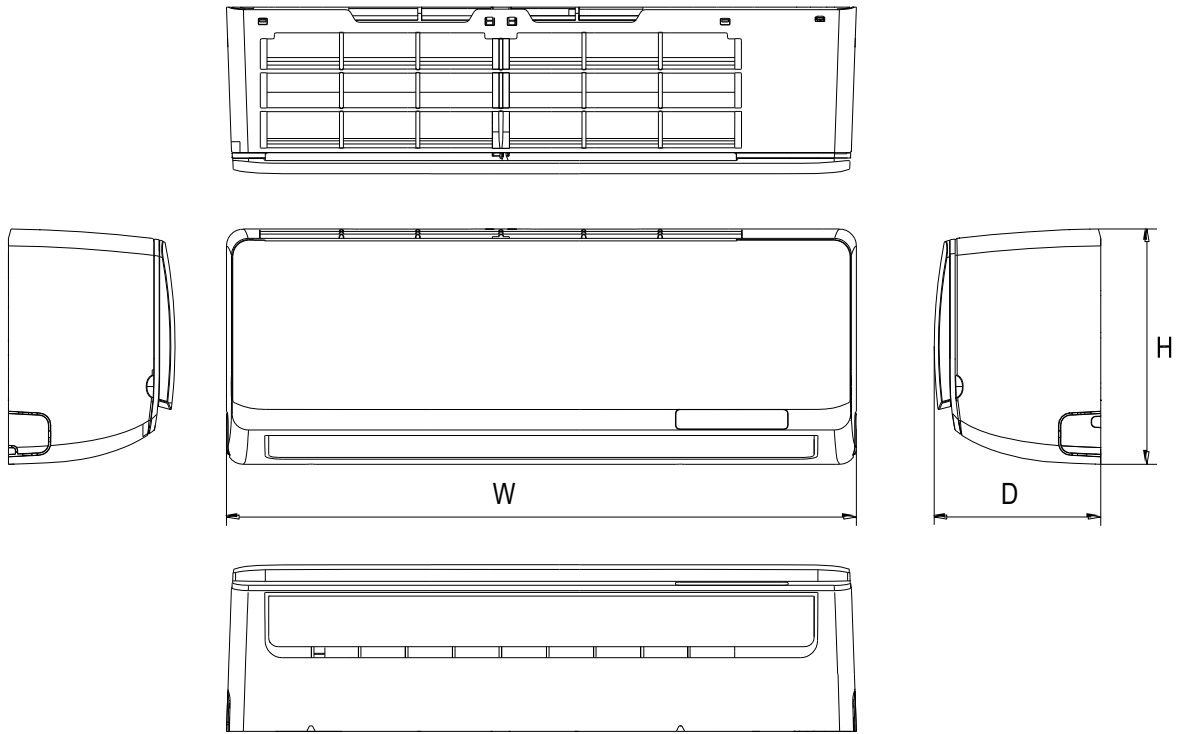

Model	W	D	H
AWSI-HND009-N11	750	198	280
AWSI-HND012-N11	835	198	280
AWSI-HND018-N11	990	218	315

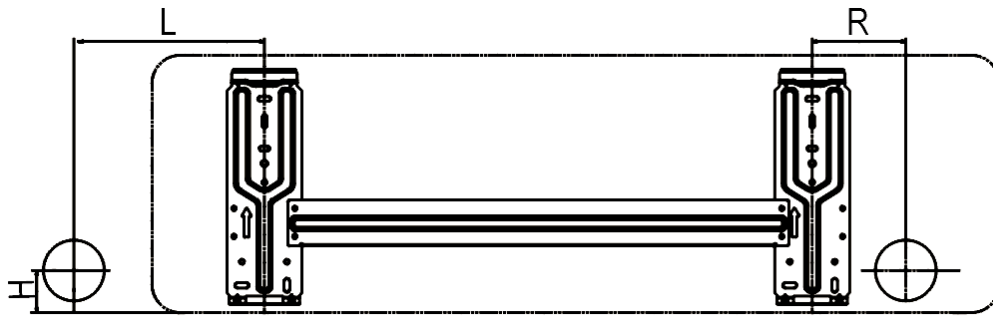

Model	L(mm)	R(mm)	H(mm)	Dimension of installation hole(mm)
AWSI-HND009-N11	180	110	45	∅ 65
AWSI-HND012-N11	140	110	45	

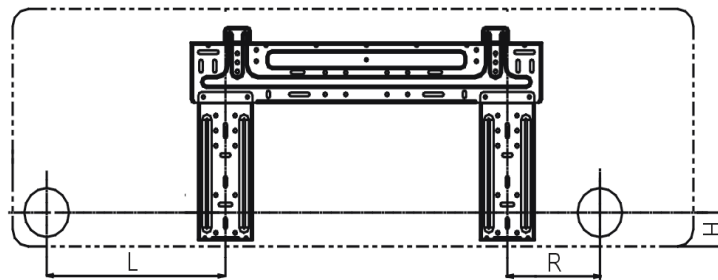

Model	L(mm)	R(mm)	H(mm)	Dimension of installation hole(mm)
AWSI-HND018-N11	260	135	45	∅ 65

### 3. Wiring Diagrams

**AWSI-HND009-N11, AWSI-HND012-N11**

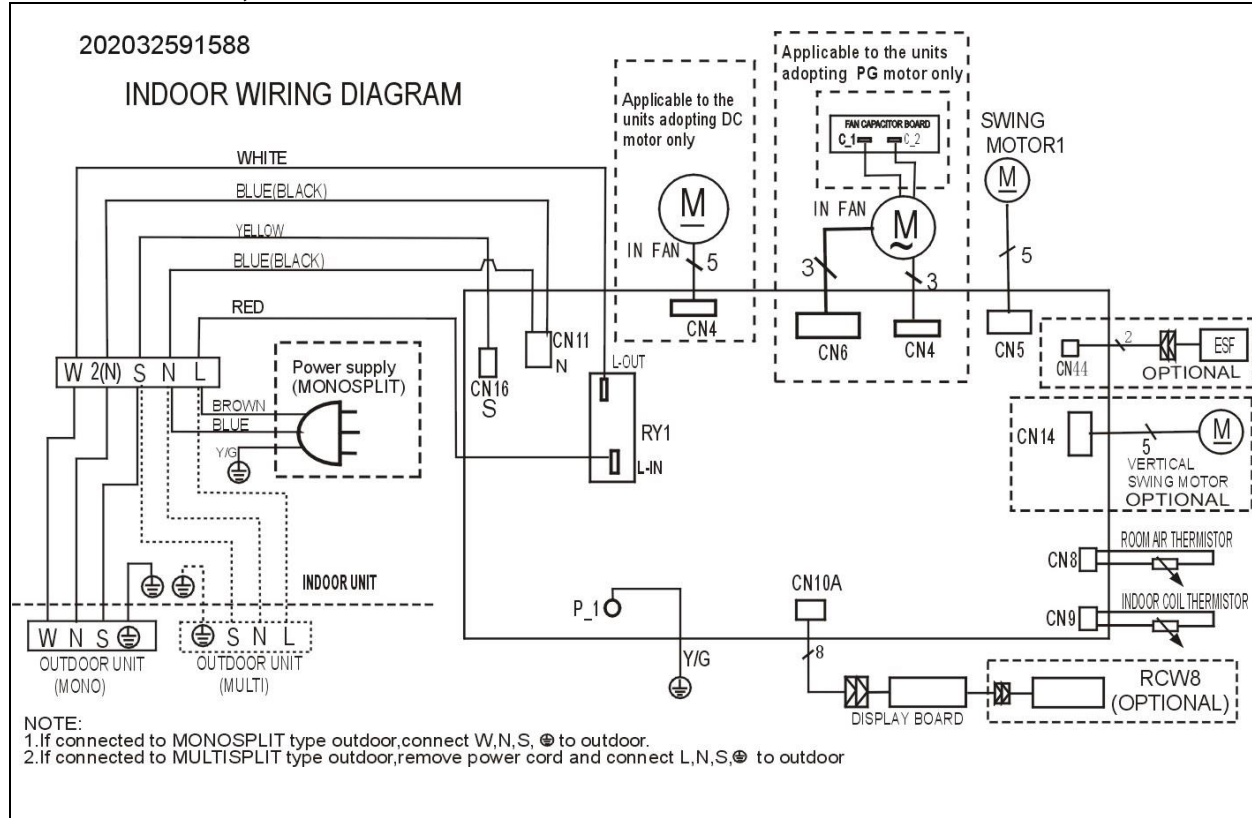

**AWSI-HND018-N11**

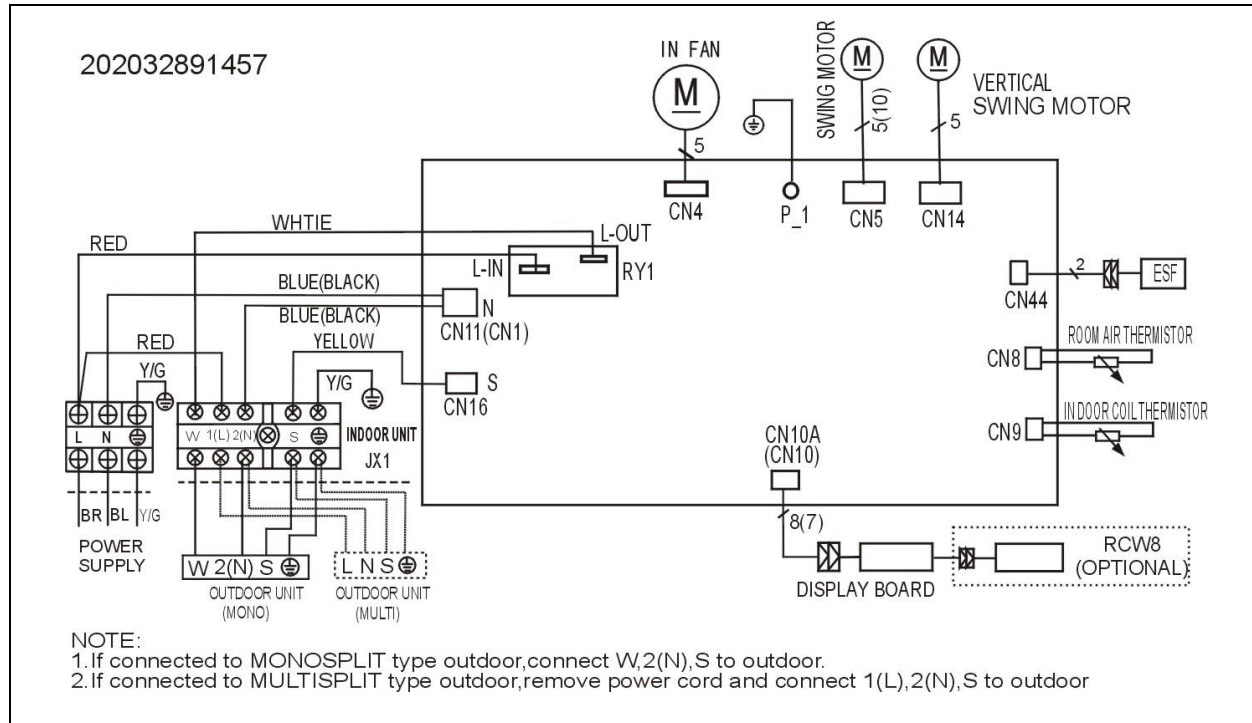

### 4. Exploded View and Spare Part list

Exploded View of indoor unit: AWSI-HND009-N11

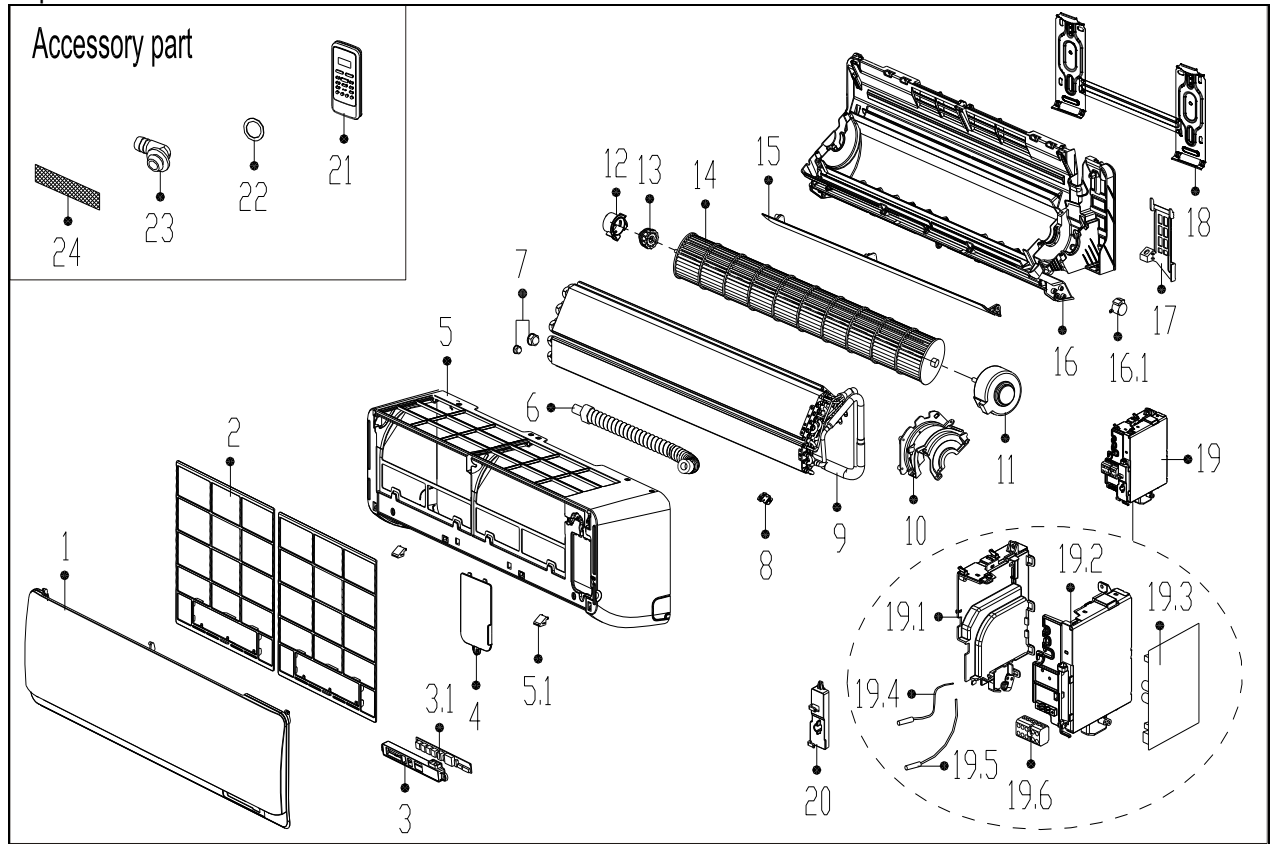

## Spare part list of indoor unit: AWSI-HND009-N11

No.	Part Name	Qty	BOM Code	No.	Part Name	Qty	BOM Code
1	Panel assembly	1	2011323A3829	16	Chassis assembly	1	201132391058
2	Air filter	2	201132391052	16.1	Louver motor	1	202400200031
3	Display box assembly	1	2033323A2544	17	Pipe clamp board	1	201119900949
3.1	Display board assembly	1	2013330A0830	18	Installation plate	1	201232590037
4	Cover of electrical equipment	1	201119901024	19	Electronic control box assembly	1	2033323A2552
5	Panel frame assembly	1	201132392602	19.1	Electronic control box I	1	201132490125
5.1	Screw cap	2	201119900950	19.2	Electronic control box II	1	201132490150
6	Drain hose	1	201101020038	19.3	Indoor main control board assembly	1	2013323A1827
7	Pipe nut	1	201600320001	19.4	Ambient temperature sensor assembly	1	202433190000
7	Pipe nut	1	201600320000	19.5	Pipe temperature sensor assembly	1	202301300426
8	Fix clamp of temperature sensor	1	201102000305	19.6	Wire joint	1	202301450119
9	Evaporator assembly	1	201532390212	20	Cover of electronic control box	1	201132490126
10	Fan motor cover	1	201132490127	21	Remote Controller	1	203355091552
11	Brushless DC Motor	1	202400370025	22	Seal ring	1	202720090001
12	Bearing holder	1	201119900952	23	Drain joint	1	201101020011
13	Bearing base	1	202719900606	24	Anti-bacterial filter	1	201131410703
14	Cross flow fan	1	201100200055		Nano photocatalysis filter	1	201130100273
15	Horizontal louver	1	201132391053		ESF	1	202319900113

Exploded View of indoor unit: AWSI-HND012-N11

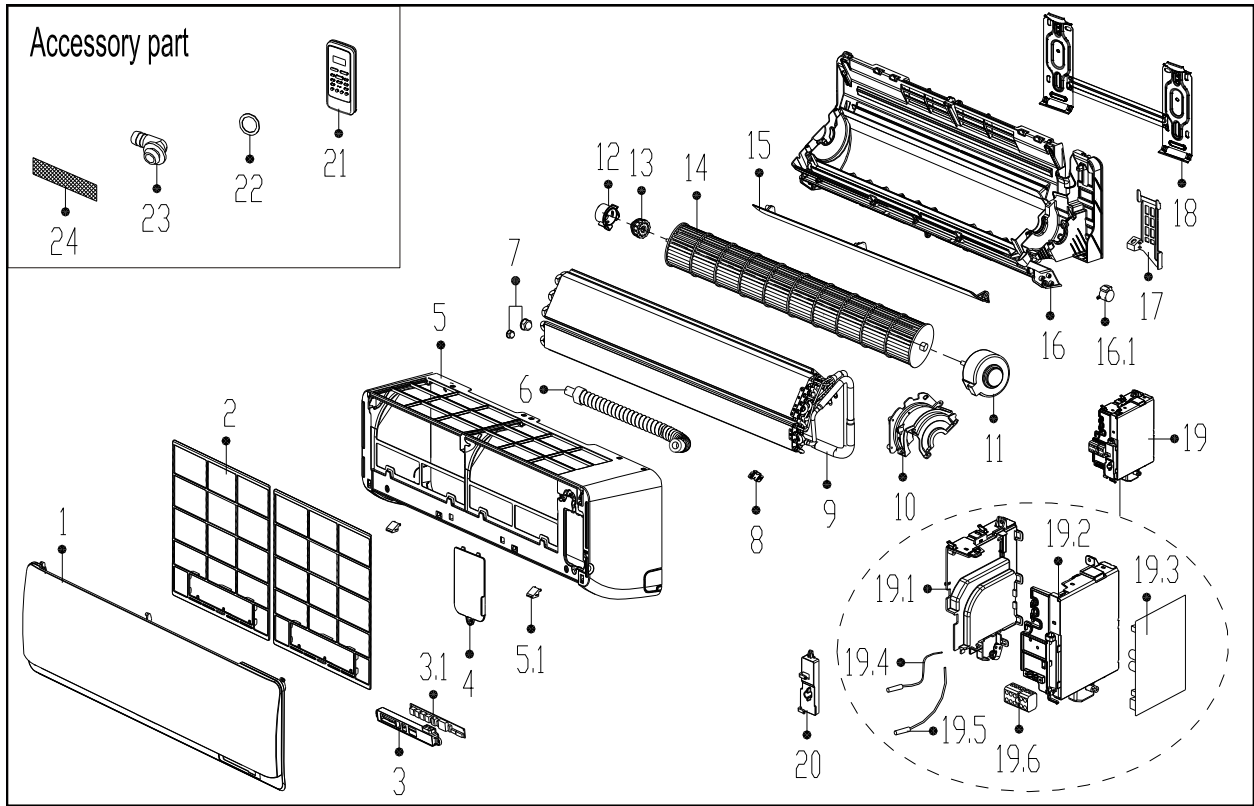

## Spare part list of indoor unit: AWSI-HND012-N11

No.	Part Name	Qty	BOM Code	No.	Part Name	Qty	BOM Code
1	Panel assembly	1	2011325A5384	16	Chassis assembly	1	201132590963
2	Air filter	2	201132590962	16.1	Louver motor	1	202400200031
3	Display box assembly	1	2033323A2544	17	Pipe clamp board	1	201119900949
3.1	Display board assembly	1	2013330A0830	18	Installation plate	1	201232590037
4	Cover of electrical equipment	1	201119901024	19	Electronic control box assembly	1	2033325A2373
5	Panel assembly frame	1	201132591059	19.1	Electronic control box I	1	201132490125
5.1	Screw cap	2	201119900950	19.2	Electronic control box II	1	201132490150
6	Drain hose	1	201101020038	19.3	Indoor main control board assembly	1	2013325A1249
7	Pipe nut	1	201600320001	19.4	Ambient temperature sensor assembly	1	202433190000
7	Pipe nut	1	201600320000	19.5	Pipe temperature sensor assembly	1	202301300426
8	Fix clamp of temperature sensor	1	201102000305	19.6	Wire joint	1	202301450119
9	Evaporator assembly	1	201532590453	20	Cover of electronic control box	1	201132490126
10	Fan motor cover	1	201132490127	21	Remote Controller	1	203355091552
11	Brushless DC Motor	1	202400370025	22	Seal ring	1	202720090001
12	Bearing holder	1	201119900952	23	Drain joint	1	201101020011
13	Bearing base	1	202719900606	24	Anti-bacterial filter	1	201131410703
14	Cross flow fan	1	201100200054		Nano photocatalysis filter	1	201130100273
15	Horizontal louver	1	201132590956		ESF	1	202319900113



Exploded View of indoor unit: AWSI-HND018-N11

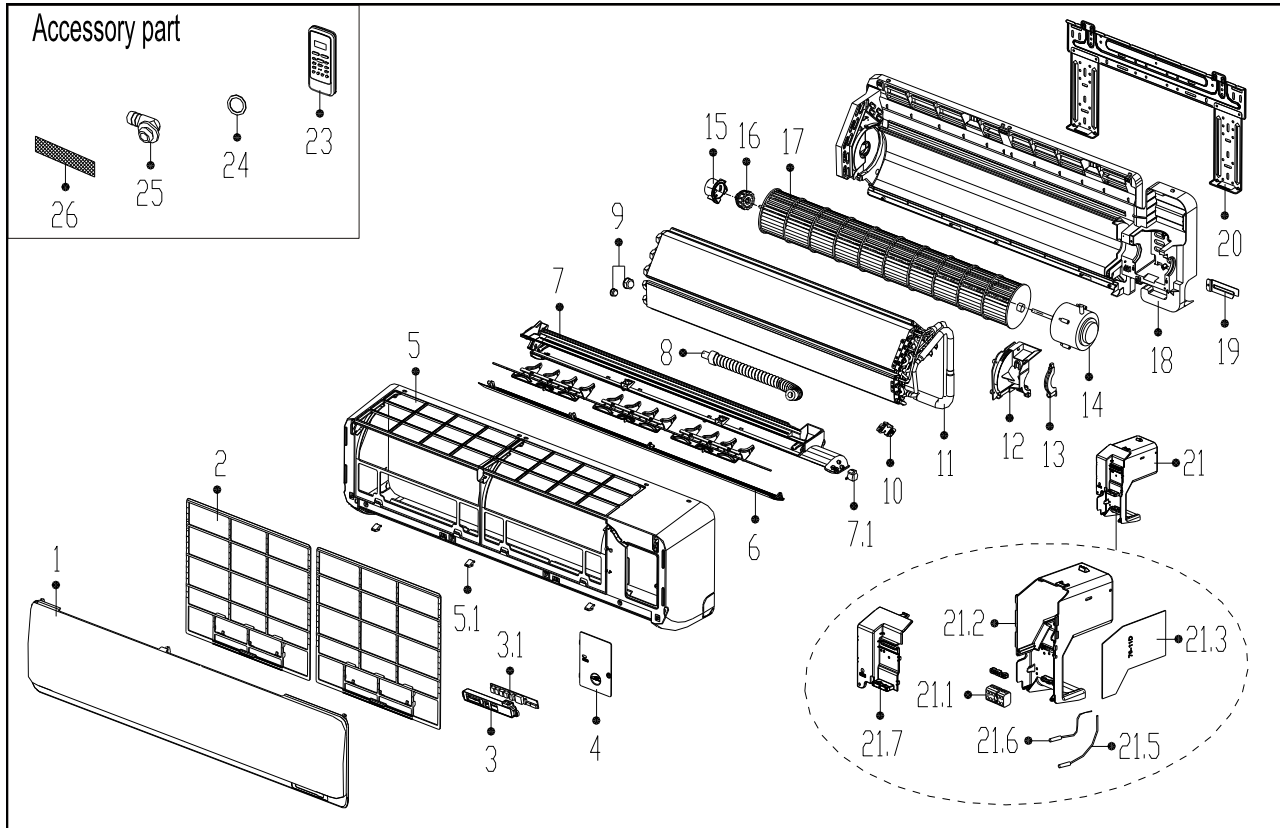

## Spare part list of indoor unit: AWSI-HND018-N11

No.	Part Name	Qty	BOM Code	No.	Part Name	Qty	BOM Code
1	Panel assembly	1	2011328A2355	16	Bearing base	1	202719900606
2	Air filter	2	201132890670	17	Cross flow fan	1	201100200056
3	Display box assembly	1	2033327A0877	18	Chassis assembly	1	201132890703
3.1	Display board assembly	1	2013330A0830	19	Pipe clamp board	1	201232800103
4	Cover of electrical equipment	1	201133091048	20	Installation plate	1	201232590038
5	Panel assembly frame	1	201132890673	21	Electronic control box assembly	1	2033328A0969
5.1	Screw cap	3	201119900950	21.1	Wire joint	1	202301450120
6	Horizontal louver	1	201132890671	21.1	Wire joint	1	202301450119
7	Air outlet assembly	1	2011328A1649	21.2	Electronic control box	1	201133090976
7.1	Louver motor	1	202400200120	21.3	Indoor main control board assembly	1	2013328A0727
8	Drain hose	1	201101020038	21.5	Ambient temperature sensor assembly	1	202432390005
9	Pipe nut	1	201600320000	21.6	Pipe temperature sensor assembly	1	202301300584
9	Pipe nut	1	201600320002	21.7	Cover of electronic control box	1	201133090981
10	Fix clamp of temperature sensor	1	201102000305	23	Remote Controller	1	203355091552
11	Evaporator assembly	1	201532890153	24	Seal ring	1	202720090001
12	Fan motor cover	1	201133090980	25	Drain joint	1	201101020011
13	Fixing board of fan motor	1	201133090167	26	Anti-bacterial filter	1	201131410703
14	Brushless DC Motor	1	202400300064		Nano photocatalysis filter	1	201130100273
15	Bearing holder	1	201119900952		ESF	1	202319900113

---

# Light Commercial

<b>1. Features.....</b>	<b>34</b>
<b>2. Dimensions.....</b>	<b>40</b>
<b>3. Service Space(unit:mm).....</b>	<b>42</b>
<b>4. Wiring Diagrams .....</b>	<b>44</b>
<b>5. Exploded View and Spare Part list.....</b>	<b>47</b>

## 1. Features

### 1.1 Four-way cassette type(compact)

#### (1) New panel

- 360°surrounding air outlet design, affords comfortable feeling

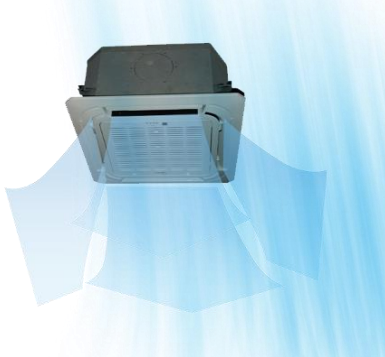

#### (2) Compact design

- The body size is 570×260×570mm, it's just smaller than the ceiling board, so it's very easy for installation and will not damage the decoration. The panel size is 647×50×647mm.
- The hooks are designed in the four corners of the body, which can save installation space.



#### (3) Electric control box built-in design

- The E-box is simply and safely built inside the indoor unit. It's convenient for installation and maintenance. Can check the control part easily, you only need to open the air return grille.



#### (4) Fresh air intake function:

- Fresh air fulfills air quality more healthy and comfortable.

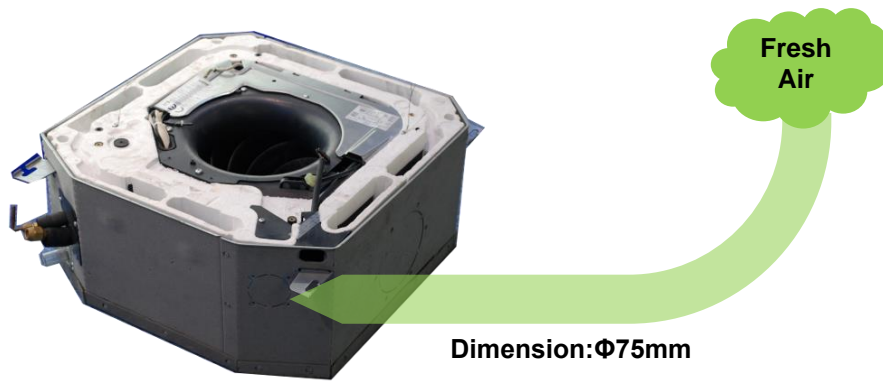

#### (5) Air passage function

- Reserves the space for air outlet from the side of indoor unit; It's availed to connect air duct from the two sides to the nearby small rooms.



## 1.2 A5 Duct

### (1) Installation accessories: (Optional)

- Front Board, Canvas Air Passage, Filter, Panel, for easy installation

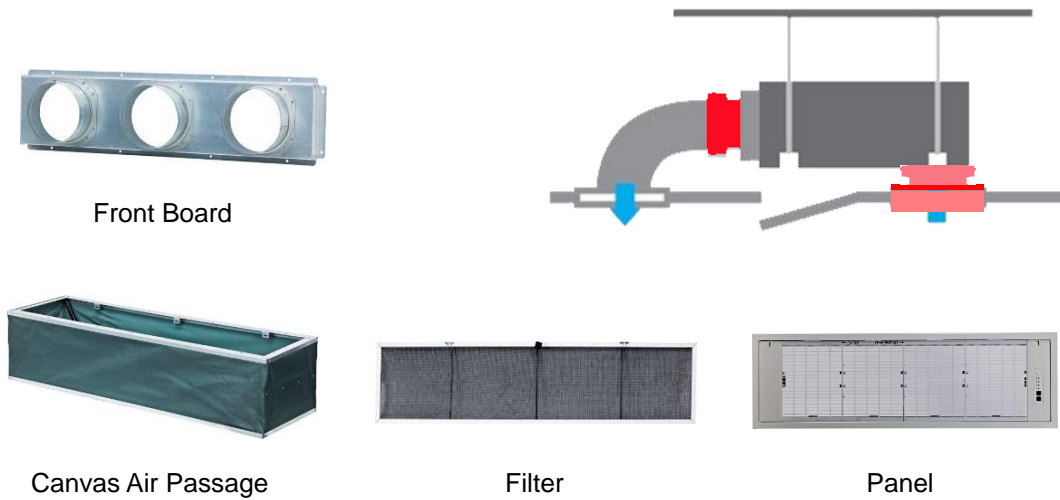

### (2) Easy Installation: Two air inlet styles (Bottom side or Rear side)

- Air inlet from rear is standard for all capacity; air inlet from bottom is optional.
- The size of air inlet frame from rear and bottom is same, it's very easy to move the cover from bottom to rear side, or from rear to the bottom, in order to matching the installation condition.

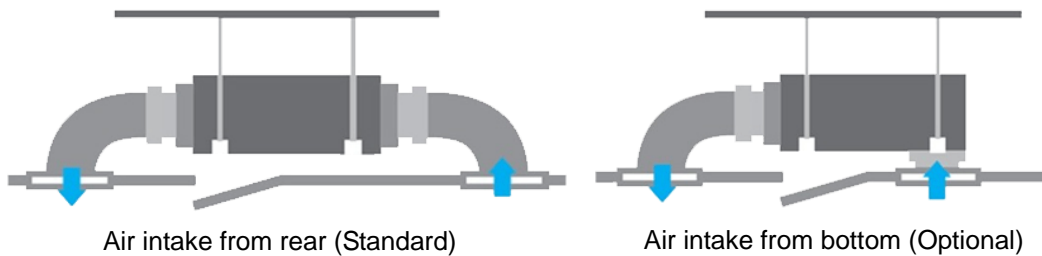

### (3) Fresh air intake function

- Install one duct from the reserved fresh-air intake to outdoor. Continually inhale the fresh air to improve the quality of the indoor air, fulfills air quality more healthy and comfortable.

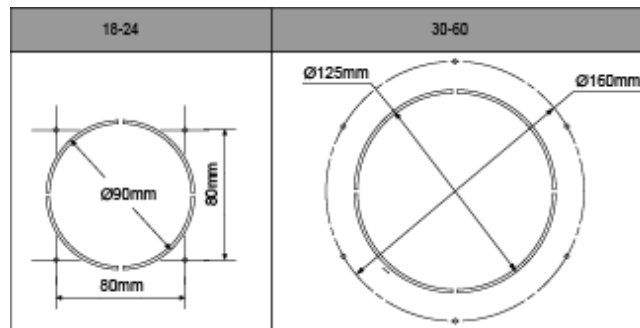

### (4) Easy maintenance

- Clean the filter (Optional, standard product without filter). It is easy to draw out the filter from the indoor unit for cleaning, even the filter is installed in rear side or bottom side.

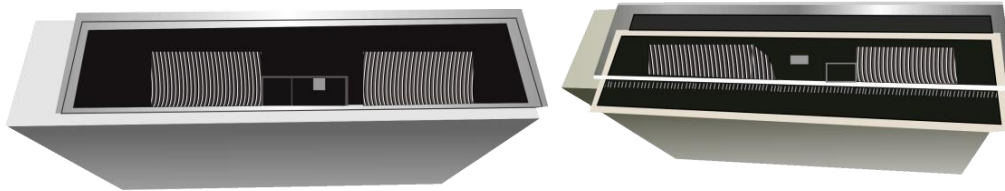

- Replace the motor or centrifugal fan  
Remove the ventilated panel firstly. Remove a half of blower housing and take out the motor with centrifugal fan. Directly remove two bolts, and then replace the motor or centrifugal fan easily.

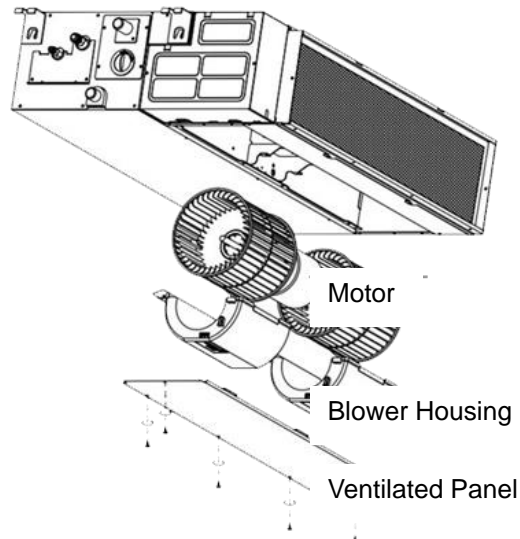

#### (5) Reserved remote on-off and central control ports

- Reserved remote on-off ports and central control ports, can connect the cable of an on-off controller or a central controller to realize remote on-off control function or group control function.

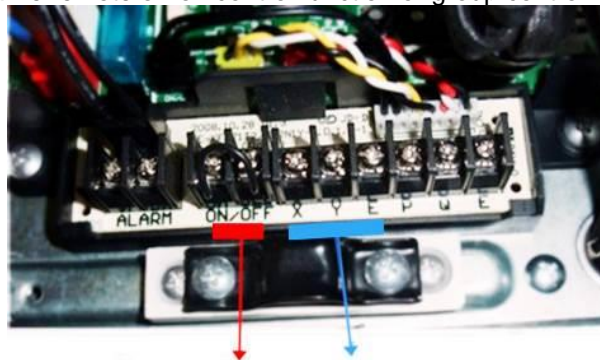

Remote on-off ports    Central control ports

#### (6) Built-in drain pump (Optional):

- Built-in drain pump can lift the water to 750mm upmost. It's convenient to install drainage piping under most space condition.

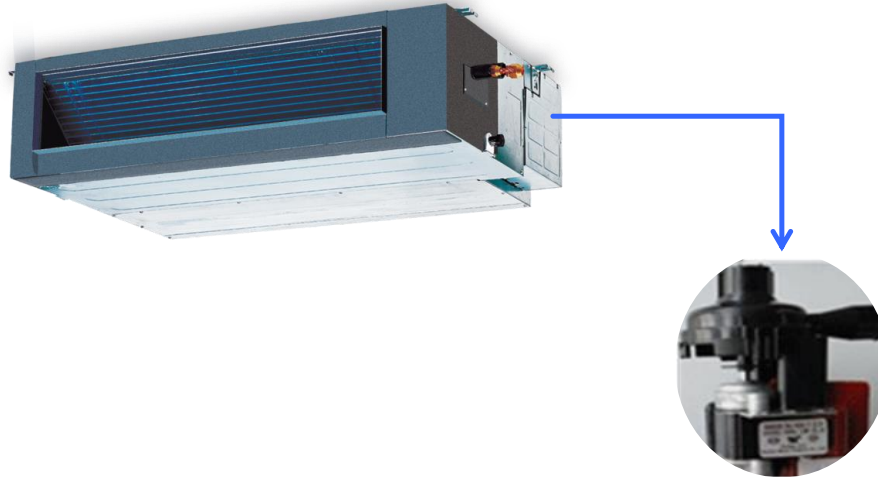
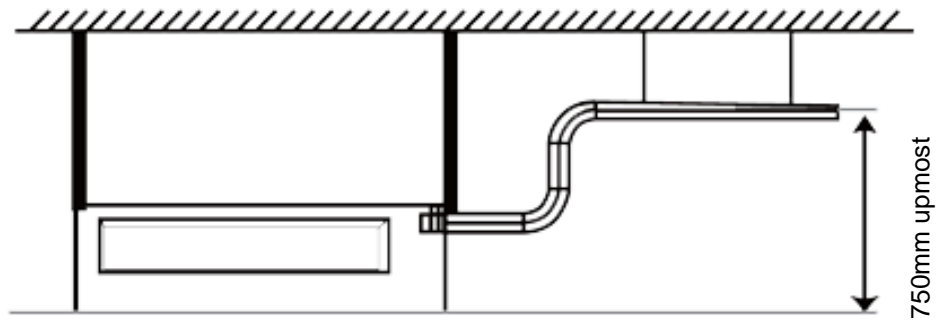

**(7) Built-in display board**

- The standard indoor unit can be controlled by wired controller.
- There is a display board with a receiver in the E-box. Move out the display, and fix it in other place, even in the distance of 10m. The unit will realized remoter control.
- The wired controller and the display board can display the error code or production code when the chips detect some failure.

Wired Controller (Standard)

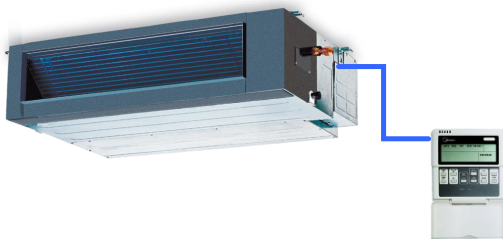

Remote Controller (Optional)

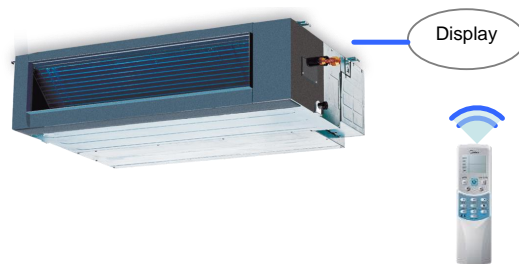



### 1.3 Console

**(1) Consumes up to 30% less energy than non-inverter units**

- DC inverter compressor
- indoor fan motor adopts DC motor

**(2) Achieves set temperature more quickly**

- air supplying from top and bottom or from top only
- air inlet from four directions



**(3) Compact unit body, space saving**

- this unit body is very thin and harmonious with room. It is beautiful, elegant and space saving.
- lightweight and compact.

**(4) Flexible installation.**

- can be used for floor standing or lower wall applications
- as a floor standing floor model, it can be semi or fully recessed without loss of capacity.

**(5) High efficiency filter**

- built in Formaldehyde nemesis filter
- active-carbon and biological anti-virus filter is optional.

**(6) Comfort**

- flexible air blow: vertical auto swing and wide angle louvers ensure that warm air reaches the furthest corners of the room and increase the air flow coverage
- Low noise operation, lowest to 23Db
- Low starting power and precise room temperature adjustment

**(7) Powerful mode can be selected for rapid cooling or heating.**

**(8) Easy cleaning grille and maintenance**

**(9) Indoor unit adopts DC motor, it has five level fan speed meet different requirements.**

## 2. Dimensions

### 2.1 Four-way cassette type(compact):

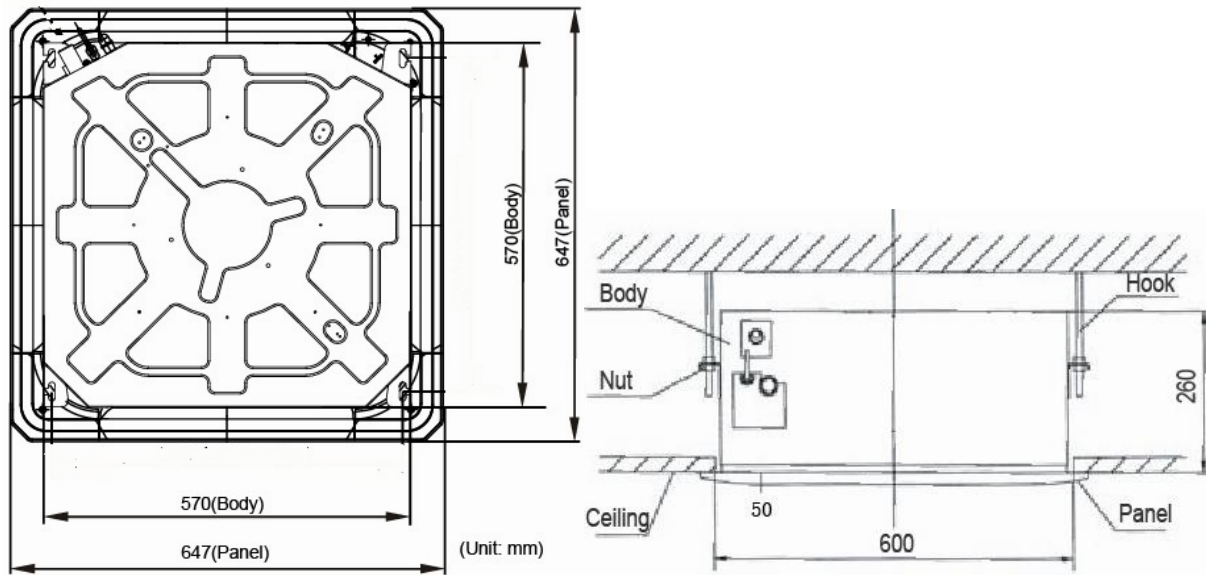

### 2.2 A5 Duct

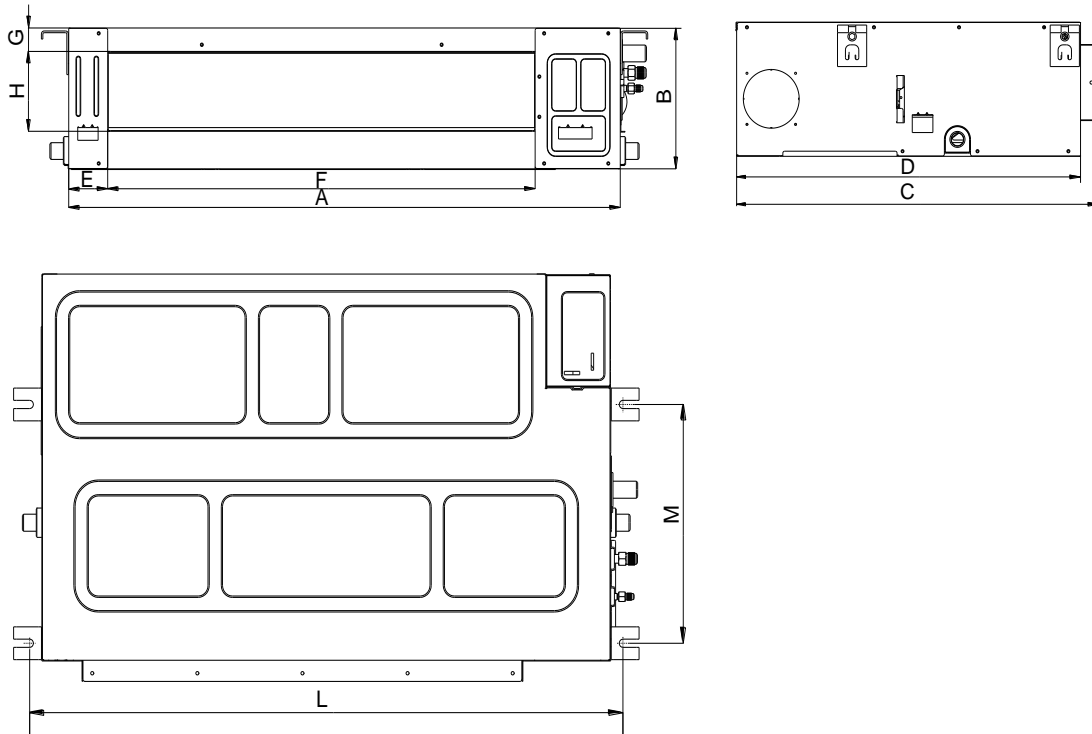

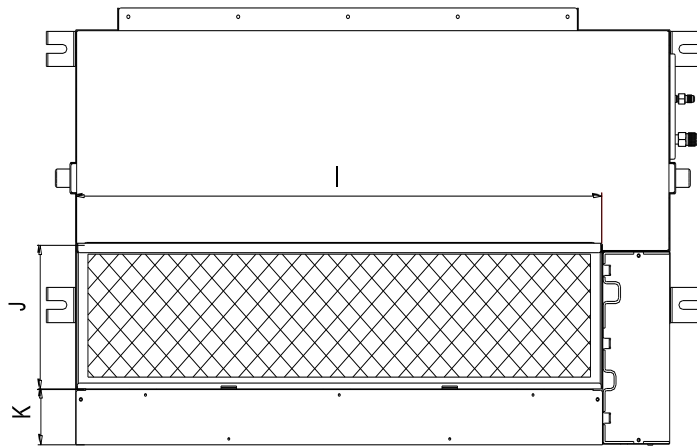

Model	Outline dimension(mm)				Air outlet opening size				Air return opening size			Size of outline dimension mounted plug	
	A	B	C	D	E	F	G	H	I	J	K	L	M
AWSI-DCD012-N11	700	210	635	570	65	493	35	119	595	200	80	740	350

### 2.3 Console

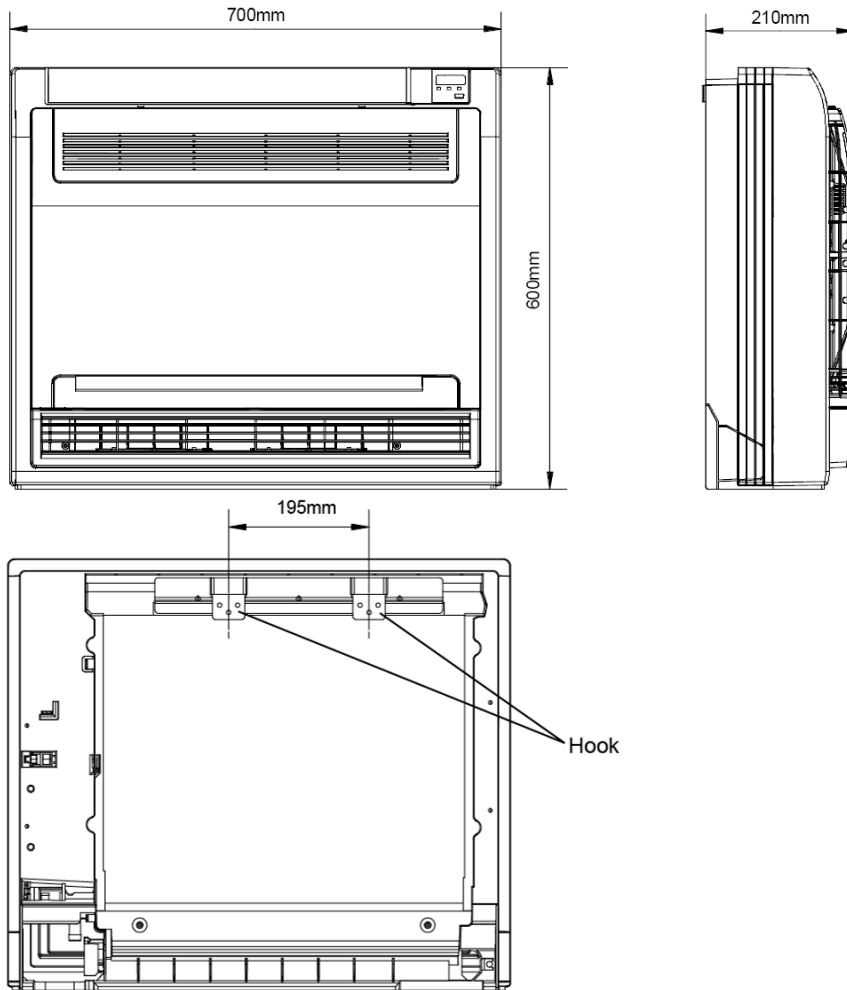

### 3. Service Space(unit:mm)

#### 3.1 Four-way cassette(compact)

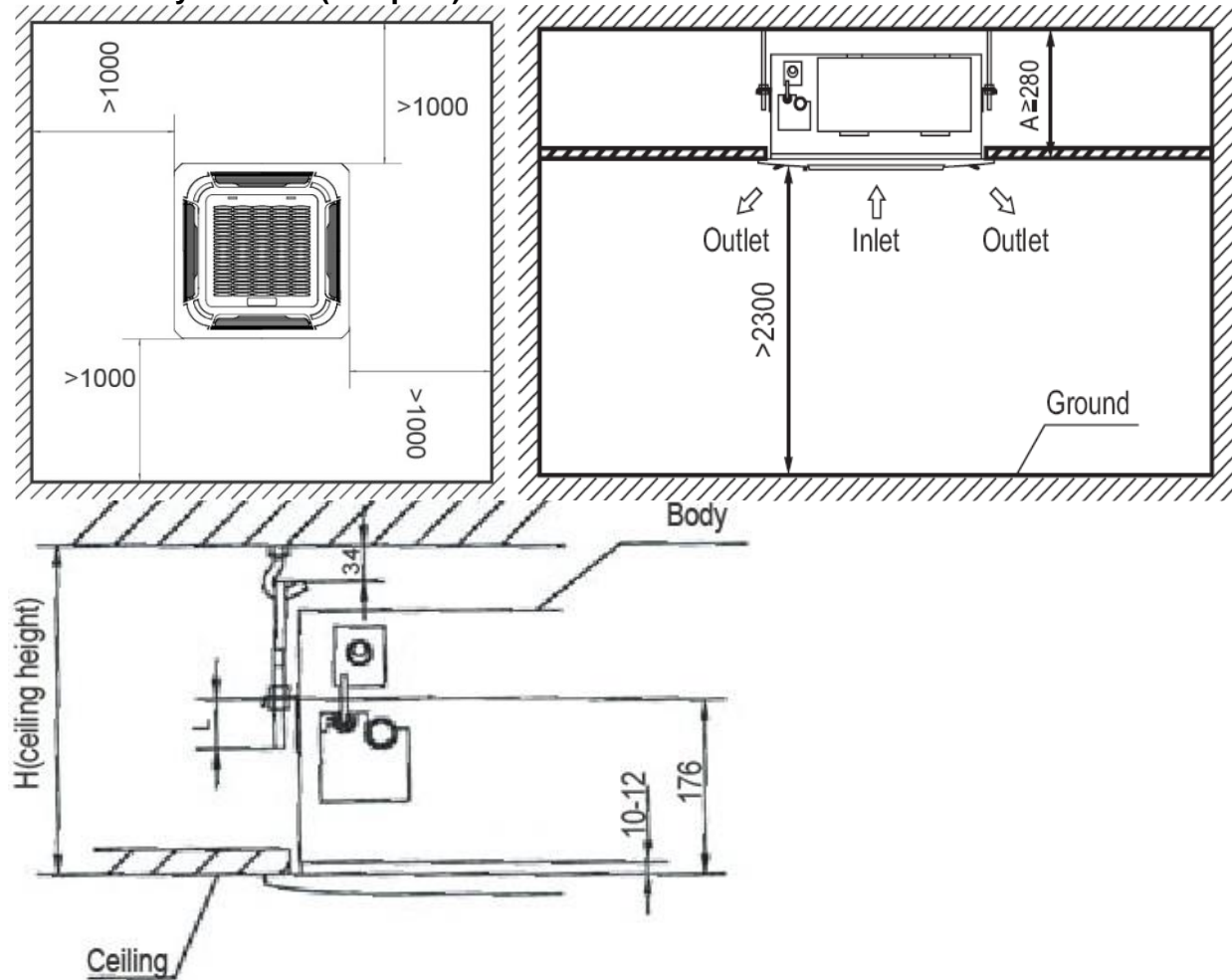

#### 3.2 A5 Duct

Ensure enough space required for installation and maintenance.

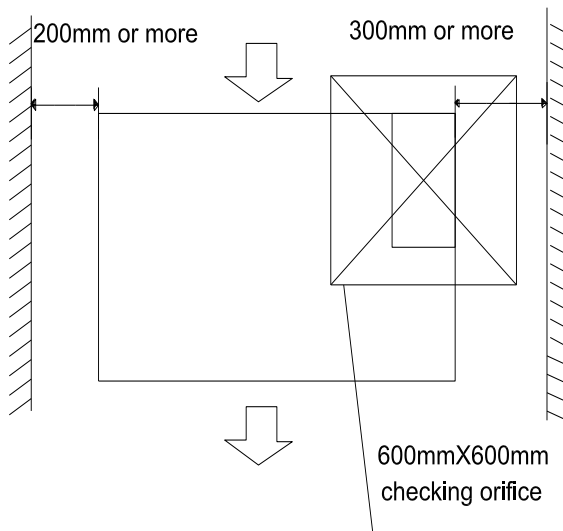

All the indoor units reserve the hole to joint the fresh air pipe. The hole size as following:

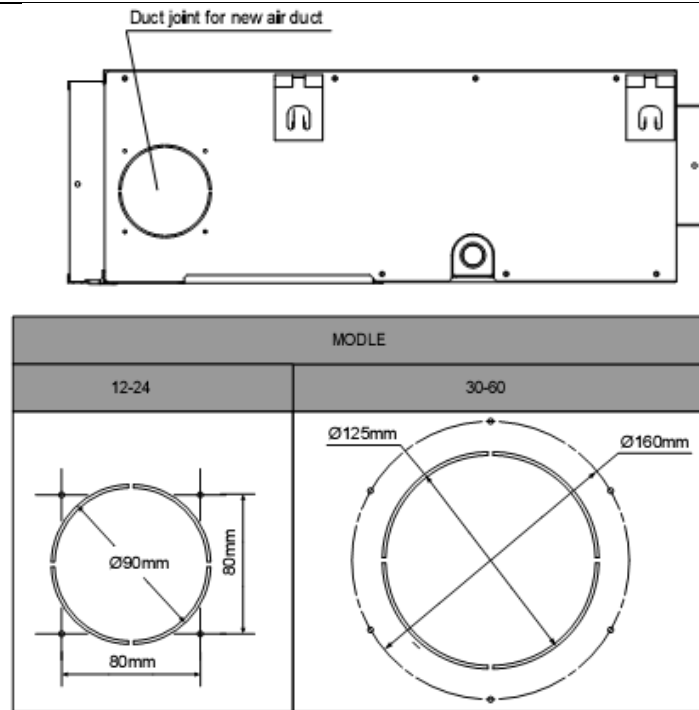

### 3.3 Console

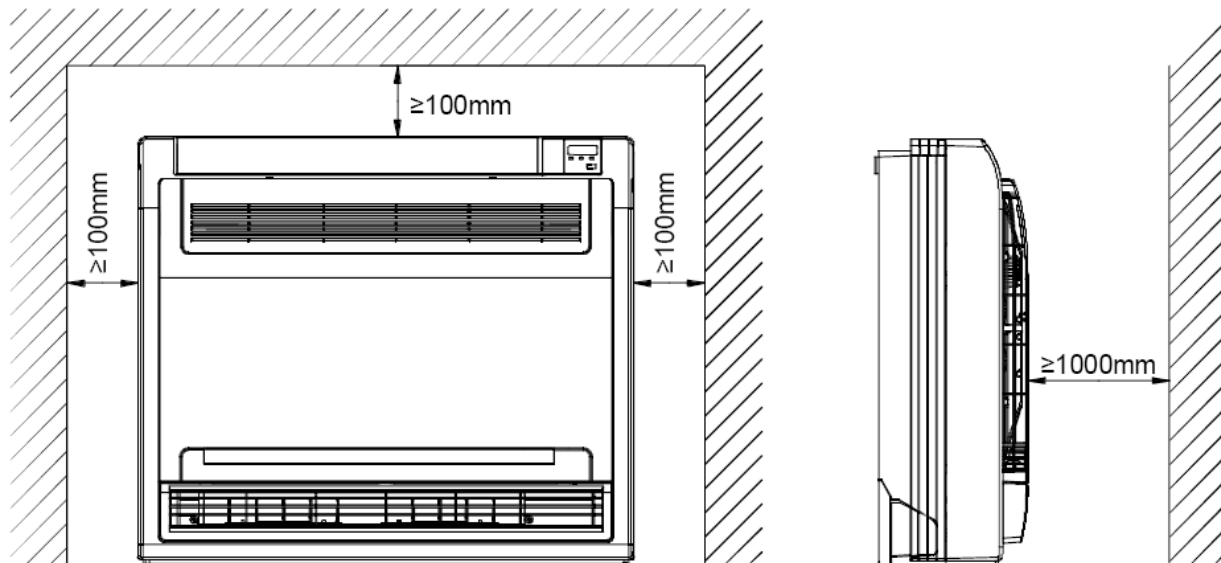

### 4. Wiring Diagrams



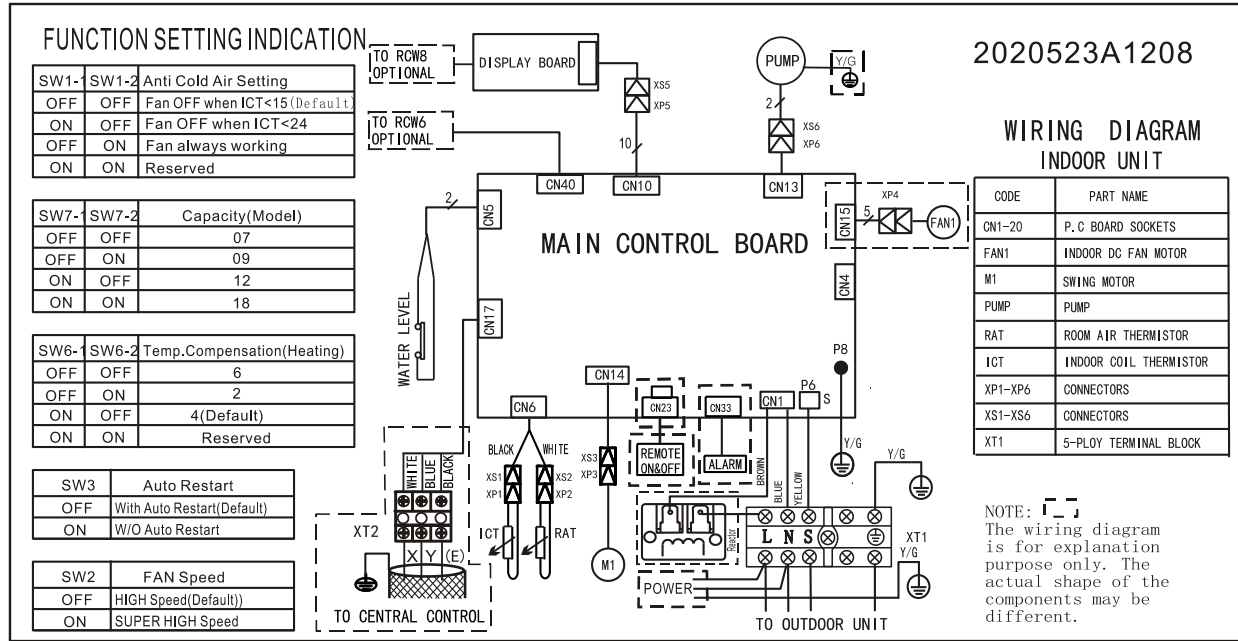



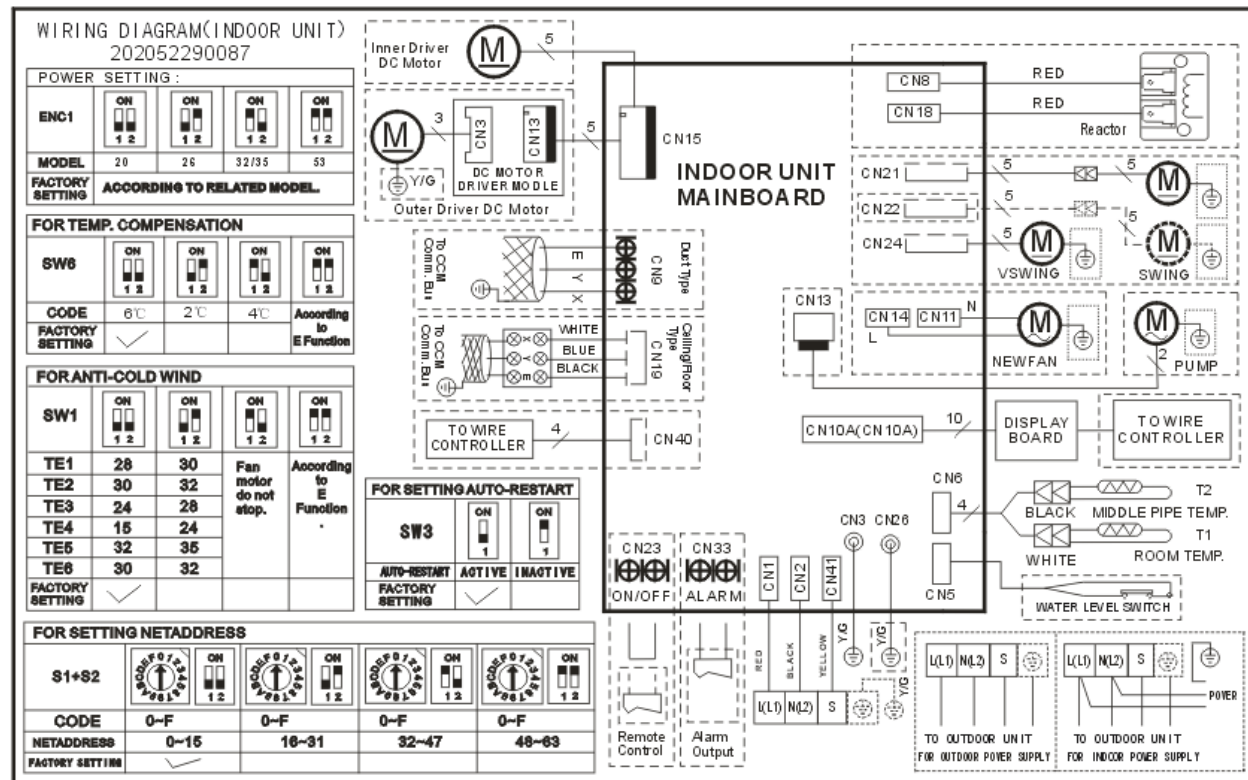























#### AWSI-CBD012-N11



#### AWSI-DCD012-N11



AWSI-DCD012-N11

<b>FOR SETTING POWER</b>							<b>FOR MAIN-SLAVE SETTING</b>					
ENC1								SW1				
CODE	4	5	7	8	9	A	B	MODE	MAIN NO SLAVE	MAIN	MAIN	SLAVE
Power	53	71	90	105	140	160	175	FACTORY SETTING	<input checked="" type="checkbox"/>			
FACTORY SETTING	ACCORDING TO RELATED MODEL.											
<b>FOR SETTING NETADDRESS</b>							<b>FOR SETTING FAN MOTOR CONTROL THEN NO POWER REQUEST</b>					
S1+S2							SW2					
CODE	0~F	0~F	0~F	0~F	0~F	0~F	MODE	FAN OFF	FAN ON			
NETADDRESS	0~15	16~31	32~47	48~63			FACTORY SETTING	<input checked="" type="checkbox"/>				
FACTORY SETTING	<input checked="" type="checkbox"/>											
<b>FOR SETTING STATIC PRESSURE</b>					<b>FOR TEMP. COMPENSATION</b>							
ENC2						SW6						
Code	0	1	2	3	4	DUCT TYPE	3℃	4℃	6℃			
HIGH STATIC PRESSURE	0~50	51~80	81~120	121~150	>150	CEILING AND FLOOR TYPE	1℃	4℃	6℃	According to E Function		
MIDDLE STATIC PRESSURE	0~25	26~37	38~50	51~100	>100	FOR SETTING CEILING TYPE OR FLOOR TYPE	FLOOR TYPE	CEILING TYPE				
FACTORY SETTING	<input checked="" type="checkbox"/>					FACTORY SETTING	<input checked="" type="checkbox"/>					
<b>FOR SETTING AUTO-RESTART</b>			<p style="text-align: center; font-weight: bold;">202070290383 FUNCTION SETTING INDICATION</p>									
SW3												
AUTO-RESTART	ACTIVE	INACTIVE										
FACTORY SETTING	<input checked="" type="checkbox"/>											

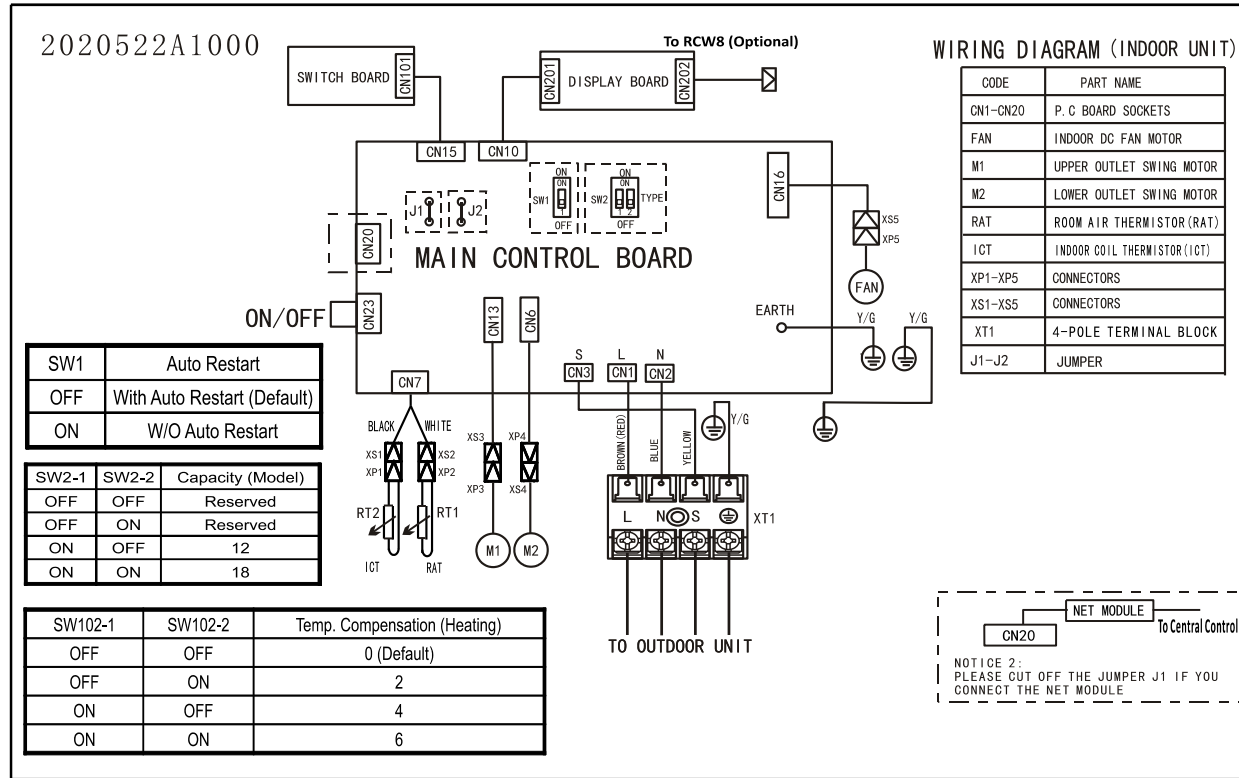



### 5. Exploded View and Spare Part list

Exploded View of indoor unit:AWSI-CBD012-N11

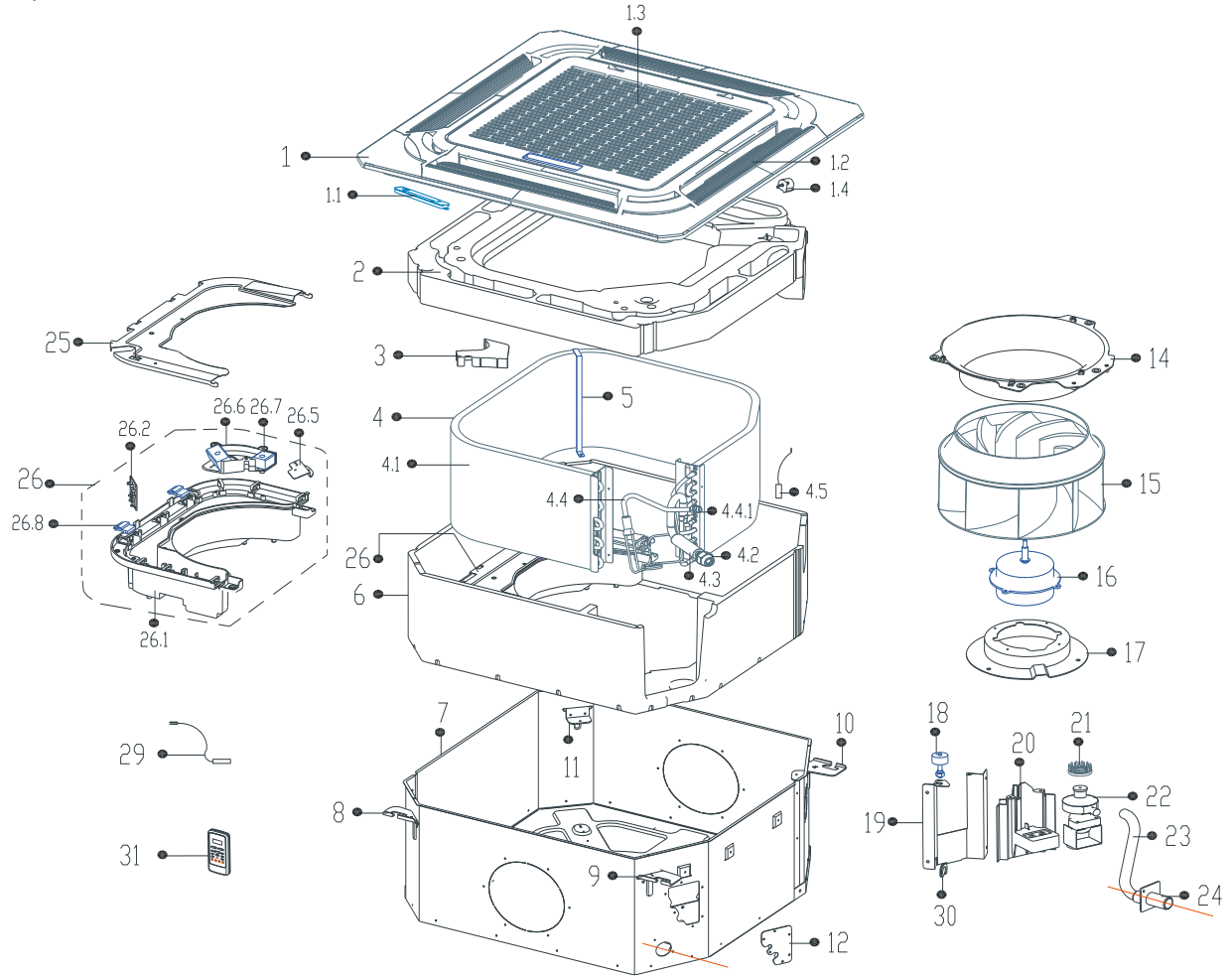

## Spare part list of indoor unit:AWSI-CBD012-N11

No.	Part Name	Qty	BOM Code	No.	Part Name	Qty	BOM Code
1	Panel	1	2011099A2555	14	Ventilation ring	1	201142390003
1.1	Display box assembly	1	203342090008	15	Centrifugal fan	1	201100100804
1.2	Horizontal louver	4	201109991797	16	Asynchronous motor	1	202400300052
1.3	Air filter	1	P0000453127	17	Fan motor fixing base	1	201280490338
1.4	Louver motor	1	202400280001	18	Water level switch	1	202301800916
2	Water collector	1	202280490006	19	Evaporator fixing board	1	201280490337
3	Wire box	1	201180490047	20	Drain pump installation base	1	201180490049
4	Evaporator assembly	1	201552390007	21	Guard against block up net	1	201180490041
4.1	Evaporator	1	201542390002	22	Drain pump	1	202400600005
4.2	Copper nut	1	201600320001	23	Drain pipe	1	202742390002
4.3	Output pipe assembly	1	201652390020	24	Drain connecting pipe	1	201101030002
4.4	Input pipe assembly	1	201642390001	25	Cover of electronic control box	1	201280490491
4.4.1	Copper nut	1	201600320000	26	Electronic control box assembly	1	203342390100
4.5	Pipe temperature sensor assembly	1	202301300445	26.1	Electronic control box	1	201180490043
5	Evaporator hang board	1	201280490336	26.2	Main control board assembly	1	201342390100
6	Base foam assembly	1	202280490005	26.5	Insulation plate	1	201280490471
7	Chassis assembly	1	201242390003	26.6	Installation base of terminal	1	201180490044
8	Hook II	1	201280490483	26.7	Wire joint	1	202301450119
9	Hook I	1	201280490482	26.8	Clip	3	201180490045
10	Hook IV	1	201280490485	29	Ambient temperature sensor assembly	1	202301310075
11	Hook III	1	201280490484	30	Rubber guard bush	1	202780490007
12	Pipe fixing board assembly	1	201142390001	31	Remote controller	1	203355091552

Exploded View of indoor unit: AWSI-DCD012-N11

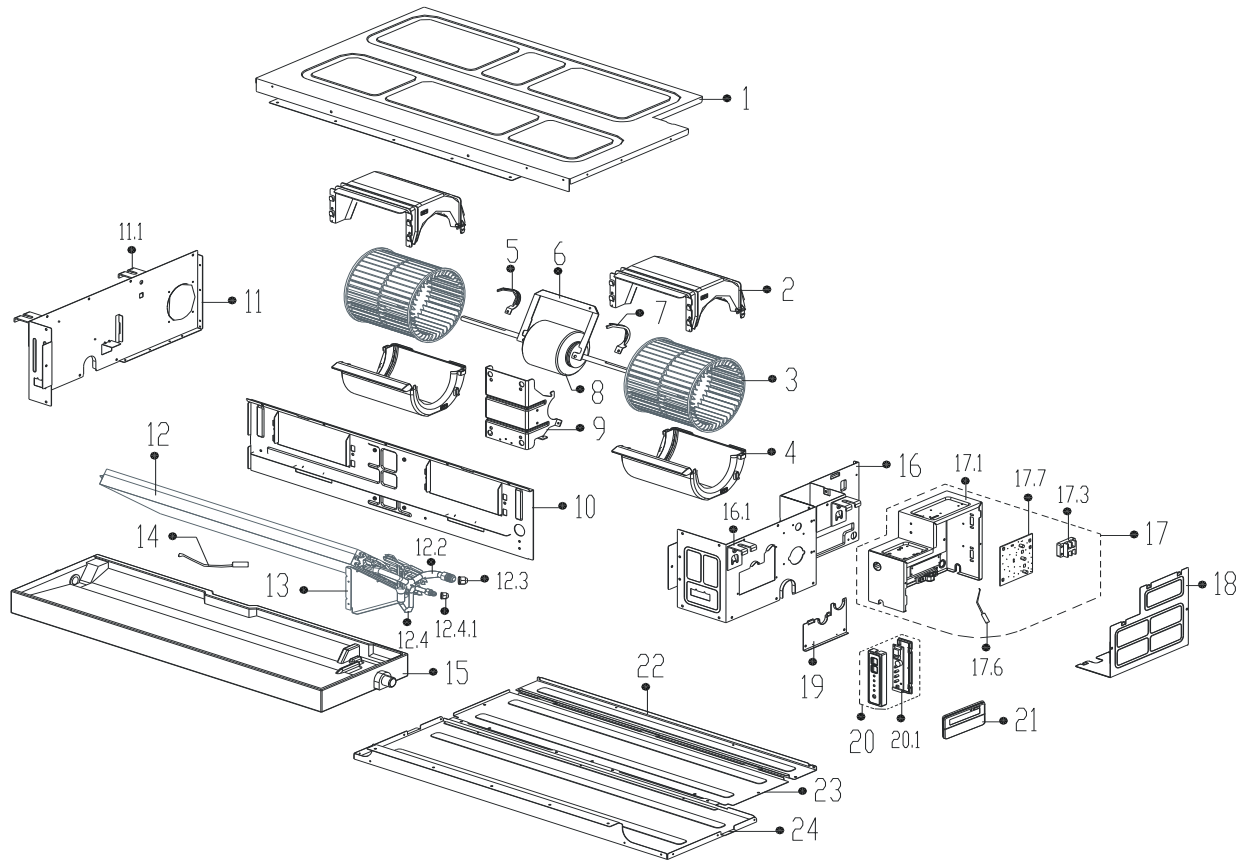

## Spare part list of indoor unit: AWSI-DCD012-N11

No.	Part Name	Qty	BOM Code	No.	Part Name	Qty	BOM Code
1	Chassis assembly	1	201285190007	14	Pipe temperature sensor assembly	1	202440500004
2	Up volute shell	2	201185190001	15	Water collector	1	202285190003
3	Centrifugal fan	2	201100100809	16	Right clapboard assembly	1	201270290089
4	Below volute shell	2	201185190002	16.1	Hook	2	201270890021
5	Fan motor axes clamp (left)	1	201280200005	17	Electronic control box assembly	1	203370190015
6	Fan motor fixing board	1	201252490002	17.1	Electronic control box	1	201270290163
7	Fan motor axes clamp (right)	1	201280200006	17.3	Wire joint	1	202301450003
8	Asynchronous motor	1	202400300053	17.6	Ambient temperature sensor assembly	1	202301310075
9	Supporter of fan motor	1	201252290005	17.7	Main control board assembly	1	201352290020
10	Middle beam assembly	1	201285190002	18	Cover of electronic control box	1	201270290081
11	Left clapboard assembly	1	201270290091	19	Pipe clamp board assembly	1	201270290082
11.1	Hook	2	201270890021	20	Display box assembly	1	203370190008
12	Evaporator assembly	1	201552290012	20.1	Display board assembly	1	201370290012
12.2	Output pipe assembly	1	201652290013	21	Wired controller	1	2033551A2826
12.3	Copper nut	1	201600320001	22	Rear beam	1	201285190003
12.4	Input pipe assembly	1	201670190020	23	Rear cover assembly	1	201285190004
12.4.1	Copper nut	1	201600320000	24	Top cover assembly	1	201285190008
13	Evaporator right support board assembly	1	201270290034				

Exploded View of indoor unit:AWSI-XAD012-N11

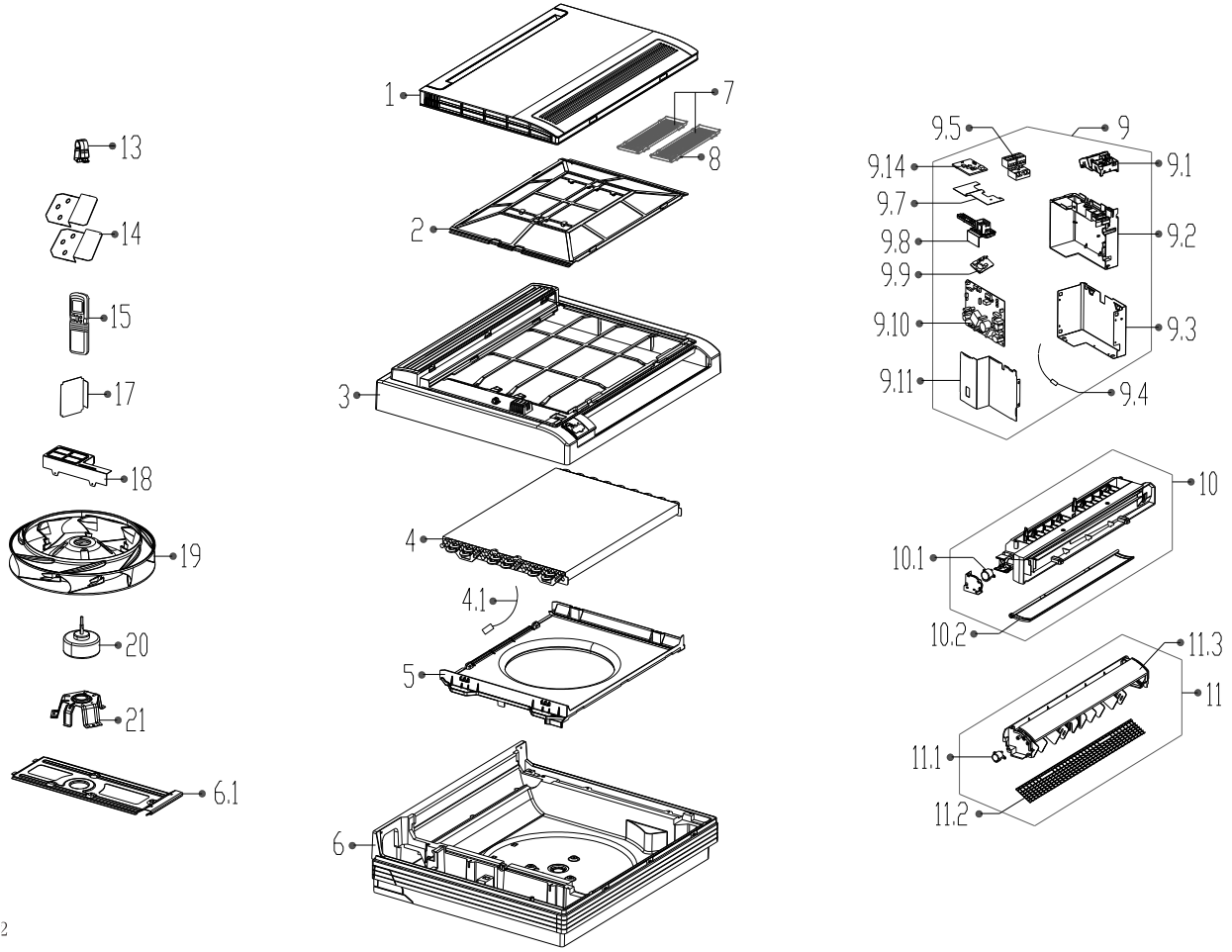

## Spare part list of indoor unit:AWSI-XAD012-N11

No.	Part Name	Qty	BOM Code	No.	Part Name	Qty	BOM Code
1	Panel assembly	1	2011440A0001	9.10	Main control board assembly	1	2013440A0029
2	Air filter	1	201144090002	9.11	Fixing board of electronic control box I	1	201244090004
3	Panel assembly frame	1	201144090022	9.14	Auxiliary electric heater control board	1	201344090029
4	Evaporator assembly	1	201544090014	10	Water collector	1	201144090044
4.1	Pipe temperature sensor assembly	1	202301310085	10.1	Louver motor	1	202400200052
5	Ventilation assembly	1	201144090030	10.2	Underside louver	1	P0000281380
6	Chassis assembly	1	201144090016	11	Air outlet assembly	1	201144090042
6.1	Hang board assembly	1	201244090009	11.1	Louver motor	1	202400200053
7	Anti-bacterial filter	2	201131410703	11.2	Rear net	1	201244090008
8	Bracket of air filter	2	201132200713	11.3	Up louver	1	P0000283050
9	Electronic control box assembly	1	2033440A0034	13	Pipe clamp	1	201144090011
9.1	Installation plate of electric parts I	1	201144090009	14	Installation clamp	2	201244290015
9.2	Electrical control box	1	201144090010	15	Remote controller	1	203355091552
9.3	Fixing board of electronic control box II	1	201244090003	17	Insulation washer	1	201144090005
9.4	Ambient temperature sensor assembly	1	202301310072	18	Cover of electronic control box	1	201244090001
9.5	Wire joint	1	202301400072	19	Centrifugal fan	1	201100100020
9.7	Electronic control box seal plate	1	201244090002	20	Fan motor	1	202400300014
9.8	Installation plate of electric parts	1	201144090008	21	Supporter assembly of fan motor	1	201244090005
9.9	Display assembly board	1	201344090004				

# Part 3

## Outdoor Units

1. Dimensions.....	54
2. Service Space.....	58
3. Refrigeration Cycle Diagram.....	59
4. Wiring Diagrams .....	61
5. Indoor units combination.....	63
6. Operation Limits.....	64
7. Sound Levels.....	65
8. Exploded View and Spare Part list .....	66

# 1. Dimensions

## AWSI-XAD012-N11

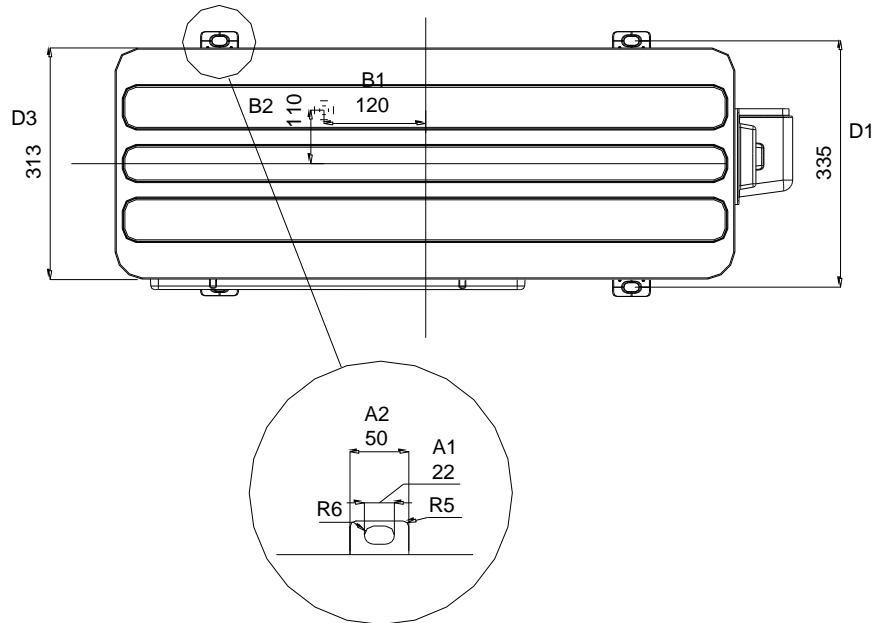
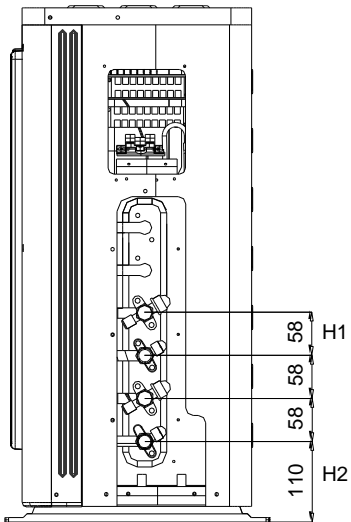
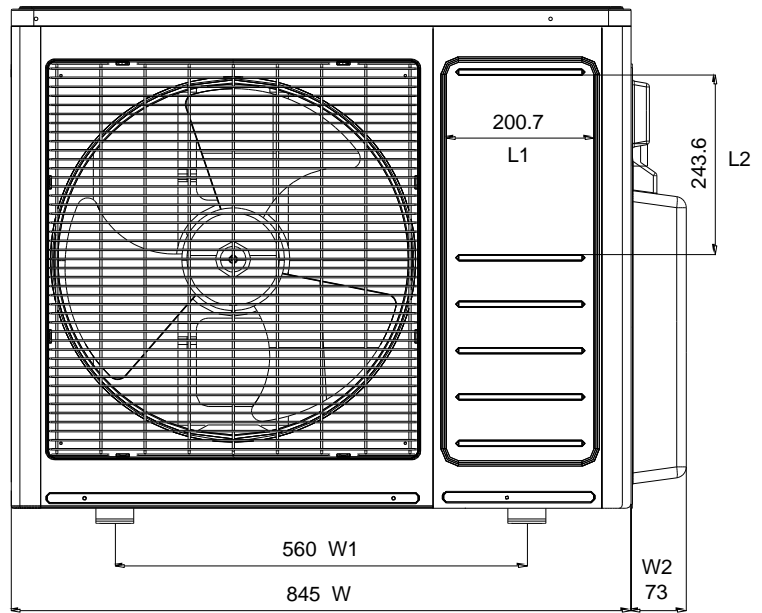
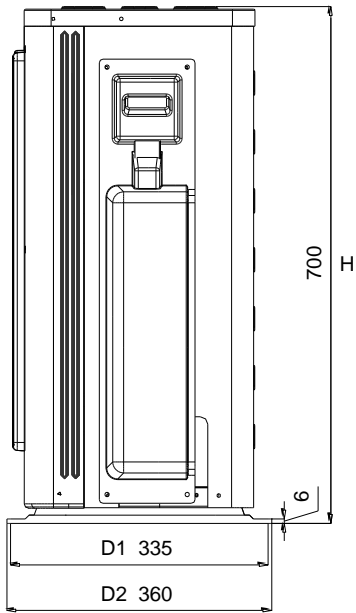



AWAU-YCZ327-H11

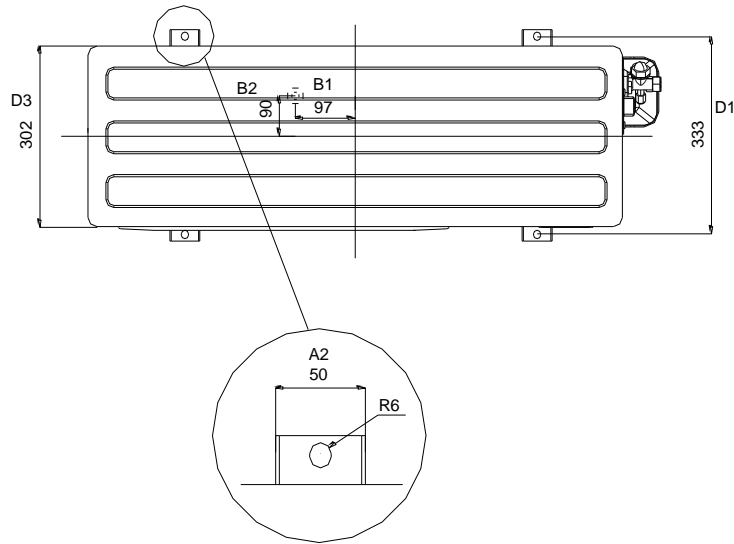
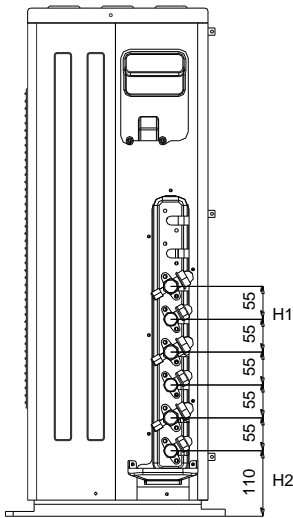
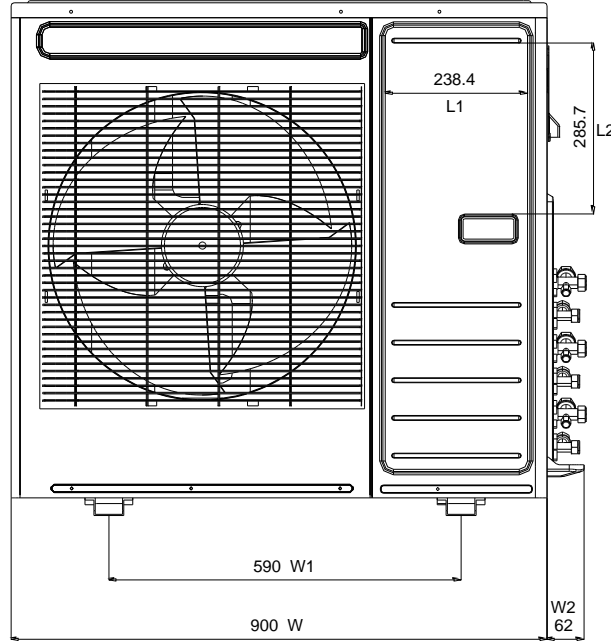
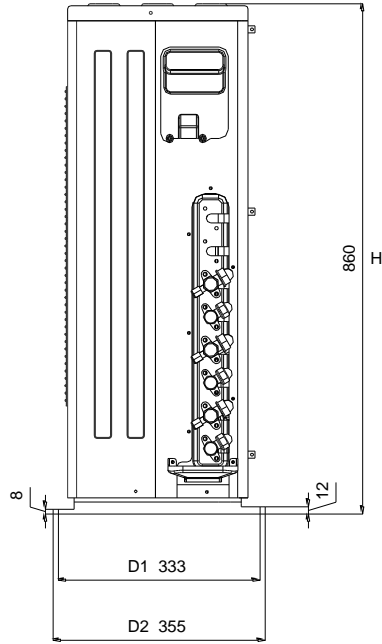

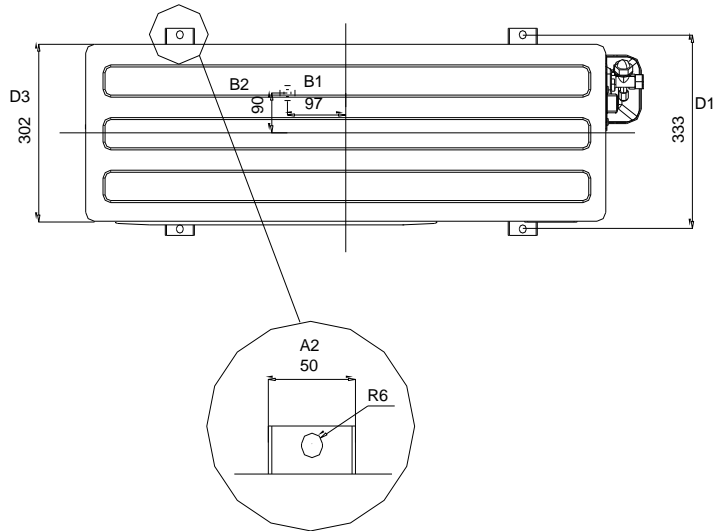
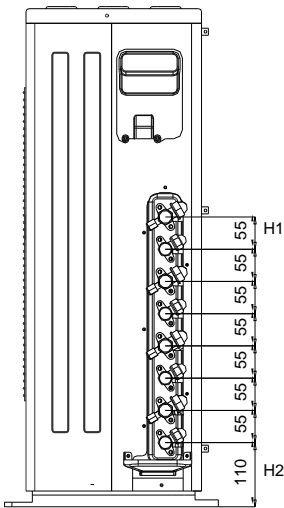
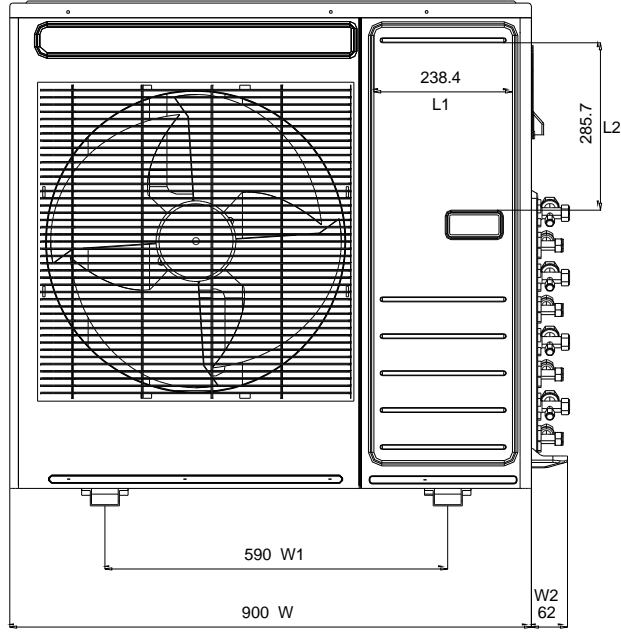
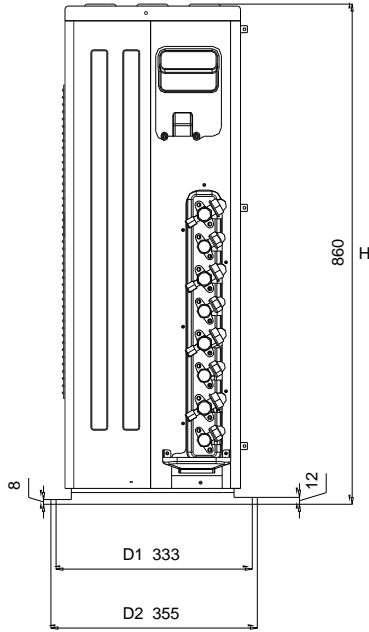

AWAU-YCZ536-H11

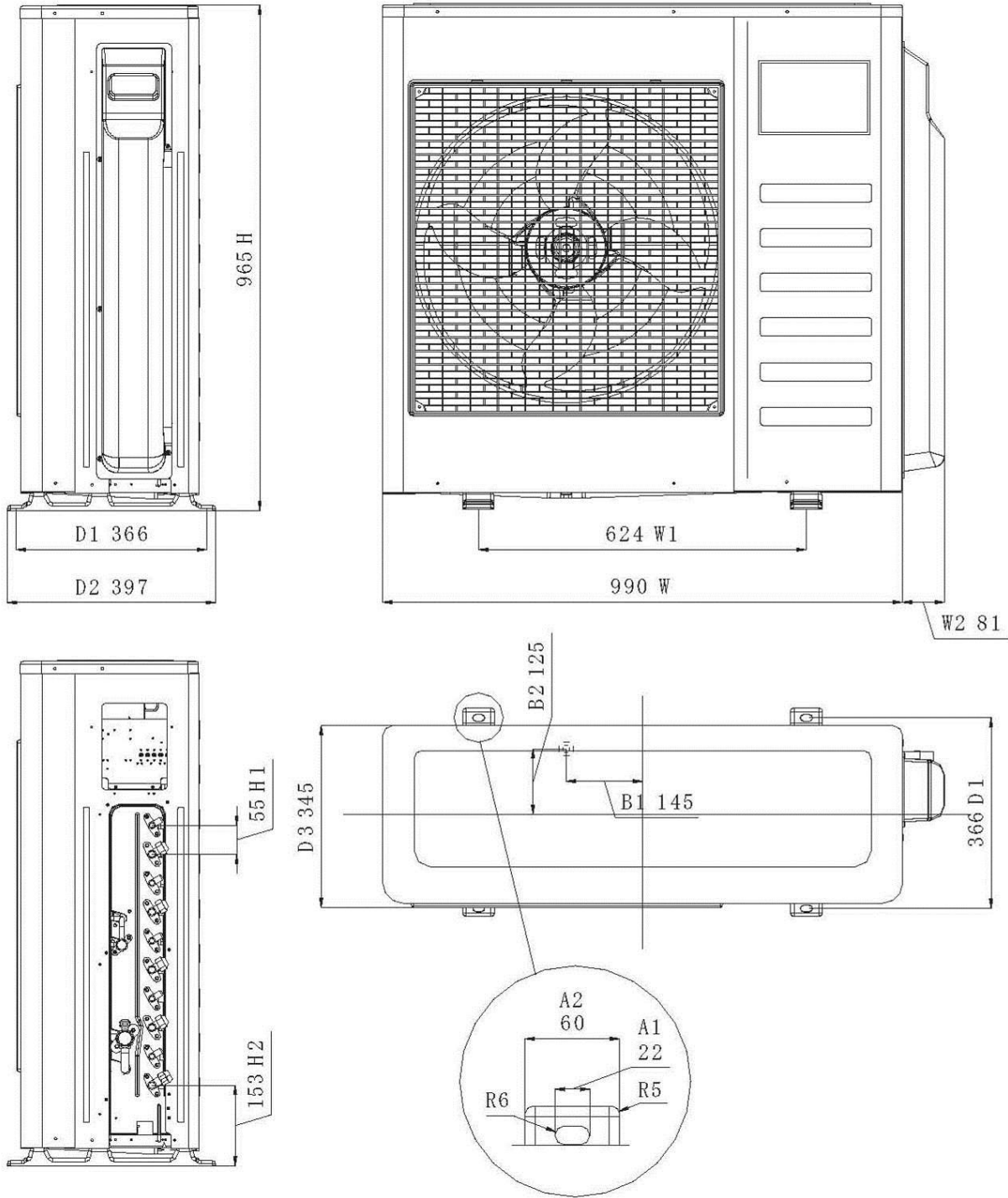

## 2. Service Space

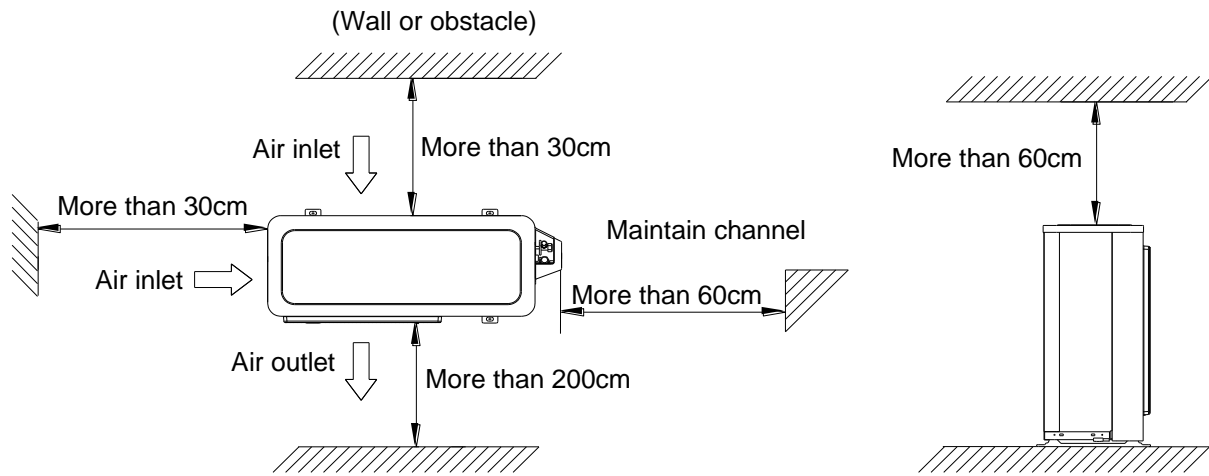

### 3. Refrigeration Cycle Diagram

#### 3.1 Refrigeration cycle diagram of inverter 1 drive 2 type

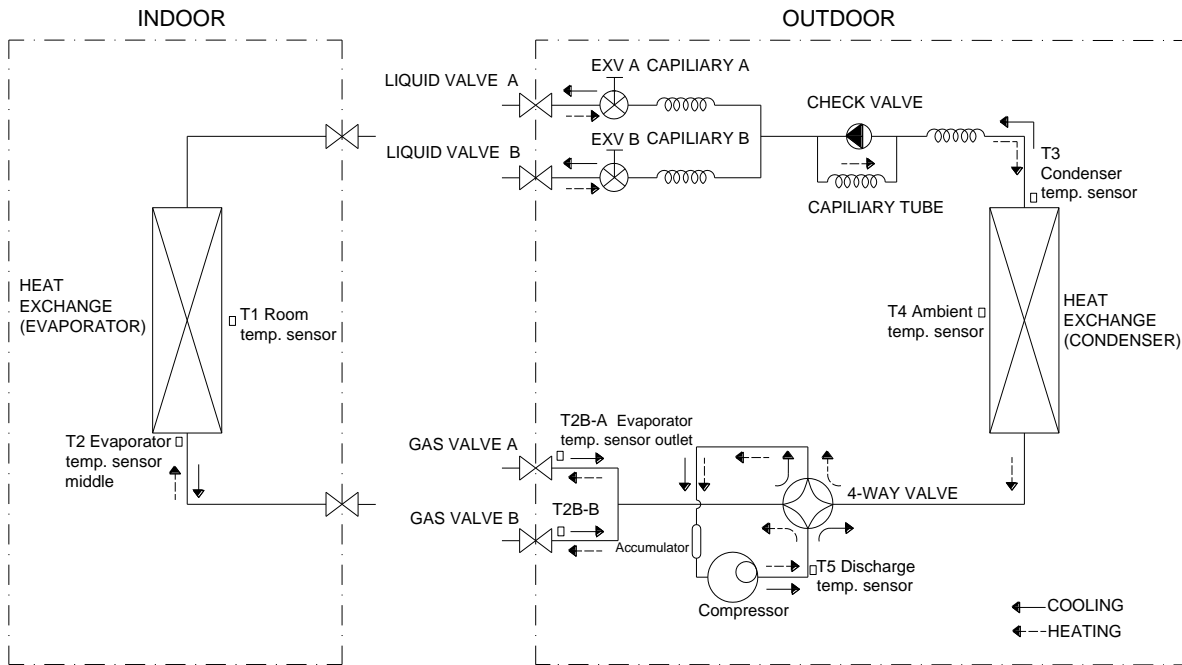

#### 3.2 Refrigeration cycle diagram of inverter 1 drive 3 type

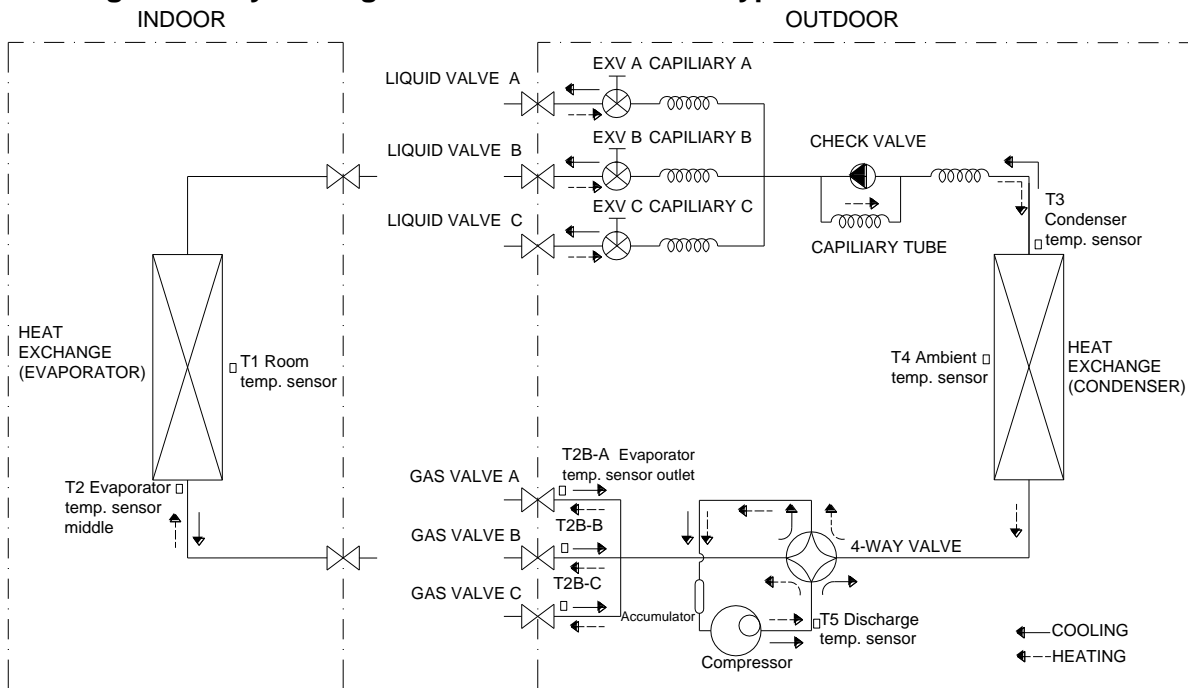

#### 3.3 Refrigeration cycle diagram of inverter 1 drive 4 type

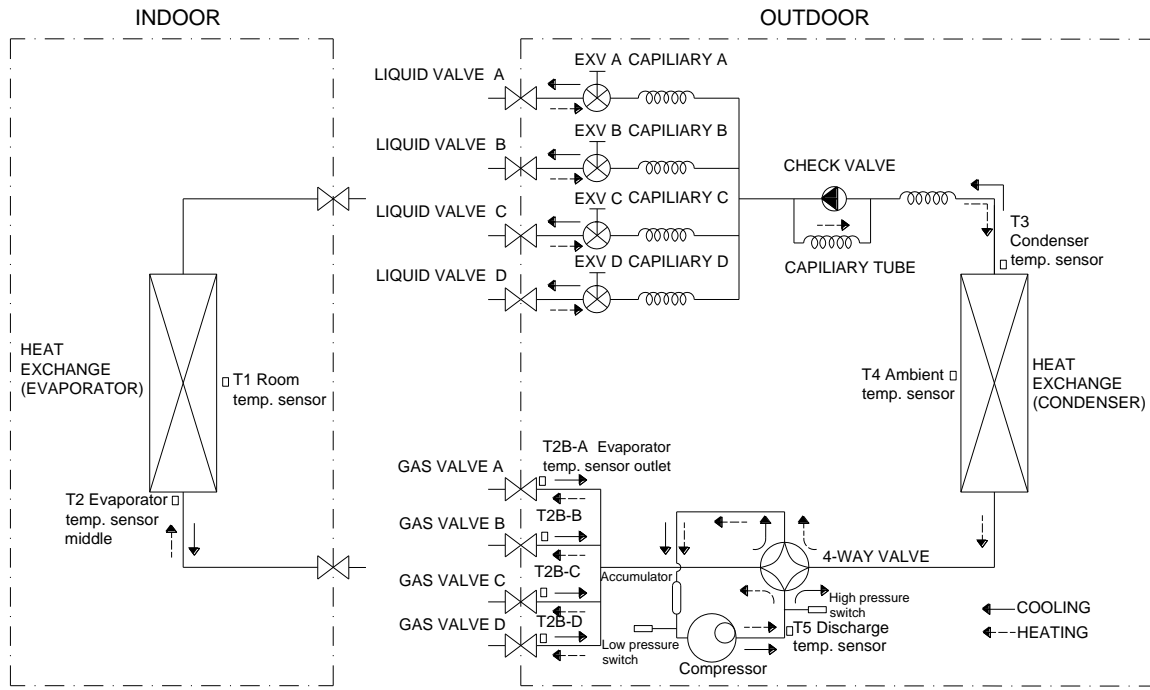

### 3.4 Refrigeration cycle diagram of inverter 1 drive 5 type

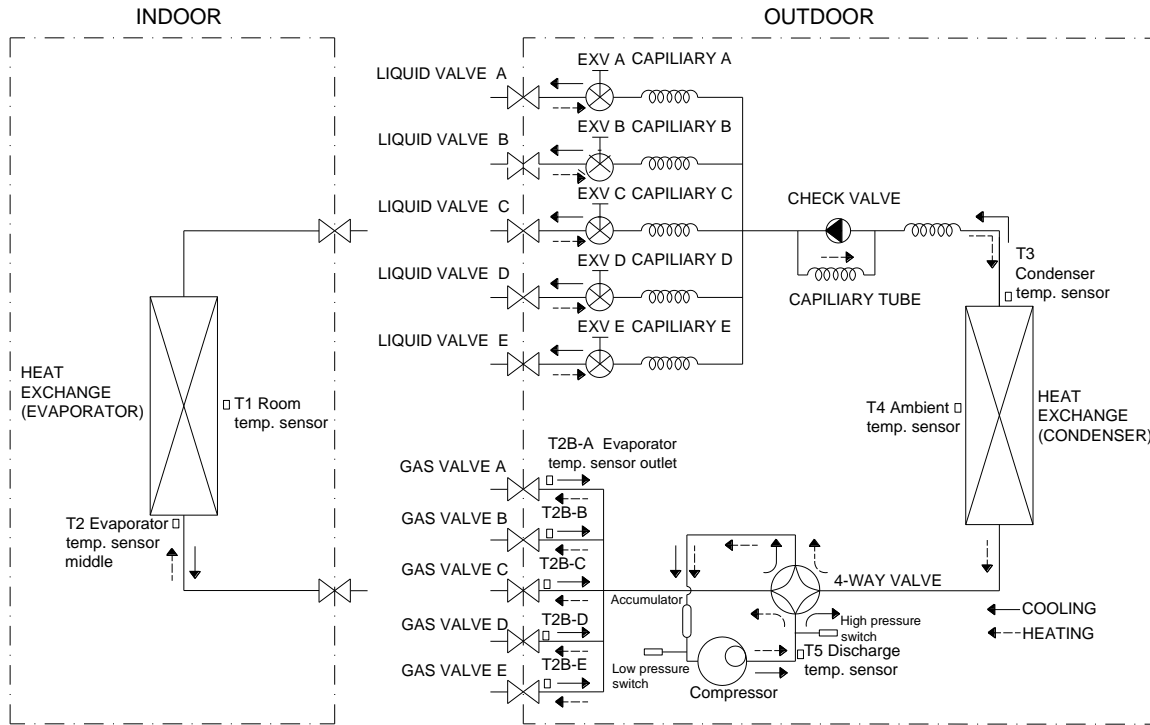

### 4. Wiring Diagrams

#### AWAU-YCZ218-H11

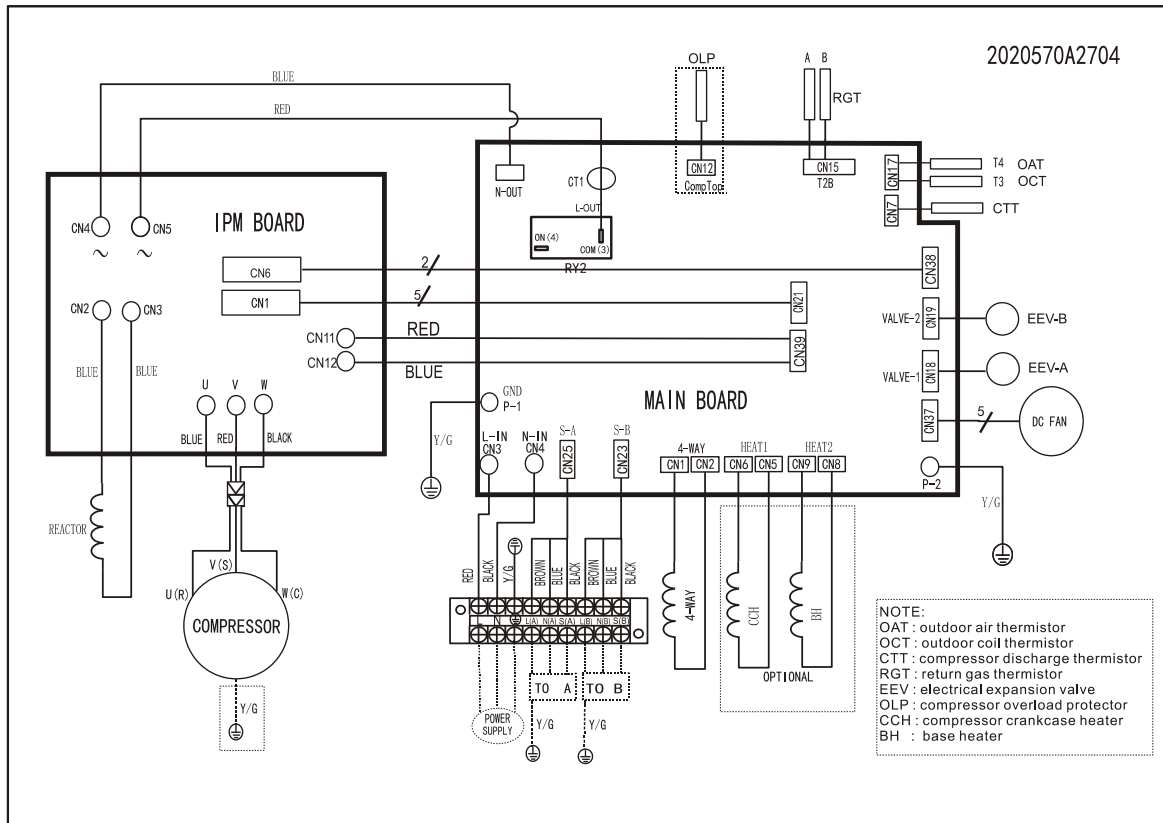

#### AWAU-YCZ327-H11

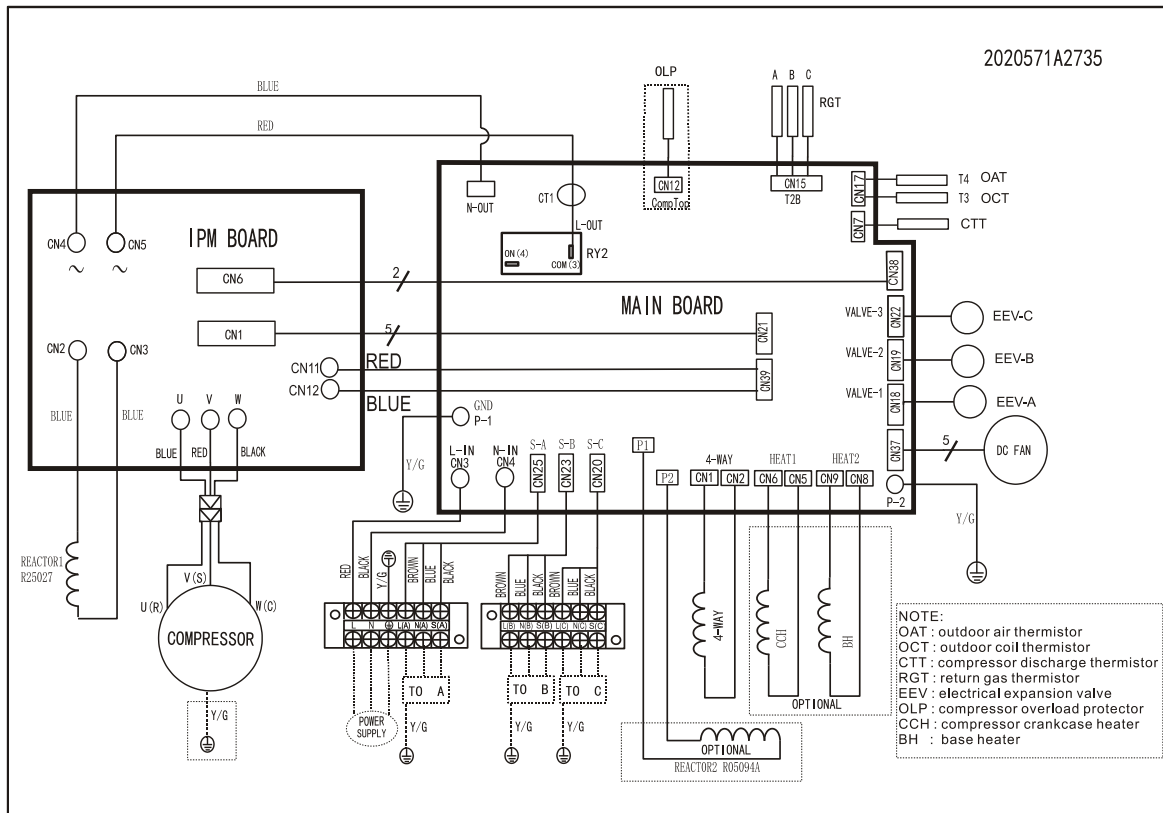

Wiring Diagrams  
AWAU-YCZ430-H11

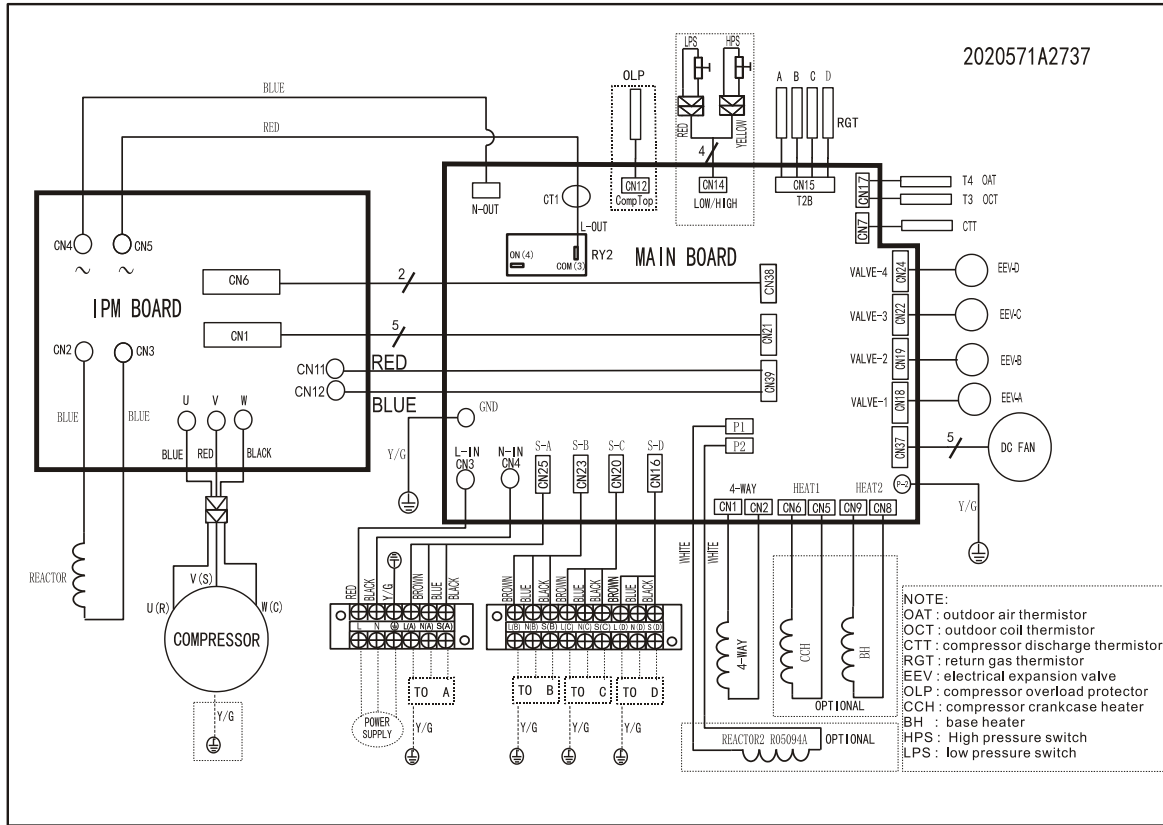

AWAU-YCZ536-H11

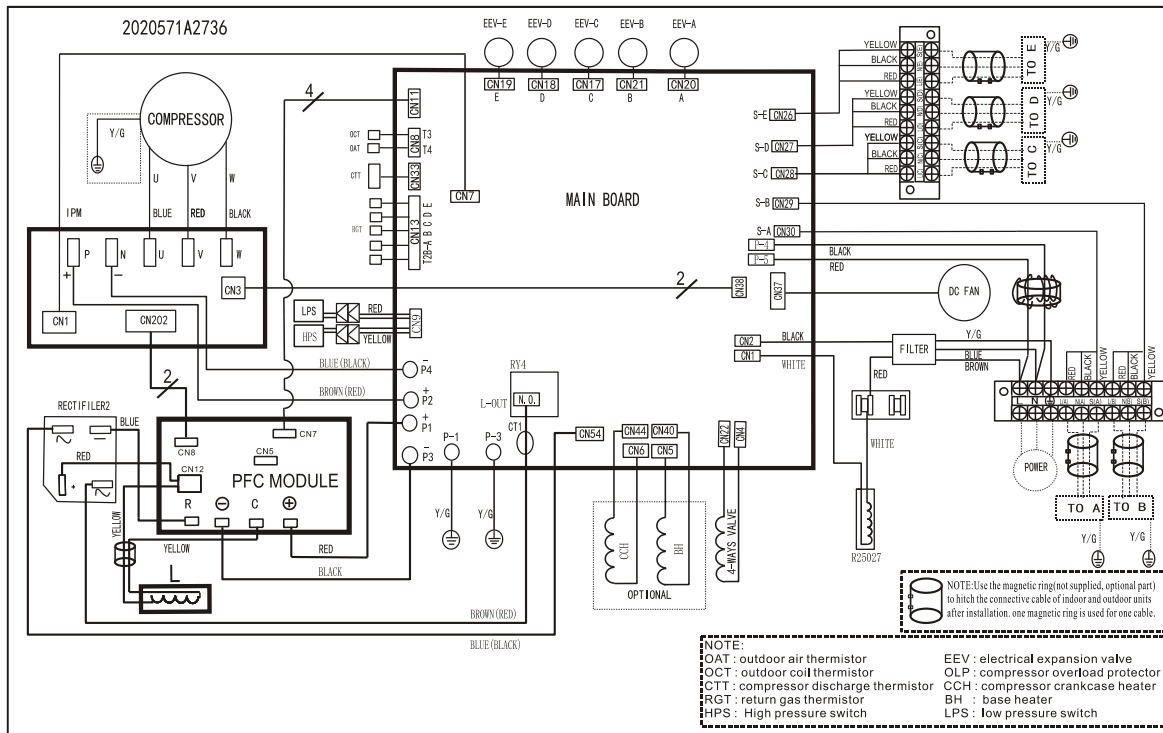



## 5. Indoor units combination

### 5.1 Indoor unit combination for AWAU-YCZ218-H11

AWAU-YCZ218-H11	
Two IDU	
9+9	
9+12	
9+18	
12+12	

### 5.2 Indoor unit combination for AWAU-YCZ327-H11

AWAU-YCZ327-H11		
Two IDU	Three IDU	
9+18	9+9+9	9+12+12
12+18	9+9+12	9+12+18
18+18	9+9+18	12+12+12

### 5.3 Indoor unit combination for AWAU-YCZ430-H11

AWAU-YCZ430-H11			
Two IDU	Three IDU		Four IDU
9+18	9+9+9	9+12+12	9+9+9+9
12+18	9+9+12	9+12+18	9+9+9+12
18+18	9+9+18	12+12+12	

### 5.4 Indoor unit combination for AWAU-YCZ536-H11

AWAU-YCZ536-H11							
Two IDU	Three IDU		Four IDU			Five IDU	
18+18	9+9+18	12+12+12	9+9+9+9	9+9+12+12	9+12+12+18	9+9+9+9+9	9+9+9+12+18
	9+12+12	12+12+18	9+9+9+12	9+9+12+18	12+12+12+12	9+9+9+9+12	9+9+12+12+12
	9+12+18	12+18+18	9+9+9+18	9+9+18+18	12+12+12+18	9+9+9+9+18	9+12+12+12+12
	9+18+18	18+18+18		9+12+12+12		9+9+9+12+12	12+12+12+12+12

## 6. Operation Limits

Mode \ Temperature	Cooling operation	Heating operation
Room temperature	$\geq 17^{\circ}\text{C}$	$\leq 30^{\circ}\text{C}$
Outdoor temperature	$0^{\circ}\text{C} \sim 50^{\circ}\text{C}$	$-15^{\circ}\text{C} \sim 24^{\circ}\text{C}$
	$-15^{\circ}\text{C} \sim 50^{\circ}\text{C}$ (For the models with low temperature cooling system)	

**CAUTION:**

1. If the air conditioner is used beyond the above conditions, certain safety protection features may come into operation and cause the unit to operate abnormally.
2. The room relative humidity should be less than 80%. If the air conditioner operates beyond this figure, the surface of the air conditioner may attract condensation. Please set the vertical air flow louver to its maximum angle (vertically to the floor), and set HIGH fan mode.
3. The optimum performance will be achieved during this operating temperature zone.

## 7. Sound Levels

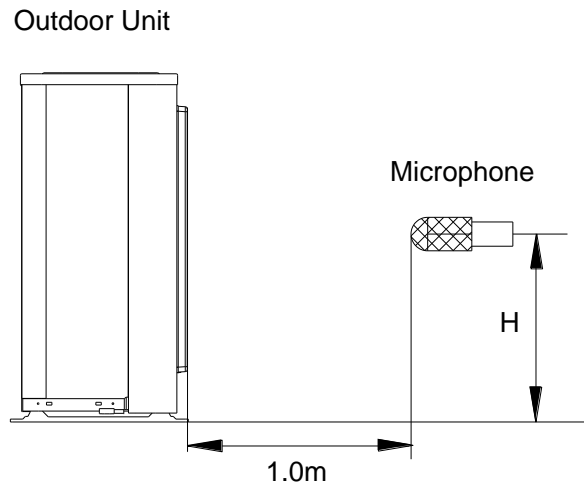

**Note:** H= 0.5 x height of outdoor unit

Model	Noise Power dB(A)	Noise level dB(A)
AWAU-YCZ218-H11	65	60
AWAU-YCZ327-H11	68	61
AWAU-YCZ430-H11	70	62
AWAU-YCZ536-H11	70	64

## 8. Exploded View and Spare Part list

Exploded View of outdoor unit: AWAU-YCZ218-H11

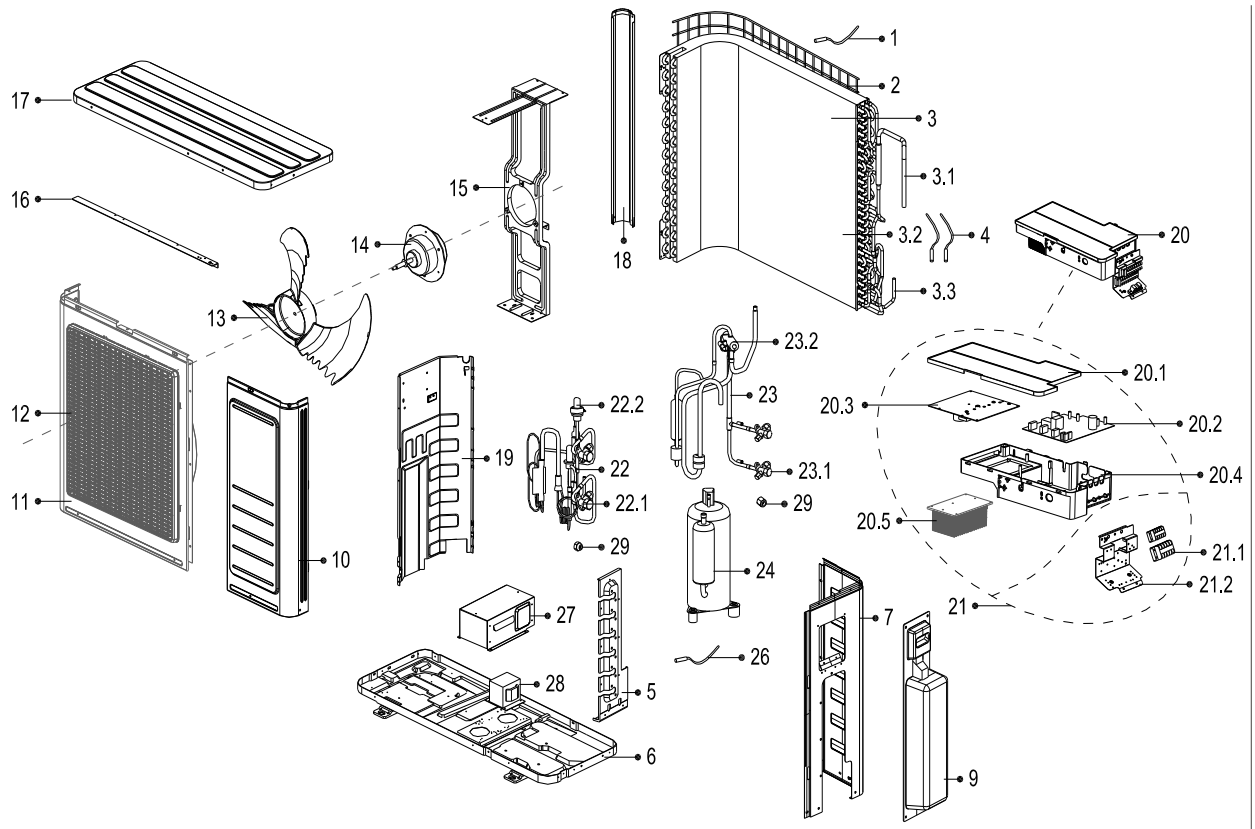

## Spare part list of outdoor unit: AWAU-YCZ218-H11

No.	Part Name	Qty	BOM Code	No.	Part Name	Qty	BOM Code
1	Ambient temperature sensor assembly	1	202301310075	19	Partition board assembly	1	201257190118
2	Rear net	1	2011481G0001	20	Electronic control box assembly	1	203357090061
3	Condenser assembly	1	201537990084	20.1	Cover of electronic control box	1	201157190011
3.1	Input pipe assembly	1	201637991011	20.2	Outdoor main control board assembly	1	201357090064
3.2	Condenser	1	201537990003	20.3	Inverter control board assembly	1	201357190108
3.3	Output pipe	1	201637991010	20.4	Installation plate of electric parts	1	201157190010
4	Pipe temperature sensor assembly	1	202301300423	20.5	Radiator	1	202301901173
4	Pipe temperature sensor assembly	1	202440500004	21	Terminal board assembly	1	203357090057
5	Valve plate	1	201257190109	21.1	Wire joint	1	202301450157
6	Chassis assembly	1	201257090054	21.2	Terminal board	1	201257190117
7	Rear right clapboard assembly	1	201257190099	22	Liquid valve assembly	1	201657090490
9	Water collector	1	201157090005	22.1	Liquid valve	2	201600740097
10	Front right clapboard assembly	1	201248100389	22.2	Electronic expansion valve assembly	2	201601300554
11	Front panel	1	201248100390	23	4-ways valve assembly	1	201657090491
12	Air outlet grille	1	2011379A0005	23.1	Gas valve	2	201600720091
	Round sticker of air outlet grille	1	2011374A0005	23.2	4-ways valve	1	201600690011
13	Axial flow fan	1	201100300553	24	Compressor	1	201400600530
14	Brushless DC Motor	1	202400300535	26	Discharge temperature sensor assembly	1	202448200000
15	Supporter assembly of fan motor	1	201257090067	27	Cover of inductance	1	201248090001
16	Rear supporter	1	201248100384	28	Reactor	1	202301000943
17	Top cover assembly	1	201257190097	29	Copper nut	2	201600320000
18	Left supporter	1	201248100367	19	Partition board assembly	1	201257190118

Exploded View of outdoor unit: AWAU-YCZ327-H11

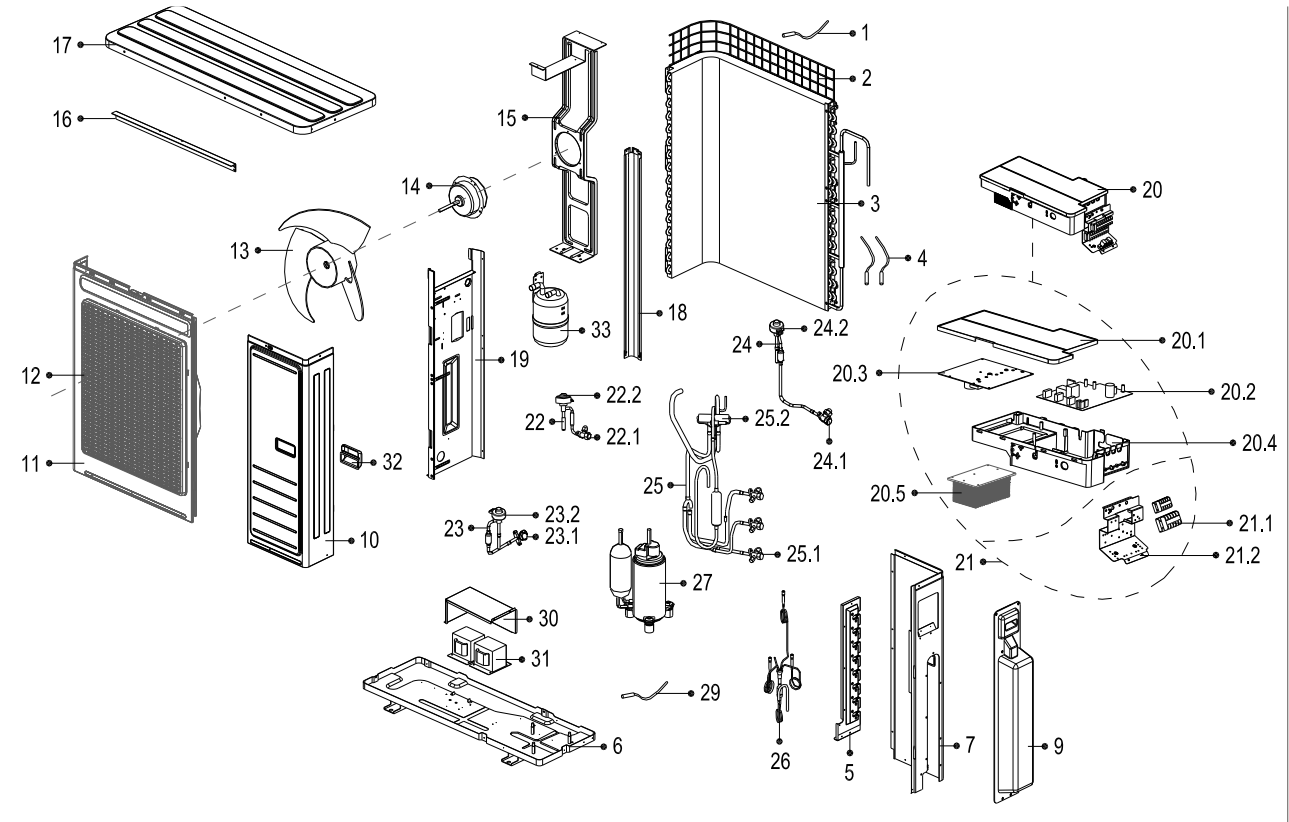

## Spare part list of outdoor unit: AWAU-YCZ327-H11

No.	Part Name	Qty	BOM Code	No.	Part Name	Qty	BOM Code
1	Ambient temperature sensor assembly	1	202301310075	20.5	Radiator	1	202301901173
2	Rear net	1	2011482G0001	21	Terminal board assembly	1	203357190096
3	Condenser assembly	1	201557190037	21.1	Wire joint	2	202301450156
4	Pipe temperature sensor assembly	1	202301300422	21.2	Terminal board	1	201257190120
4	Pipe temperature sensor assembly	1	202301300111	22	Liquid valve assembly	1	201657190352
5	Valve plate	1	201257190111	22.1	Liquid valve	1	201600740091
6	Chassis assembly	1	201257190085	22.2	Electronic expansion valve assembly	1	201601300554
7	Rear right clapboard assembly	1	201257190095	23	Liquid valve assembly	1	201657390002
9	Water collector	1	201157390003	23.1	Liquid valve	1	201600740091
10	Front right clapboard assembly	1	201248200082	23.2	Electronic expansion valve assembly	1	201601300554
11	Front panel	1	201248200103	24	Liquid valve assembly	1	201657390000
12	Air outlet grille	1	2011482A0001	24.1	Liquid valve	1	201600740091
	Round sticker of air outlet grille	1	2011374A0005	24.2	Electronic expansion valve assembly	1	201601300554
13	Axial flow fan	1	201100300527	25	4-ways valve assembly	1	201657190430
14	Brushless DC Motor	1	202400300047	25.1	Gas valve	3	201600720091
15	Supporter assembly of fan motor	1	201257190071	25.2	4-ways valve	1	201600600119
16	Rear supporter	1	201248200095	26	Capillary assembly	1	201657190429
17	Top cover assembly	1	201248300309	27	Compressor	1	201400601740
18	Left supporter	1	201248400036	29	Discharge temperature sensor assembly	1	202448200000
19	Partition board assembly	1	201257190115	30	Cover of inductance	1	201248390003
20	Electronic control box assembly	1	203357190095	31	Reactor	1	202301000950
20.1	Cover of electronic control box	1	201157190011	31	Reactor	1	202301000943
20.2	Outdoor main control board assembly	1	201357190096	32	Handle	2	201148700009
20.3	Inverter control board assembly	1	201357190085	33	Accumulator cylinder	1	201601000620
20.4	Electronic installing box	1	201157190010				

Exploded View of outdoor unit: AWAU-YCZ430-H11

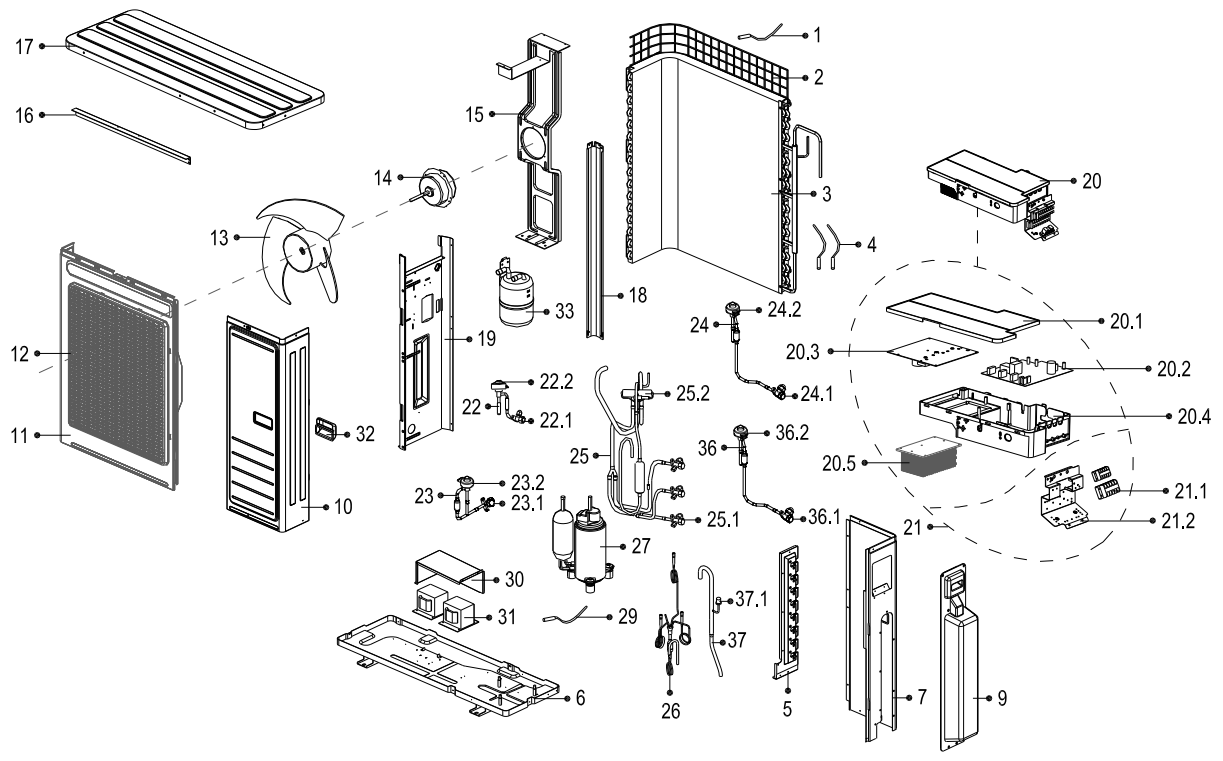



## Spare part list of outdoor unit: AWAU-YCZ430-H11

No.	Part Name	Qty	BOM Code	No.	Part Name	Qty	BOM Code
1	Ambient temperature sensor assembly	1	202301310069	21.2	Terminal board	1	201257190120
2	Rear net	1	2011482G0001	22	Liquid valve assembly	1	201657190352
3	Condenser assembly	1	201557190037	22.1	Liquid valve	1	201600740091
4	Pipe temperature sensor assembly	1	202301300421	22.2	Electronic expansion valve assembly	1	201601300554
4	Pipe temperature sensor assembly	1	202301300111	23	Liquid valve assembly	1	201657390002
5	Valve plate	1	201257190111	23.1	Liquid valve	1	201600740091
6	Chassis assembly	1	201257190085	23.2	Electronic expansion valve assembly	1	201601300554
7	Rear right clapboard assembly	1	201257190095	24	Liquid valve assembly	1	201657390000
9	Water collector	1	201157390003	24.1	Liquid valve	1	201600740091
10	Front right clapboard assembly	1	201248200082	24.2	Electronic expansion valve assembly	1	201601300554
11	Front panel	1	201248200103	25	4-ways valve assembly	1	201657190356
12	Air outlet grille	1	2011482A0001	25.1	Gas valve	4	201600720091
	Round sticker of air outlet grille	1	2011374A0005	25.2	4-ways valve	1	201600600119
13	Axial flow fan	1	201100300527	26	Capillary assembly	1	201657390066
14	Brushless DC Motor	1	202400300047	27	Compressor	1	201400601740
15	Supporter assembly of fan motor	1	201257190071	29	Discharge temperature sensor assembly	1	202448200000
16	Rear supporter	1	201248200095	30	Cover of inductance	1	201248390003
17	Top cover assembly	1	201248300309	31	Reactor	1	202301000950
18	Left supporter	1	201248400036	31	Reactor	1	202301000943
19	Partition board assembly	1	201257190115	32	Handle	2	201148700009
20	Electronic control box assembly	1	203357190102	33	Accumulator cylinder	1	201601000620
20.1	Cover of electronic control box	1	201157190011	36	Liquid valve assembly	1	201657390050
20.2	Outdoor main control board assembly	1	201357190105	36.1	Liquid valve	1	201600740091
20.3	Inverter control board assembly	1	201357190085	36.2	Electronic expansion valve assembly	1	201601300554
20.4	Installation plate of electric parts	1	201157190010	37	Suction pipe assembly	1	201657190354
20.5	Radiator	1	202301901173	37.1	Pressure switch	1	202301820021
21	Terminal board assembly	1	203357190086	21.2	Terminal board	1	201257190120
21.1	Wire joint	1	202301450157	22	Liquid valve assembly	1	201657190352
21.1	Wire joint	1	202301450156				

Exploded View of outdoor unit: AWAU-YCZ536-H11

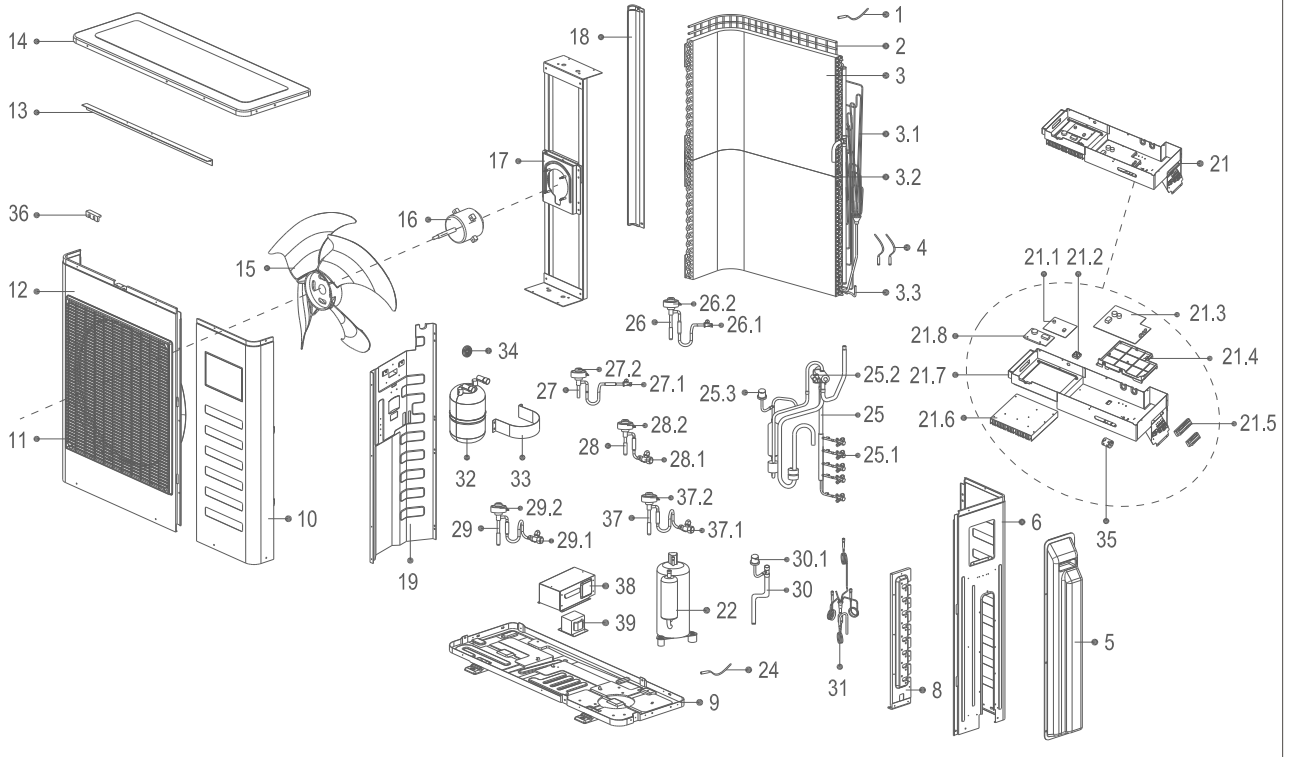

## Spare part list of outdoor unit: AWAU-YCZ536-H11

No.	Part Name	Qty	BOM Code	No.	Part Name	Qty	BOM Code
1	Rear net	1	2011487G0001	21.7	Electronic installing box assembly	1	201257190055
2	Ambient temperature sensor assembly	1	202301310075	21.8	Active PFC Module Subassembly	1	201319901145
3	Condenser assembly	1	201557190043	22	Compressor	1	201401500220
3.1	Input pipe assembly	1	201657290044	24	Discharge temperature sensor assembly	1	202448200000
3.2	Condenser	1	201557190044	25	4-Ways valve assembly	1	201657190376
3.2	Condenser	1	201557190045	25.1	Gas valve	5	201600720091
3.3	Output pipe	1	201657290037	25.2	4-Ways valve	1	201600600124
4	Pipe temperature sensor assembly	1	202301300496	25.3	Pressure switch	1	202301820042
4	Pipe temperature sensor assembly	1	202301300111	26	liquid valve assembly	1	201657290018
5	Big handle	1	201157190005	26.1	Liquid valve	1	201600740091
6	Rear right clapboard assembly	1	201257190091	26.2	Electronic expansion valve assembly	1	201601300554
8	Valve plate	1	201257190107	27	liquid valve assembly	1	201657290020
9	Chassis assembly	1	201275590093	27.1	Liquid valve	1	201600740091
10	Front right clapboard assembly	1	201248700056	27.2	Electronic expansion valve assembly	1	201601300554
11	Air outlet grille	1	2011487A0003	28	liquid valve assembly	1	201657290021
	Round sticker of air outlet grille	1	2011374A0005	28.1	Liquid valve	1	201600740091
12	Front panel	1	201248700072	28.2	Electronic expansion valve assembly	1	201601300554
13	Rear supporter	1	2012487G0011	29	liquid valve assembly	1	201657190373
14	Top cover assembly	1	201257190096	29.1	Liquid valve	1	201600740091
15	Axial flow fan	1	201100320624	29.2	Electronic expansion valve assembly	1	201601300554
16	Brushless DC Motor	1	202400300051	30	Suction pipe assembly	1	201657290026
17	Supporter assembly of fan motor	1	201275590219	30.1	Pressure switch	1	202301820021
18	Left supporter	1	201248700262	31	Capillary assembly	1	201657190362
19	Partition board assembly	1	201257290010	32	Accumulator cylinder	1	201601000074
21	Electronic control box assembly	1	203357190105	33	Fix clamp of segregator	1	201245000901
21.1	Inverter control board assembly	1	201357190031	34	PFC Inductor	1	202301000523
21.2	Rectifier bridge	1	202300500328	35	Magnetic Loop	1	202301000020
21.3	Outdoor main control board assembly	1	201357190113	37	liquid valve assembly	1	201657190371
21.4	Installation plate of electric parts	1	201157190004	37.1	Liquid valve	1	201600740091
21.5	Wire joint	1	202301450122	37.2	Electronic expansion valve assembly	1	201601300554
21.5	Wire joint	2	202301450157	38	Cover of inductance	1	201248090001
21.6	Radiator	1	202301901085	39	Reactor	1	202301000943

# Part 4

## Installation

1.Wrench torque sheet for installation .....	75
2.Connecting the cables .....	75
3.Pipe length and the elevation .....	75
4 Installation for the first time .....	77
5 Adding the refrigerant after running the system for many years .....	80
6 Re-installation while the indoor unit need to be repaired .....	81
7 Re-installation while the outdoor unit need to be repaired .....	83

## 1. Wrench torque sheet for installation

Outside diameter	Torque	Additional tightening torque
mm	N.cm	N.cm
Φ6.35	1500(153kgf.cm)	1600(163kgf.cm)
Φ9.52	2500(255kgf.cm)	2600(265kgf.cm)
Φ12.7	3500(357kgf.cm)	3600(367kgf.cm)

## 2. Connecting the cables

The power cord of connect should be selected according to the following specifications sheet.

Rated current of appliance	Nominal cross-sectional area (mm <sup>2</sup> )
>3 and ≤6	0.75
>6 and ≤10	1
>10 and ≤16	1.5
>16 and ≤25	2.5

The cable size and the current of the fuse or switch are determined by the maximum current indicated on the nameplate which located on the side panel of the unit. Please refer to the nameplate before selecting the cable, fuse and switch.

## 3. Pipe length and the elevation

### Maximum piping length and height difference

		1 drive 2	1 drive 3	1 drive 4	1 drive 5
Max. length for all rooms (m)		30	45	60	75
Max. length for one IU (m)		20	25	30	30
Max. height difference between IU and OU (m)	OU higher than IU	10	10	10	10
	OU lower than IU	15	15	15	15
Max. height difference between IUs (m)		10	10	10	10

### Additional refrigerant charge

	1 drive 2	1 drive 3	1 drive 4	1 drive 5
Chargeless pipe length (m)	10	15	20	25
Additional refrigerant charge (g)	15 x (length for all rooms - 10)	15 x (length for all rooms - 15)	15 x (length for all rooms - 20)	15 x (length for all rooms - 25)

### Caution:

- Refrigerant pipe diameter is different according to indoor unit to be connected. When using the extension pipe, refer to the tables below.
- When refrigerant pipe diameter is different from that of outdoor unit union (for 18K indoor unit), additional transfer connector needs to be used on outdoor unit union.

Indoor unit			Extension pipe diameter (mm/inch)	
Model	Pipe diameter (mm/inch)			
7K9K12K	Liquid	6.35(1/4)	Liquid	6.35(1/4)
	Gas	9.52(3/8)	Gas	9.52(3/8)
18K	Liquid	6.35(1/4)	Liquid	6.35(1/4)
	Gas	12.7(1/2)	Gas	12.7(1/2)
Outdoor unit union diameter (mm/inch)				
Indoor unit A/B/C/D			Liquid	6.35(1/4)
			Gas	9.52(3/8)

## 4. Installation for the first time

Air and moisture in the refrigerant system have undesirable effects as below:

- Pressure in the system rises.
- Operating current rises.
- Cooling or heating efficiency drops.
- Moisture in the refrigerant circuit may freeze and block capillary tubing.
- Water may lead to corrosion of parts in the refrigerant system.

Therefore, the indoor units and the pipes between indoor and outdoor units must be leak tested and evacuated to remove gas and moisture from the system.

Gas leak check (Soap water method):

Apply soap water or a liquid neutral detergent on the indoor unit connections or outdoor unit connections by a soft brush to check for leakage of the connecting points of the piping. If bubbles come out, the pipes have leakage.

### 4.1. Air purging with vacuum pump

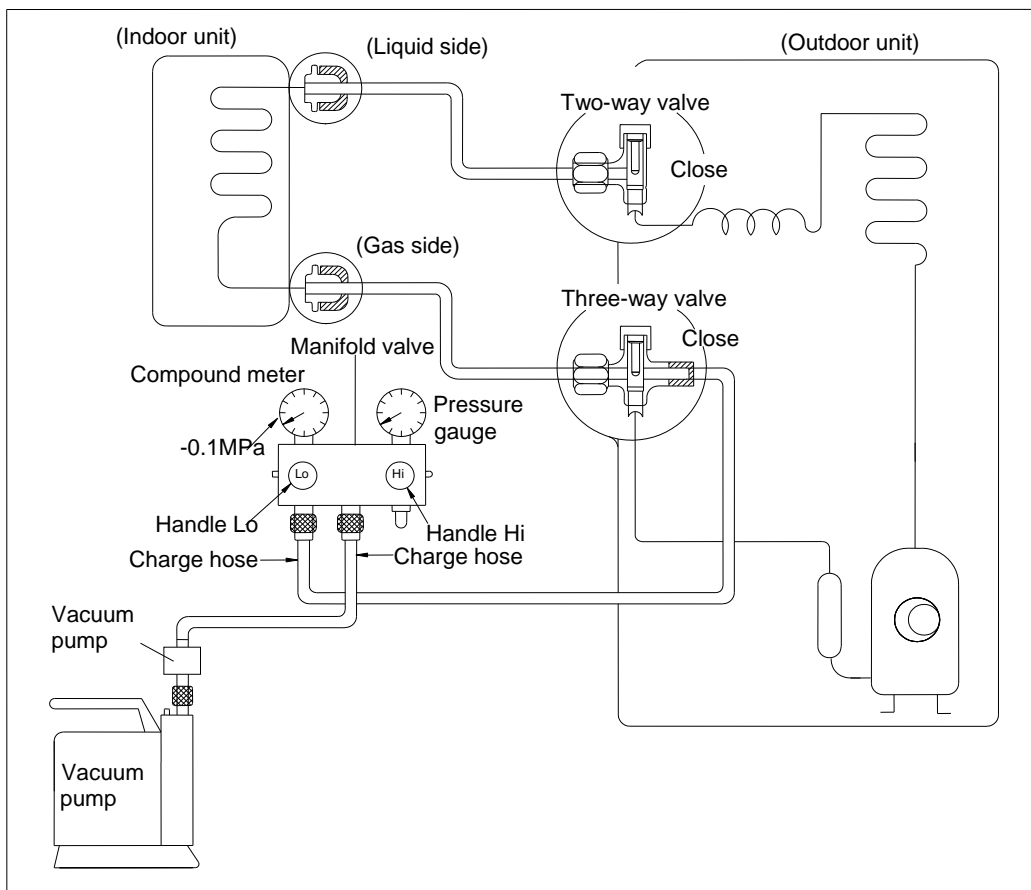

- 1) Completely tighten the flare nuts of the indoor and outdoor units, confirm that both the 2-way and 3-way valves are set to the closed position.
- 2) Connect the charge hose with the push pin of handle lo to the 3-way valves gas service port..
- 3) Connect the charge hose of handle hi connection to the vacuum pump.
- 4) Fully open the handle Lo of the manifold valve.
- 5) Operate the vacuum pump to evacuate.
- 6) Make evacuation for 30 minutes and check whether the compound meter indicates -0.1Mpa. If the meter does not indicate -0.1Mpa after pumping 30 minutes, it should be pumped 20 minutes more. If the pressure can't achieve -0.1Mpa after pumping 50 minutes, please check if there are some leakage points. Fully close the handle Lo valve of the manifold valve and stop the operation of the vacuum pump. Confirm that the gauge needle does not move (approximately 5 minutes after turning off the vacuum pump).

- 7) Turn the flare nut of the 3-way valves about 45° counterclockwise for 6 or 7 seconds after the gas coming out, then tighten the flare nut again. Make sure the pressure display in the pressure indicator is a little higher than the atmosphere pressure. Then remove the charge hose from the 3 way valve.
- 8) Fully open the 2 way valve and 3 way valve and securely tighten the cap of the 3 way valve.

#### 4.2. Air purging by refrigerant

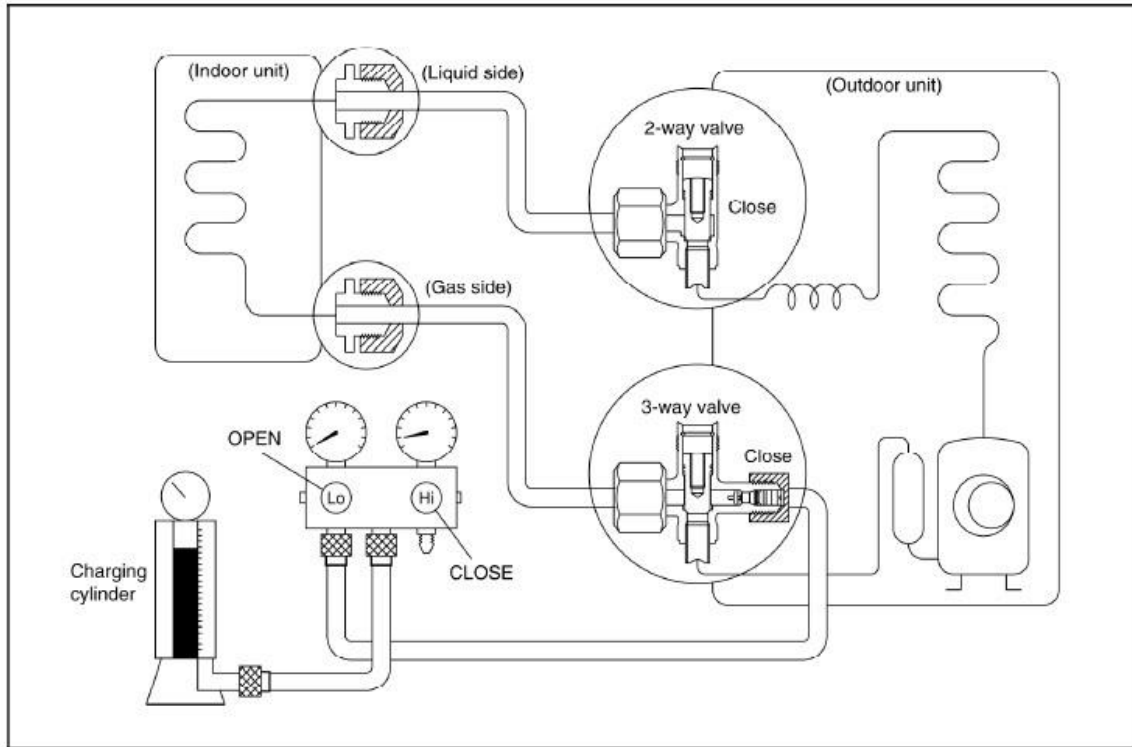

##### Procedure:

- 1). Confirm that both the 2-way and 3-way valves are set to the closed position.
- 2). Connect the charge set and a charging cylinder to the service port of the 3-way valve.
- 3). Air purging.  
Open the valves on the charging cylinder and the charge set. Purge the air by loosening the flare nut on the 2-way valve approximately 45° for 3 seconds then closing it for 1 minute; repeat 3 times.  
After purging the air, use a torque wrench to tighten the flare nut on the 2-way valve.
- 4). Check the gas leakage.  
Check the flare connections for gas leakage.
- 5). Discharge the refrigerant.  
Close the valve on the charging cylinder and discharge the refrigerant by loosening the flare nut on the 2-way valve approximately 45° until the gauge indicates 0.3 to 0.5 Mpa.
- 6). Disconnect the charge set and the charging cylinder, and set the 2-way and 3-way valves to the open position.  
Be sure to use a hexagonal wrench to operate the valve stems.



7). Mount the valve stems nuts and the service port cap.

Be sure to use a torque wrench to tighten the service port cap to a torque 18N·m.

Be sure to check the gas leakage.

#### 4.3. Adding the refrigerant if the pipe length >5m

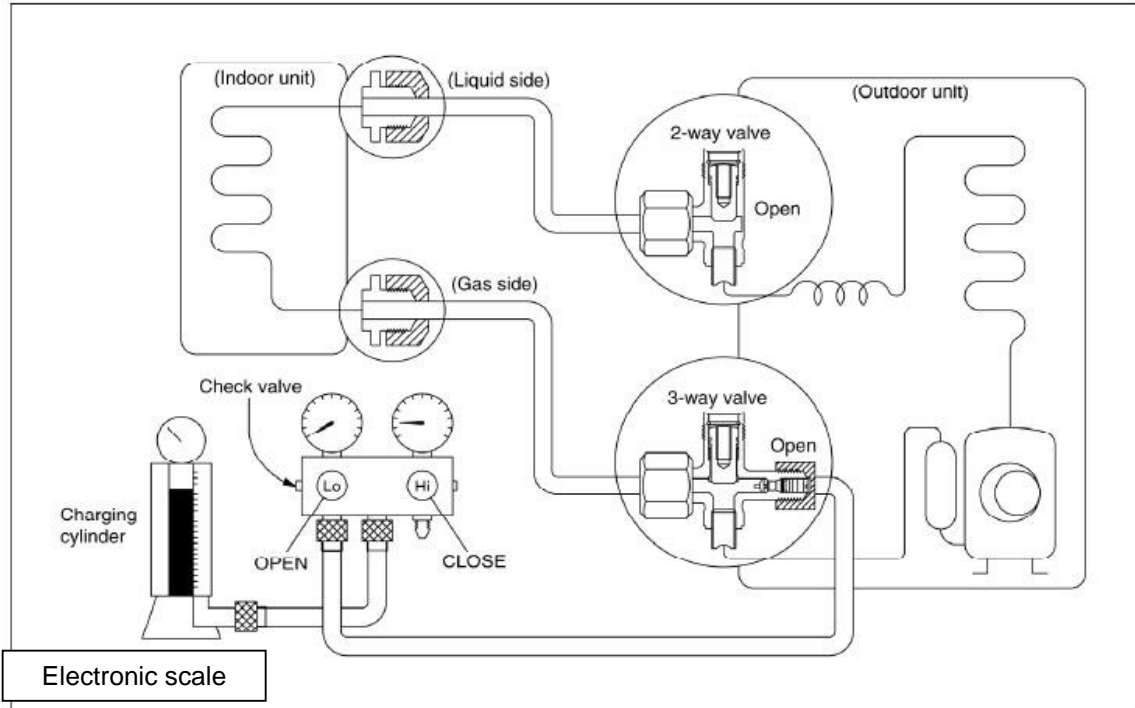

##### Procedure:

- 1). Connect the charge hose to the charging cylinder, open the 2-way valve and the 3-way valve. Connect the charge hose which you disconnected from the vacuum pump to the valve at the bottom of the cylinder. If the refrigerant is R410A, make the cylinder bottom up to ensure the liquid charge.
- 2). Purge the air from the charge hose.  
Open the valve at the bottom of the cylinder and press the check valve on the charge set to purge the air (be careful of the liquid refrigerant).
- 3) Put the charging cylinder onto the electronic scale and record the weight.
- 4) Operate the air conditioner at the cooling mode.
- 5) Open the valves (Low side) on the charge set and charge the system with liquid refrigerant.
- 6).When the electronic scale displays the proper weight (refer to the table), disconnect the charge hose from the 3-way valve's service port immediately and turn off the air conditioner before disconnecting the hose.
- 7). Mount the valve stem caps and the service port  
Use torque wrench to tighten the service port cap to a torque of 18N·m.  
Be sure to check for gas leakage.

## 5. Adding the refrigerant after running the system for many years

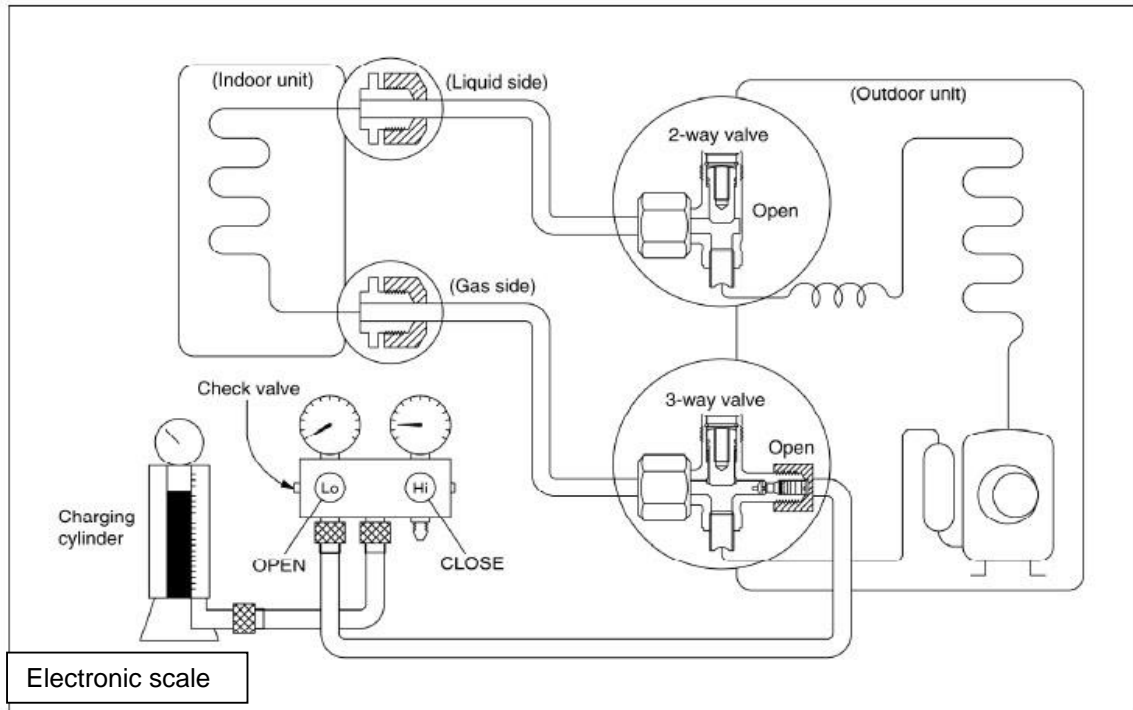

### Procedure:

- 1). Connect the charge hose to the 3-way service port, open the 2-way valve and the 3-way valve. Connect the charge hose to the valve at the bottom of the cylinder. If the refrigerant is R410A, make the cylinder bottom up to ensure liquid charge.
- 2). Purge the air from the charge hose.  
Open the valve at the bottom of the cylinder and press the check valve on the charge set to purge the air (be careful of the liquid refrigerant).
- 3) Put the charging cylinder onto the electronic scale and record the weight.
- 4) Operate the air conditioner at the cooling mode.
- 5) Open the valves (Low side) on the charge set and charge the system with liquid refrigerant.
- 6).When the electronic scale displays the proper weight (refer to the gauge and the pressure of the low side), disconnect the charge hose from the 3-way valve's service port immediately and turn off the air conditioner before disconnecting the hose.
- 7). Mount the valve stem caps and the service port  
Use torque wrench to tighten the service port cap to a torque of 18N.m.  
Be sure to check for gas leakage.

## 6. Re-installation while the indoor unit need to be repaired

### 6.1. Collecting the refrigerant into the outdoor unit

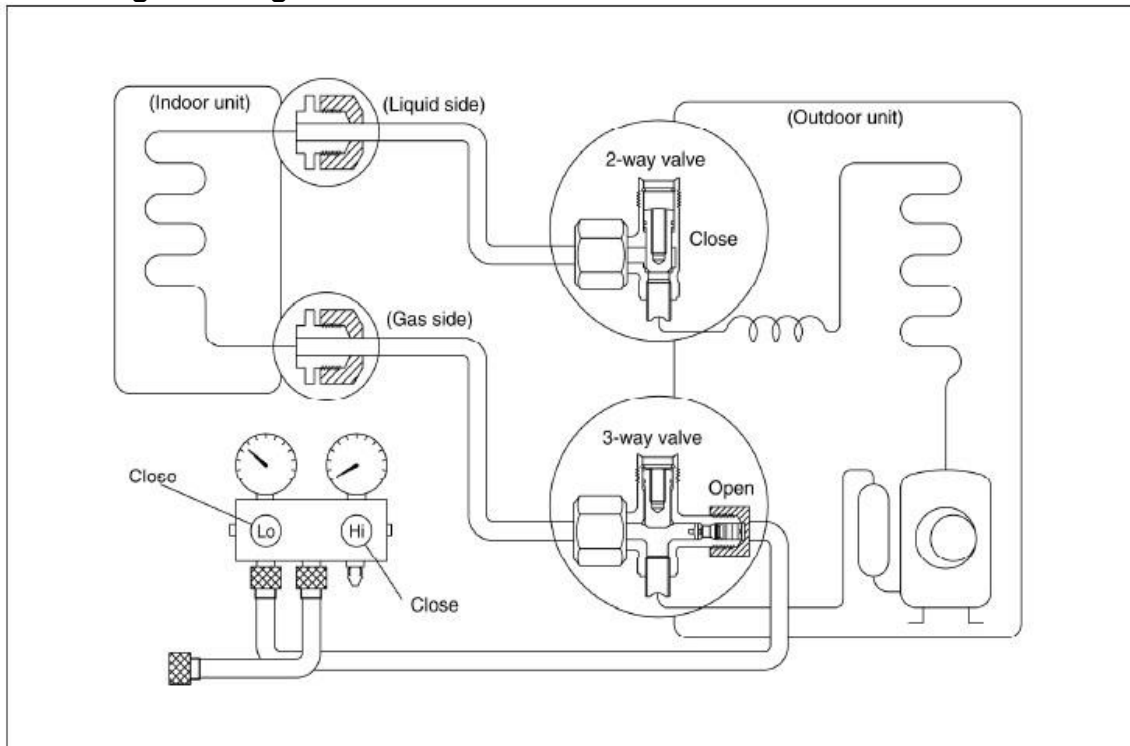

#### Procedure

- 1). Confirm that both the 2-way and 3-way valves are set to the opened position

Remove the valve stem caps and confirm that the valve stems are in the opened position.

Be sure to use a hexagonal wrench to operate the valve stems.

- 2). Connect the charge hose with the push pin of handle lo to the 3-way valves gas service port.

- 3). Air purging of the charge hose.

Open the handle Lo valve of the manifold valve slightly to purge air from the charge hose for 5 seconds and then close it quickly.

- 4). Set the 2-way valve to the close position.

- 5). Operate the air conditioner at the cooling cycle and stop it when the gauge indicates 0.1MPa.

- 6). Set the 3-way valve to the closed position immediately

Do this quickly so that the gauge ends up indicating 0.3 to 0.5Mpa.

Disconnect the charge set, and tighten the 2-way and 3-way valve's stem nuts.

Use a torque wrench to tighten the 3-way valves service port cap to a torque of 1.8 kgf.m.

Be sure to check for gas leakage.

## 6.2. Air purging by the refrigerant

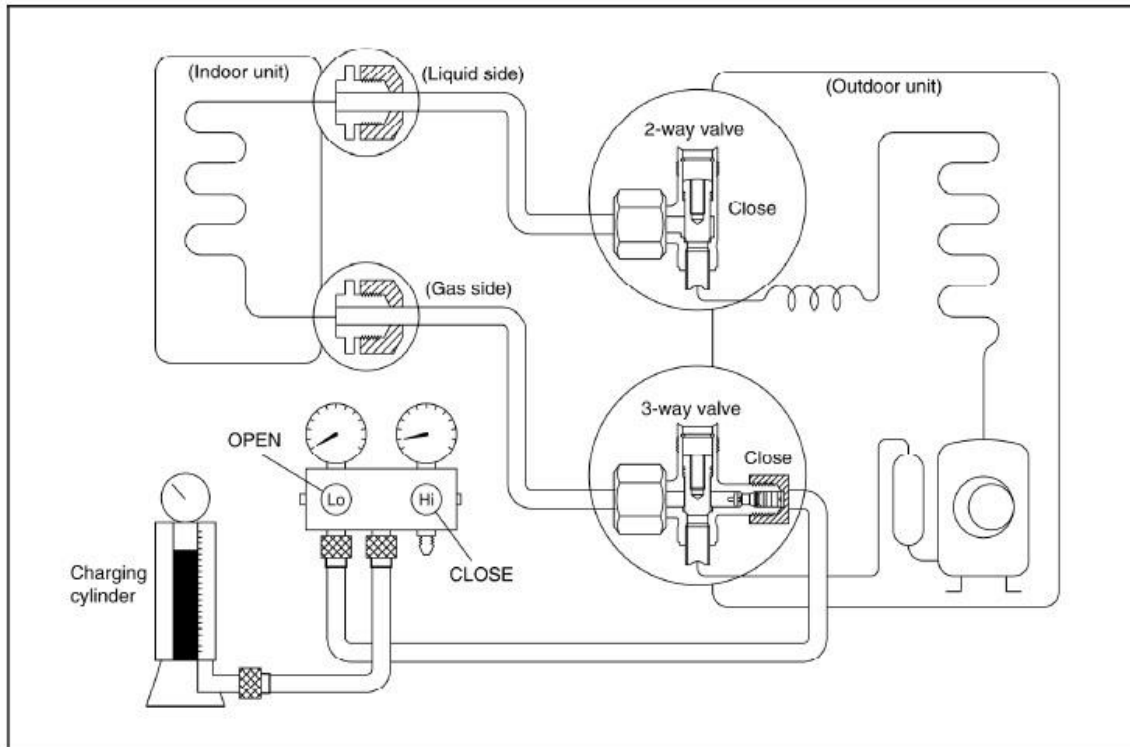

### Procedure:

- 1). Confirm that both the 2-way and 3-way valves are set to the closed position.
- 2). Connect the charge set and a charging cylinder to the service port of the 3-way valve  
Leave the valve on the charging cylinder closed.
- 3). Air purging.  
Open the valves on the charging cylinder and the charge set. Purge the air by loosening the flare nut on the 2-way valve approximately 45° for 3 seconds then closing it for 1 minute; repeat 3 times.  
After purging the air, use a torque wrench to tighten the flare nut on the 2-way valve.
- 4). Check the gas leakage  
Check the flare connections for gas leakage.
- 5). Discharge the refrigerant.  
Close the valve on the charging cylinder and discharge the refrigerant by loosening the flare nut on the 2-way valve approximately 45° until the gauge indicates 0.3 to 0.5 Mpa.
- 6). Disconnect the charge set and the charging cylinder, and set the 2-way and 3-way valves to the open position  
Be sure to use a hexagonal wrench to operate the valve stems.
- 7). Mount the valve stems nuts and the service port cap  
Be sure to use a torque wrench to tighten the service port cap to a torque 18N.m.

Be sure to check the gas leakage.

## 7. Re-installation while the outdoor unit need to be repaired

### 7.1. Evacuation for the whole system

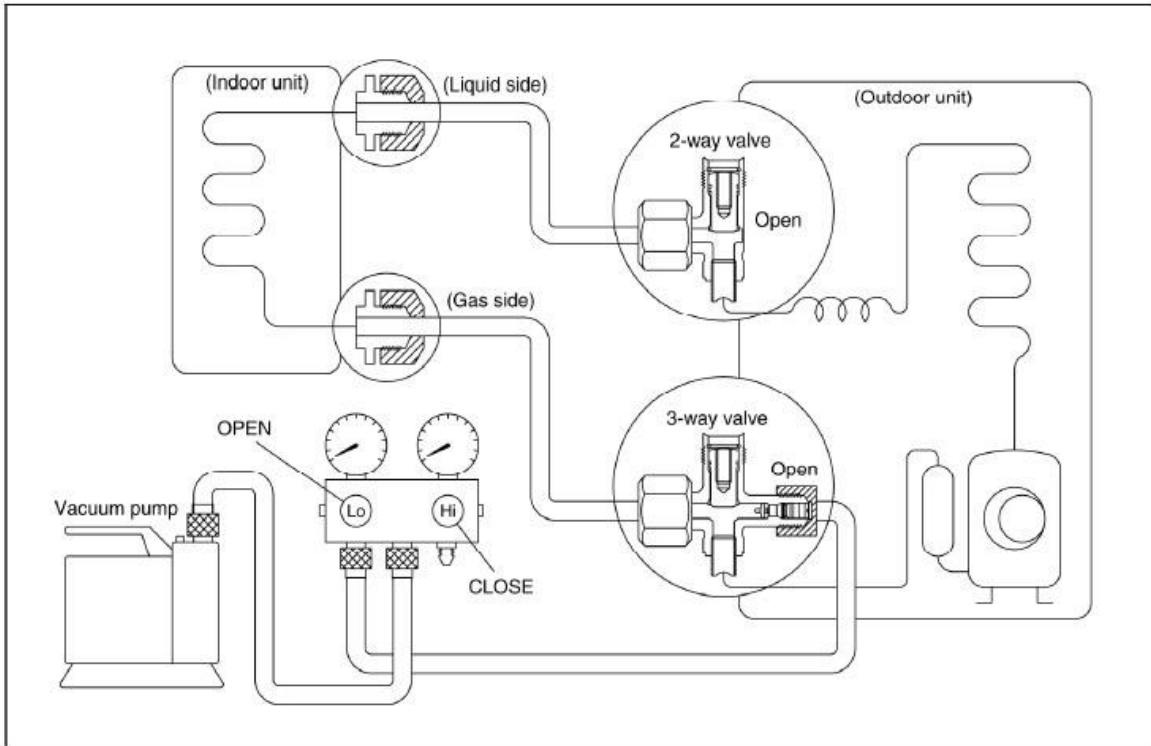

#### Procedure:

- 1). Confirm that both the 2-way and 3-way valves are set to the opened position.
- 2). Connect the vacuum pump to 3-way valve's service port.
- 3). Evacuation for approximately one hour. Confirm that the compound meter indicates -0.1Mpa.
- 4). Close the valve (Low side) on the charge set, turn off the vacuum pump, and confirm that the gauge needle does not move (approximately 5 minutes after turning off the vacuum pump).
- 5). Disconnect the charge hose from the vacuum pump.

## 7.2. Refrigerant charging

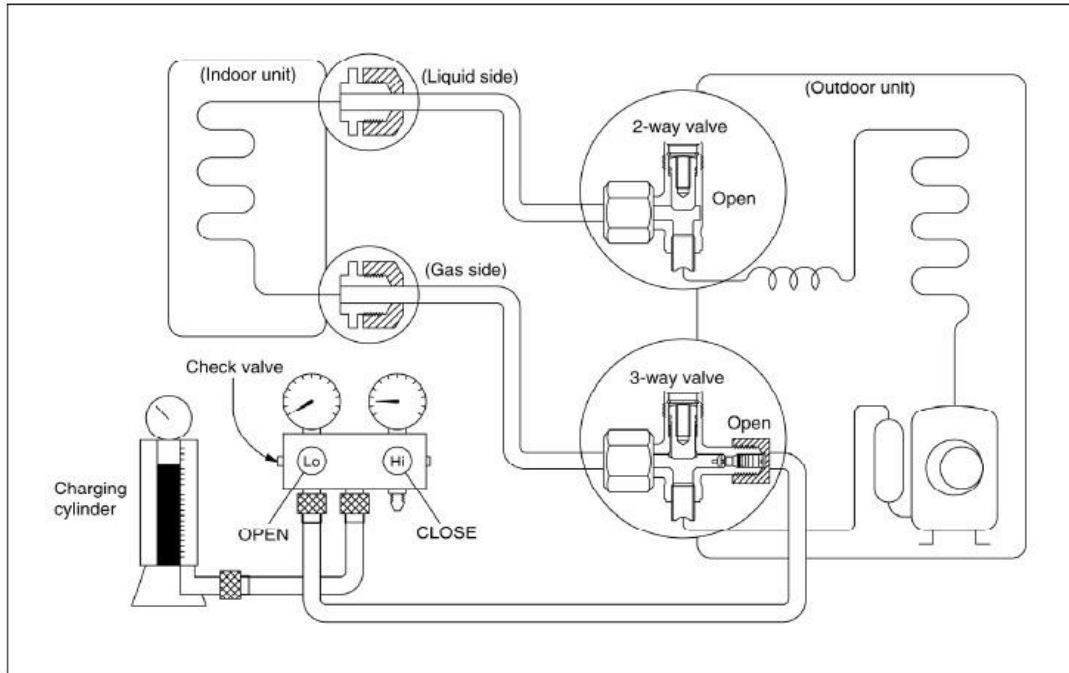

### Procedure:

- 1). Connect the charge hose to the charging cylinder, open the 2-way valve and the 3-way valve  
Connect the charge hose which you disconnected from the vacuum pump to the valve at the bottom of the cylinder. If the refrigerant is R410A, make the cylinder bottom up to ensure liquid charge.
- 2). Purge the air from the charge hose  
Open the valve at the bottom of the cylinder and press the check valve on the charge set to purge the air (be careful of the liquid refrigerant).
- 3) Put the charging cylinder onto the electronic scale and record the weight.
- 4). Open the valves (Low side) on the charge set and charge the system with liquid refrigerant  
If the system cannot be charge with the specified amount of refrigerant, or can be charged with a little at a time (approximately 150g each time) , operating the air conditioner in the cooling cycle; however, one time is not sufficient, wait approximately 1 minute and then repeat the procedure.
- 5).When the electronic scale displays the proper weight, disconnect the charge hose from the 3-way valve's service port immediately  
If the system has been charged with liquid refrigerant while operating the air conditioner, turn off the air conditioner before disconnecting the hose.
- 6). Mounted the valve stem caps and the service port  
Use torque wrench to tighten the service port cap to a torque of 18N.m.  
Be sure to check for gas leakage

# **Part 5**

## **Electrical Control System**

1. Electrical Control Function.....	86
2. Troubleshooting.....	100

## 1. Electrical Control Function

### 1.1 Definition

- T1: Room Air Thermistor (RAT)  
 T2: Indoor Coil Thermistor (ICT)  
 T2B: Indoor Return Gas Thermistor (RGT)  
 T3: Outdoor Coil Thermistor (OCT)  
 T4: Outdoor Air Thermistor (OAT)  
 T5: Compressor Discharge Thermistor (CTT)

### 1.2 Main Protection

#### 1.2.1 Three minutes delay at restart for compressor.

#### 1.2.2 Temperature protection of compressor discharge

When the compressor discharge temp. is getting higher, the running frequency will be limited as below rules:

---If  $102^{\circ}\text{C} < T5 < 115^{\circ}\text{C}$ , decrease the frequency to the lower level every 2 minutes till to F1.

---If  $T5 > 115^{\circ}\text{C}$  for 10 seconds, the compressor will stop and restart till  $T5 < 90^{\circ}\text{C}$ .

#### 1.2.3 Sensor protection at open circuit and breaking disconnection.

#### 1.2.4 Indoor fan delayed open function

When the unit starts up, the louver will be active immediately and the indoor fan will open 10s later.

If the unit runs in heating mode, the indoor fan will be also controlled by anti-cold wind function.

#### 1.2.5 Fan speed is out of control(Excluding AWSI-HKD009-N11)

When indoor fan speed keeps too low for certain time, the unit will stop and the LED will display the failure.

#### 1.2.6 Zero crossing detection error protection(only for AWSI-HKD009-N11)

If AC detects time interval is not correct for continuous 240s, the unit will stop and the LED will display the failure. The correct zero crossing signal time interval should be between 6-13ms.

#### 1.2.7 Inverter module protection

The Inverter module has a protection function about current, voltage and temperature. If these protections happen, the corresponding code will display on indoor unit and the unit will stop working.

#### 1.2.8 Compressor current limit protection

If the compressor current exceeds the current limit value for 10 seconds, the compressor frequency will be limited as below table.

##### Cooling mode:

Current frequency (Hz)	Current limit value (A)	Frequency limit
COOL_F16	ICOOLLMT12	Decrease the frequency to COOL_F4 and run at COOL_F4 for 3 minutes.  After that, the frequency will be adjusted according to the capacity demand and rise to the upper level every 3 minutes (When the frequency > COOL_F4 via capacity demand).
COOL_F15	ICOOLLMT11	
COOL_F14	ICOOLLMT10	
COOL_F13	ICOOLLMT9	
COOL_F12	ICOOLLMT8	
COOL_F11	ICOOLLMT7	
COOL_F10	ICOOLLMT6	
COOL_F9	ICOOLLMT5	
COOL_F8	ICOOLLMT4	
COOL_F7	ICOOLLMT3	



COOL_F6	ICOOLLMT2	
COOL_F5	ICOOLLMT1	
<p>If the current frequency is lower than COOL_F4, the frequency will not be limited.          After 10s of the compressor start, if the current&gt;ICOOL, the AC will display the failure for 30 seconds and stop. The AC will restart 3 minutes later.</p>		

**Heating mode:**

Current frequency (Hz)	Current limit value (A)	Frequency limit
HEAT_F16	IHEATLMT12	<p>Decrease the frequency to HEAT_F4 and run at HEAT_F4 for 3 minutes.</p> <p>After that, the frequency will be adjusted according to the capacity demand and rise to the upper level every 3 minutes (When the frequency&gt;Heat_F4 via capacity demand).</p>
HEAT_F15	IHEATLMT11	
HEAT_F14	IHEATLMT10	
HEAT_F13	IHEATLMT9	
HEAT_F12	IHEATLMT8	
HEAT_F11	IHEATLMT7	
HEAT_F10	IHEATLMT6	
HEAT_F9	IHEATLMT5	
HEAT_F8	IHEATLMT4	
HEAT_F7	IHEATLMT3	
HEAT_F6	IHEATLMT2	
HEAT_F5	IHEATLMT1	
<p>If the current frequency is lower than HEAT_F4, the frequency will not be limited.          After 10s of the compressor start, if the current&gt;IHEAT, the AC will display the failure for 30 seconds and stop. The AC will restart 3 minutes later.</p>		

**1.2.9 Indoor / outdoor units communication protection**

If the indoor units cannot receive the feedback signal from the outdoor units for 2 minutes, the AC will stop and display the failure.

**1.2.10 Oil return****Running rules:**

1. If the compressor frequency keeps lower than RET\_OIL\_FREQ1\_ADD for RET\_OIL\_TIME1\_ADD, the AC will rise the frequency to RET\_OIL\_FREQ2\_ADD for RET\_OIL\_TIME2\_ADD and then resume to former frequency.
2. The EXV will keep 300p while the indoor units will keep the current running mode.
3. If the outdoor ambient is higher than TempT4HeatLimit\_ADD during the oil return, the AC quit oil return.

**1.3 Operation Modes and Functions****1.3.1 Fan mode**

- (1) Outdoor fan and compressor stop.
- (2) Temperature setting function is disabled, and no setting temperature is displayed.
- (3) Indoor fan can be set to high/med/low/auto;
- (4) The louver operates same as in cooling mode.
- (5) Auto fan:

For Cassette、Duct

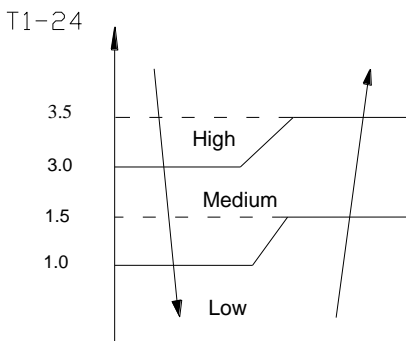

For HKD,HND, Console

T1-24

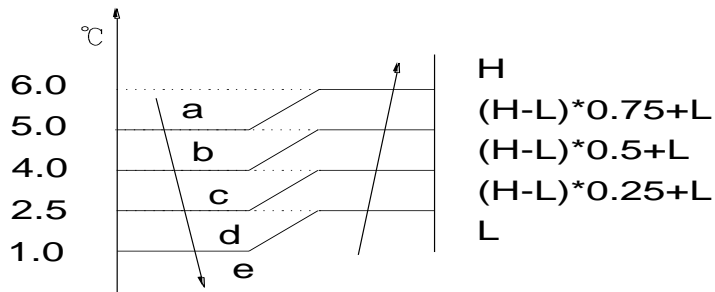

### 1.3.2 Cooling Mode

#### 1.3.2.1 Compressor running rules

The compressor will run at corresponding frequency according to the gross amendatory capacity demand.

Frequency	COOL_F0	COOL_F1	COOL_F2	.....	COOL_F15	COOL_F16
Amendatory capacity demand.	0	1	2	.....	15	16

Meanwhile the maximum running frequency will be adjusted according to the outdoor ambient temp.

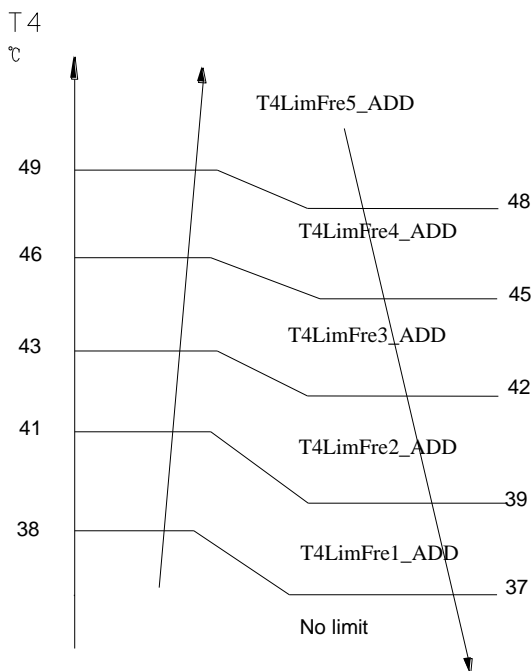

#### 1.3.2.2 Outdoor fan running rules

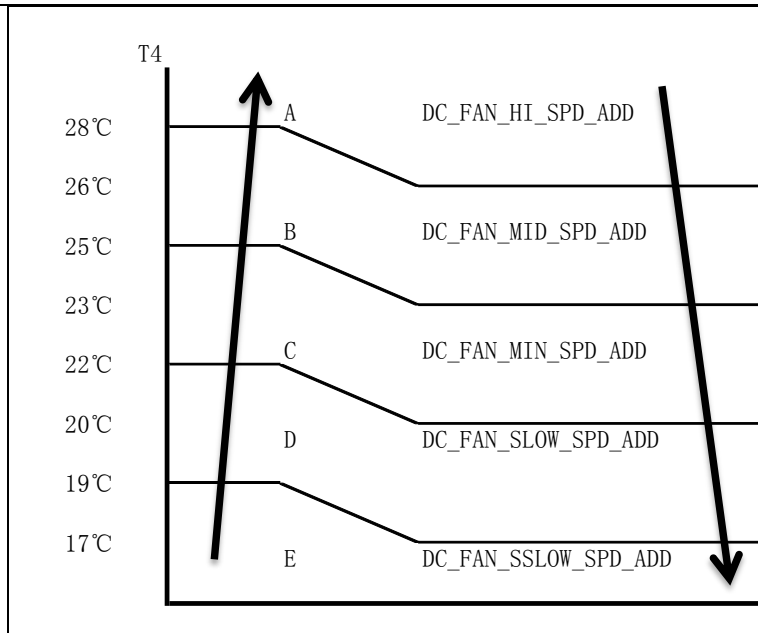

**1.3.2.3 Indoor fan running rules**

For Cassette、A5

In cooling mode, indoor fan runs all the time and the speed can be selected as high, medium, low and auto.

The auto fan:

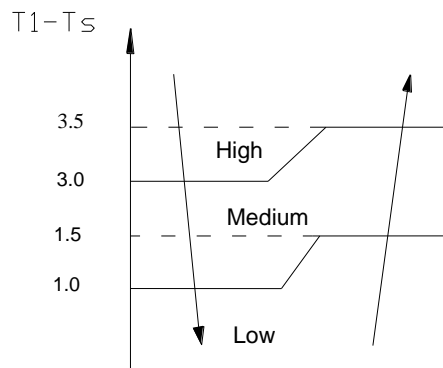

For HKD,HND, Console:

In cooling mode, indoor fan runs all the time and the speed can be selected as high, medium, low and auto.

When the compressor is running, the indoor fan is controlled as below:

Setting Fan speed	T1-Ts		Actual fan speed
H	4.5	A	$H+(H+=H+G)$
	3.0	B	$H (=H)$
	1.5	C	$H- (H=H-G)$
M	4.5	D	$M+(M+=M+Z)$
	3.0	E	$M(M=M)$
	1.5	F	$M-(M-=M-Z)$
L	4.5	G	$L+(L+=L+D)$
	3.0	H	$L(L=L)$
	1.5	I	$L-(L-=L-D)$

The auto fan acts as below rules:

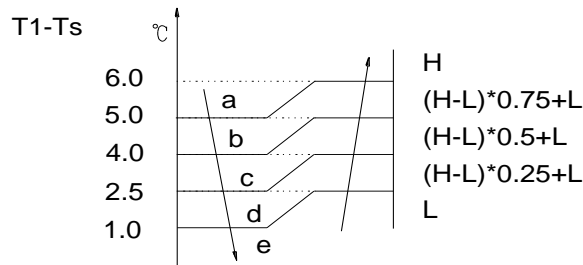

**1.3.2.4 Condenser temperature protection**

When  $T3 > 65^{\circ}\text{C}$  for 3 seconds, the compressor will stop while the indoor fan and outdoor fan will continue.

When  $T3 < 52^{\circ}\text{C}$ , the protection will release and the compressor will restart after 3 minutes.

**1.3.2.5 Evaporator low temperature protection**

When  $T2B < 0^{\circ}\text{C}$  for 250 seconds, the indoor unit has no capacity demand and resume till  $T2B > 10^{\circ}\text{C}$ .

When  $T2 < 4^{\circ}\text{C}$ , the indoor has no capacity demand and resume till  $T2 > 8^{\circ}\text{C}$ .

**1.3.3 Heating Mode**

**1.3.3.1 Compressor running rules**

The compressor will run at corresponding frequency according to the gross amendatory capacity demand.

Frequency	0	HEAT_F1	HEAT_F2	.....	HEAT_F15	HEAT_F16
Amendatory capacity demand.	0	1	2	.....	15	16

**1.3.3.2 Outdoor fan running rules:**

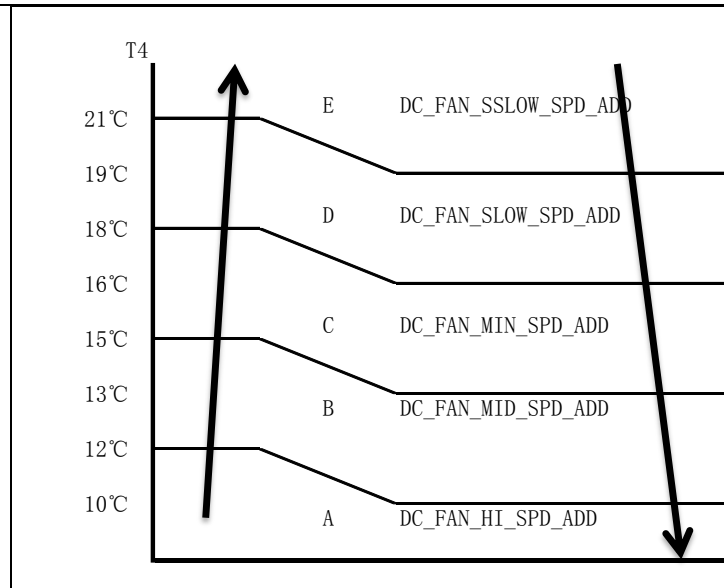

**1.3.3.3 Indoor fan running rules:**

For HKD,HND, Console

In heating mode, indoor fan can be selected as high, medium, low, auto and silent. The anti-cold-wind function has the priority.

When the compressor is running, the indoor fan is controlled as below:

Setting fan speed	T1-Ts	Actual fan speed
H	-1.5	H+ (H=H+G)
	-3.0	H (=H)
	-4.5	H+(H+=H+G)
M	-1.5	M-(M-=M-Z)
	-3.0	M(M=M)
	-4.5	M+(M+=M+Z)
L	-1.5	L-(L-=L-D)
	-3.0	L(L=L)
	-4.5	L+(L+=L+D)

If the compressor stops caused by the room temperature rising, the indoor fan will be forced to run 127 seconds with breeze. During this period, the anti-cold-wind is disabled.

Auto fan action in heating mode:

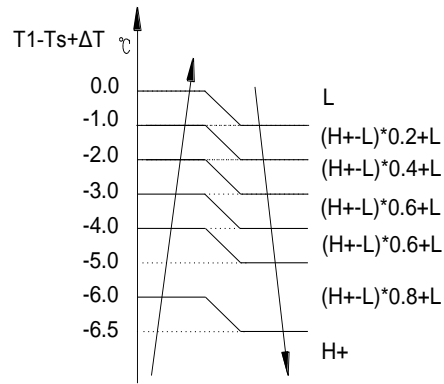

For Cassette & Duct:

When the compressor is on, the indoor fan can be set to high, medium, low and auto. And the anti-cold wind function has the priority.

**Auto fan action:**

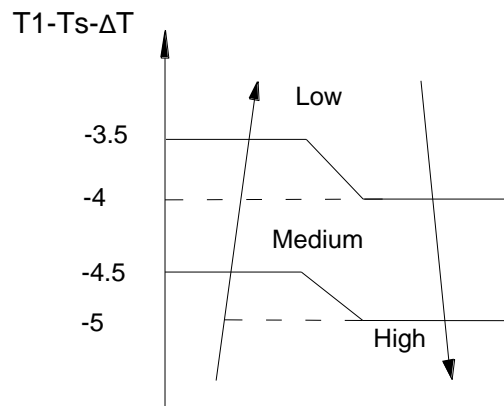

### 1.3.3.4 Prevent Over-Heating

In heating mode, when the indoor unit has no capacity requirement due to indoor room temperature increased, the Indoor fan will run in super breeze. (Anti-cold wind function has the priority)

### 1.3.3.5 Defrosting mode:

#### Condition of defrosting:

If any one of the following items is satisfied, AC will enter the defrosting mode.

After the compressor starts up and keeps running, mark the minimum value of T3 from the 10th minutes to 15th minutes as T30.

- 1) If the compressor cumulate running time is up to 29 minutes and  $T3 < TCDI1$ ,  $T3 + T30SUBT3ONE \leq T30$ .
- 2) If the compressor cumulate running time is up to 35 minutes and  $T3 < TCDI2$ ,  $T3 + T30SUBT3TWO \leq T30$ .
- 3) If the compressor cumulate running time is up to 29 minutes and  $T3 < TCDI3$  for 3 minutes.
- 4) If the compressor cumulate running time is up to 120 minutes and  $T3 < -15^{\circ}\text{C}$ .

#### Condition of ending defrosting:

If any one of the following items is satisfied, the defrosting will finish and the machine will turn to normal heating mode.

- T3 rises to be higher than TCDE1°C.
- T3 keeps to be higher than TCDE2°C for 80 seconds.
- The machine has run for 10 minutes in defrosting mode.

**Defrosting action:**

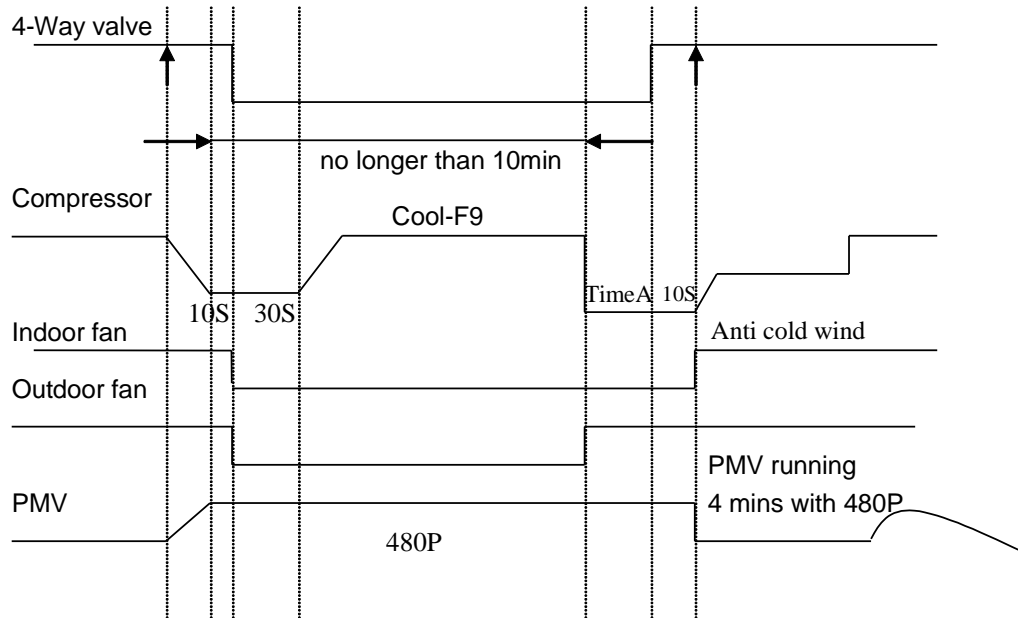

**1.3.3.5 High evaporator coil temp.T2 protection:**

If T2>63°C, the indoor unit has no capacity demand and resume till 48°C.

**1.3.4 Auto-mode**

This mode can be chosen with remote controller and the setting temperature can be changed between 17~30°C.

In auto mode, the machine will choose cooling, heating or fan-only mode according to ΔT (ΔT =T1-Ts).

ΔT=T1-Ts	Running mode
ΔT>1°C	Cooling
-1<ΔT≤1°C	Fan-only
ΔT≤-1°C	Heating

Indoor fan will run at auto fan of the relevant mode.

The louver operates same as in relevant mode.

If the machine switches mode between heating and cooling, the compressor will keep stopping for 15 minutes and then choose mode according to T1-Ts.

If the setting temperature is modified, the machine will choose running function again.

**1.3.5 Drying mode**

HKD,HND(9K,12K)

Indoor fan speed is fixed at breeze and can't be changed. The louver angle is the same as in cooling mode.

---

### Low indoor room temperature protection

All protections are active and the same as that in cooling mode.

For other models:

Indoor fan speed is fixed at breeze and can't be changed. The louver angle is the same as in cooling mode.

### Low indoor room temperature protection

In drying mode, if room temperature is lower than 10°C, the compressor will stop and not resume until room temperature exceeds 12°C.

All protections are active and the same as that in cooling mode.

## 1.3.6 Timer function

1.3.6.1 Timing range is 24 hours.

1.3.6.2 Timer on. The machine will turn on automatically when reaching the setting time.

1.3.6.3 Timer off. The machine will turn off automatically when reaching the setting time.

1.3.6.4 Timer on/off. The machine will turn on automatically when reaching the setting "on" time, and then turn off automatically when reaching the setting "off" time.

1.3.6.5 Timer off/on. The machine will turn off automatically when reaching the setting "off" time, and then turn on automatically when reaching the setting "on" time.

1.3.6.6 The timer function will not change the AC current operation mode. Suppose AC is off now, it will not start up firstly after setting the "timer off" function. And when reaching the setting time, the timer LED will be off and the AC running mode has not been changed.

1.3.6.7 The setting time is relative time.

## 1.3.7 Economy function

1.3.7.1 The sleep function is available in cooling, heating or auto mode.

1.3.7.2. Operation process in sleep mode is as follow:

When cooling, the setting temperature rises 1°C (be lower than 30°C) every one hour, 2 hours later the setting temperature stops rising and the indoor fan is fixed at low speed.

When heating, the setting temperature decreases 1°C (be higher than 17°C) every one hour, 2 hours later the setting temperature stops rising and indoor fan is fixed at low speed. (Anti-cold wind function has the priority).

1.3.7.3 Operation time in sleep mode is 7 hours. After 7 hours the AC quits this mode, the unit will turn off.

1.3.7.4 Timer setting is available

## 1.3.8 Auto-Restart function

The indoor unit is equipped with auto-restart function, which is carried out through an auto-restart module. In case of a sudden power failure, the module memorizes the setting conditions before the power failure. The unit will resume the previous operation setting (not including Swing function) automatically after 3 minutes when power returns.



### 1.3.10 Forced operation function

1.3.10.1 Enter forced operation function:

Press the touch button continually, the AC will run as below sequence:

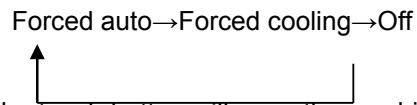

When the machine is off, pressing the touch button will carry the machine to forced auto mode, after this, if pressing the button once again, the machine will turn into forced cooling mode.

In forced cooling mode, pressing touch button will turn off the machine.

1.3.10.2 In forced operation mode, all general protections and remote control are available.

1.3.10.3 Operation rules:

Forced cooling mode:

The compressor runs at F2 frequency and indoor fan runs as breeze. After running for 30 minutes. the machine will turn to auto mode as 24°C setting temperature.

Forced auto mode:

The action of forced auto mode is the same as normal auto mode with 24°C setting temperature.

1.3.10.4 When there's indoor unit running in forced cooling, it is the master forced cooling unit. Other indoor units will run at forced cooling mode too and they will be the slave forced cooling units. The slave forced cooling units cannot quit forced cooling mode until the master forced cooling unit quit, and turn to cooling mode in low speed with 24°C setting temperature.

1.3.10.5 The slave forced cooling units will not be controlled by other signals.

### 1.3.11 Drain pump control (For Cassette)

Adopt the water-level switch to control the action of drain pump.

Main action under different condition : ( every 5 seconds the system will check the water level one time)

1. When the A/C operates with cooling (including auto cooling) and forced cooling mode, the pump will start running immediately and continuously, till stop cooling.
2. Once the water level increase and up to the control point, LED will alarm and the drain pump open and continue checking the water level. If the water level fall down and LED disarmed (drain pump delay close 1 minute) and operate with the last mode. Otherwise the entire system stop operating ( including the pump) and LED remain alarming after 3 minutes.

### 1.3.12 Follow me

- 1) If the indoor PCB receives the signal which results from pressing the FOLLOW ME button on remote controller, the buzzer will emit a sound and this indicates the follow me function is initiated. But when the indoor PCB receives signal which sent from remote controller every 3 minutes, the buzzer will not respond. When the unit is running with follow-me function, the PCB will control the unit according to the temperature from follow-me signal, and the temperature collection function of room temperature sensor will be shielded.
- 2) When the follow-me function is available, the PCB will not respond according to the setting temperature

from follow-me signal every 3 minutes.

- 3) The PCB will take action to the mode change information from remote controller signal, and the follow-me function will be turned off. (if the wired remote controller does not initiate follow me function).
- 4) When the unit is running with follow-me function, if the PCB doesn't receive any signal from remote controller for 7 minutes or pressing FOLLOW ME button again, the follow-me function will be turned off automatically, and the temperature collection function of room temperature sensor will be available, the PCB will control the unit according to the room temperature detected from its own room temperature sensor and setting temperature.
- 5) When the indoor PCB receives the follow-me signal from wired remote controller, the control is the same as that from wireless remote controller, but buzzer will not respond. When the PCB receives turning-off follow-me signal from wired remote controller, the unit will quit follow-me function at once. The follow-me function controlled by wired remote controller prevails that by wireless remote controller.

### 1.3.13 8°C Heating(optional)

In heating operation, the preset temperature of the air conditioner can be as lower as 8°C, which keeps the room temperature steady at 8°C and prevents household things freezing when the house is unoccupied for a long time in severe cold weather.

### 1.3.14 Mode conflict

The indoor units cannot work cooling mode and heating at same time. Heating mode has a priority.

#### (1) Definition

	Cooling mode	Heating Mode	Fan	Off
Cooling mode	No	Yes	No	No
Heating Mode	Yes	No	Yes	No
Fan	No	Yes	No	No
Off	No	No	No	No

No: No mode conflict;

Yes: Mode conflict

#### (2) Unit action

- In case of one Indoor unit working in cooling mode or fan mode, and another indoor unit is set to heating mode, the indoor unit working in cooling mode or fan mode will change to off. The outdoor unit will change to heating mode after compressor stop 3 minutes. .
- In case of one Indoor unit working in heating mode, and another indoor unit is set to cooling mode or fan mode, the indoor unit setting to cooling mode or fan mode will change to stand by. The outdoor unit will continue working in heating mode.  
If heating mode stops (not including the indoor unit in heating mode reaching the set temperature), 3 minutes after the outdoor unit restarts and works in cooling mode or fan-only mode.

### 1.3.15 Point Check Function

There is a check switch in outdoor PCB.

Press the switch SW1 to check the states of unit when the unit is running.

Press the switch N times it will display the content corresponding to No. N. After getting into the check

function, it will display No. N with 1.5s, meanwhile the low bit decimal of digit display flashing, indicated to get into the check function display. After 1.5s, it will display the content corresponding to No. N.

The digital display tube will display the follow procedure when push SW1 each time.

	Display	Remark
0	Normal display	Display running frequency, running state or malfunction code
1	No. of indoor units in good connection	Actual data
2	Outdoor unit running mode code	Off:0,Fan only 1, Cooling:2, Heating:3, Forced cooling:4
3	A indoor unit capacity	The capacity unit is horse power. If the indoor unit is not connected, the digital display tube will show: "____" (7K:0.8HP, 9K:1HP,12K:1.2HP,18K:1.5HP)
4	B indoor unit capacity	
5	C indoor unit capacity	
6	D indoor unit capacity	
7	E indoor unit capacity	
8	A Indoor unit capacity demand code	Norm value*HP (7K:0.8HP, 9K:1HP,12K:1.2HP,18K:1.5HP)
9	B Indoor unit capacity demand code	
10	C Indoor unit capacity demand code	
11	D Indoor unit capacity demand code	
12	E Indoor unit capacity demand code	
13	Total indoor units amendatory capacity demand code	Forced cooling:7
14	The frequency corresponding to the total indoor units amendatory capacity demand	
15	The frequency after the frequency limit	
16	The frequency sending to compressor control chip	
17	A indoor unit evaporator outlet temp.(T <sub>2B</sub> A)	If the temp. is lower than -9 degree, the digital display tube will show "-9".If the temp. is higher than 70 degree, the digital display tube will show "70". If the indoor unit is not connected, the digital display tube will show: "____"
18	B indoor unit evaporator outlet temp.(T <sub>2B</sub> B)	
19	C indoor unit evaporator outlet temp.(T <sub>2B</sub> C)	
20	D indoor unit evaporator outlet temp.(T <sub>2B</sub> D)	
21	E indoor unit evaporator outlet temp.(T <sub>2B</sub> E)	
22	A indoor unit room temp.(T <sub>1</sub> A)	If the temp. is lower than 0 degree, the digital display tube will show "0".If the temp. is higher than 50 degree, the digital display tube will show "50". If the indoor unit is not connected, the digital display tube will show: "____"
23	B indoor unit room temp.(T <sub>1</sub> B)	
24	C indoor unit room temp.(T <sub>1</sub> C)	
25	D indoor unit room temp.(T <sub>1</sub> D)	
26	E indoor unit room temp.(T <sub>1</sub> E)	
27	A indoor unit evaporator temp.(T <sub>2</sub> A)	If the temp. is lower than -9 degree, the digital display tube will show "-9".If the temp. is higher than 70 degree, the digital display tube will show "70". If the indoor unit is not connected, the digital display tube will show: "____"
28	B indoor unit evaporator temp.(T <sub>2</sub> B)	
29	C indoor unit evaporator temp.(T <sub>2</sub> C)	
30	D indoor unit evaporator temp.(T <sub>2</sub> D)	
31	E indoor unit evaporator temp.(T <sub>2</sub> E)	
32	Condenser pipe temp.(T <sub>3</sub> )	
33	Outdoor ambient temp.(T <sub>4</sub> )	
34	Compressor discharge temp.(T <sub>5</sub> )	The display value is between 30~129 degree. If the temp. is lower than 30 degree, the digital display tube will show "30".If the temp. is higher than 99 degree, the digital display tube will show single digit and tens digit. For example, the digital display tube show "0.5",it means the compressor discharge temp. is 105 degree.)
35	AD value of current	The display value is hex number.
36	AD value of voltage	For example ,the digital display tube show "Cd", it means AD value is 205.
37	EXV open angle for A indoor unit	Actual data/4.

Electrical Control Function

38	EXV open angle for B indoor unit	If the value is higher than 99, the digital display tube will show single digit and tens digit. For example ,the digital display tube show "2.0",it means the EXV open angle is 120×4=480p.)		
39	EXV open angle for C indoor unit			
40	EXV open angle for D indoor unit			
41	EXV open angle for E indoor unit			
42	Frequency limit symbol	Bit7	Frequency limit caused by IGBT radiator	The display value is hex number. For example, the digital display tube show 2A,then Bit5=1, Bit3=1, Bit1=1. It means frequency limit caused by T4,T3 and current.
		Bit6	Frequency limit caused by PFC	
		Bit5	Frequency limit caused by T4.	
		Bit4	Frequency limit caused by T2.	
		Bit3	Frequency limit caused by T3.	
		Bit2	Frequency limit caused by T5	
		Bit1	Frequency limit caused by current	
		Bit0	Frequency limit caused by voltage	
43	Average value of T2	(Sum T2 value of all indoor units)/( number of indoor units in good connection)		
44	Outdoor unit fan motor state	Off:0, High speed:1, Med speed:2, Low speed:3 Breeze:4, Super breeze:5		
45	The last error or protection code	00 means no malfunction and protection		

The following items from 1.3.12.1 to 1.3.12.5 are for the explanation of the point check functions.

1.3.12.1 Frequency of compressor:

Display	Frequency of compressor (Hz)
30	30
--	Stand by
60	60

1.3.12.2 Running mode:

Display	Corresponding mode
0	Off
1	Fan only
2	Cooling mode
3	Heating mode
4	Forced cooling

1.3.12.3 Capacity demand:  
Cooling mode

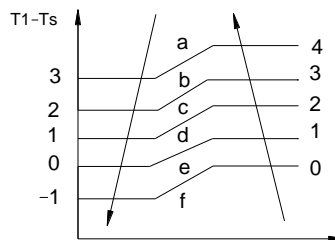

Capacity area	a	b	c	d	e	f
Norm value (N)	3	2	1.5	1	0.5	0

Heating mode

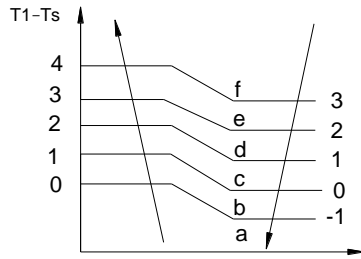

Capacity area	a	b	c	d	e	f
Norm value (N)	3	2	1.5	1	0.5	0

1.3.12.4 Number of indoor unit

Display	Number of indoor unit
1	1
2	2
3	3
4	4
5	5

1.3.12.5 Opening degree of electronic expansion valve:  
Actual opening degree equals the display data times 4

## 2. Troubleshooting

### 2.1 Display board

#### 2.1.1 Icon explanation on indoor display board (HKD& HND).

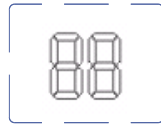

	<b>ION indication lamp(optional function):</b> This lamp illuminates when Clean Air feature is activated.
	<b>DEFROST indication lamp(For cooling &amp; heating models only):</b> Lights up when the air conditioner starts defrosting automatically or when the warm air control feature is activated in heating operation.
	<b>OPERATION indication lamp:</b> This lamp illuminates when the air conditioner is in operation.
	<b>TIMER indication lamp:</b> Lights up during Timer operation.
	<b>Temperature indicator:</b> Displays the temperature settings when the air conditioner is operational. Displays the malfunction code.

#### 2.1.2 Icon explanation on indoor display board (Duct)

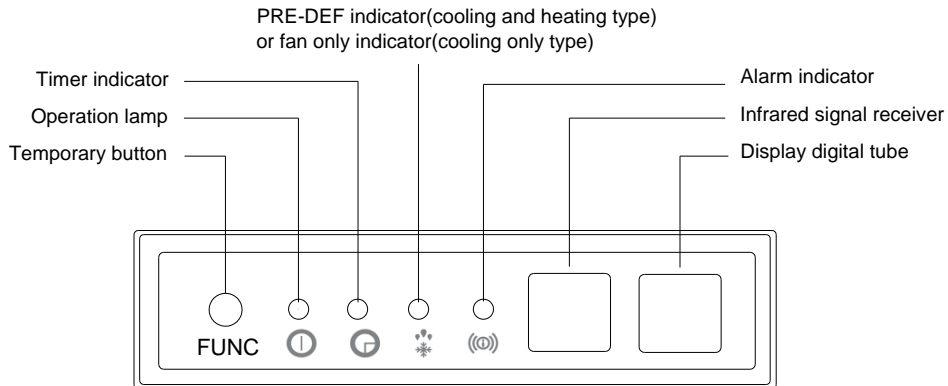

## 2.1.3 Icon explanation on indoor display board (Compact cassette).

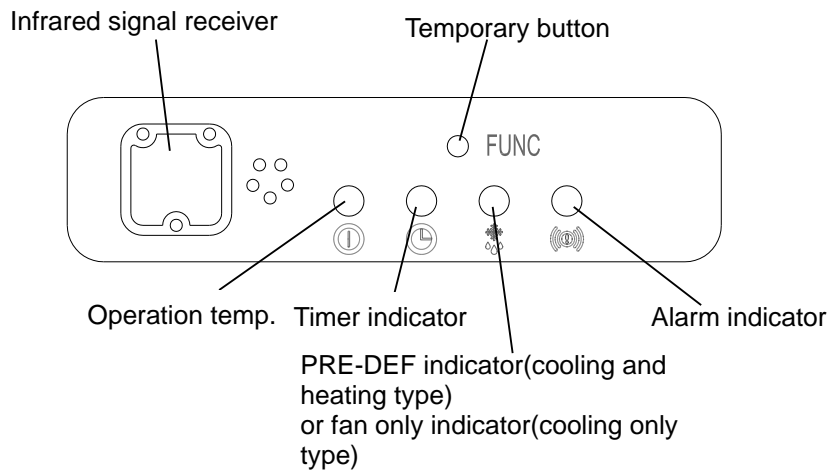

## 2.1.4 Icon explanation on indoor display board (Console)

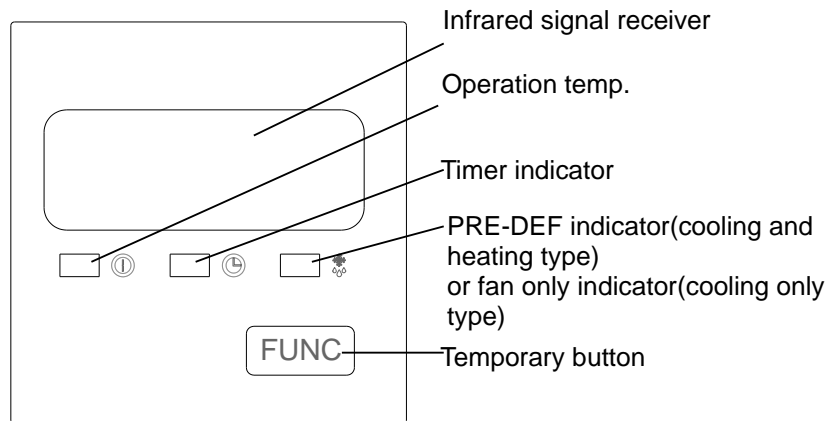

## 2.1.5 Outdoor unit's digital display tube

There is a digital display tube in outdoor PCB.

Digital display tube display function

- In standby , the LED displays “ - - ”
- In compressor operation, the LED display the running frequency,
- In defrosting mode, The LED displays “dF” or alternative displays between running frequency and “dF”(each displays 0.5s)
- In compressor pre-heating, The LED displays “PH” or alternative displays between running frequency and “PH”(each displays 0.5s)
- During the oil return process, The LED displays “RO” or alternative displays between running frequency and “RO”(each displays 0.5s)
- In low ambient cooling mode, the LED displays “LC” or alternative displays between running frequency and “LC”(each displays 0.5s)
- In forced cooling mode, the LED displays “FC” or alternative displays between running frequency and “FC”(each displays 0.5s)
- When PFC module protection occurs three times within 15 minutes, the LED displays “E6” or alternative displays between running frequency and “E6”(each displays 0.5s)
- In protection or malfunction, the LED displays error code or protection code.

## 2.2 Indoor unit malfunction For HKD,HND

Display	Operation lamp flash times	Timer lamp	Failure
E0	1	X	Indoor EEPROM malfunction
E1	2	X	Indoor / outdoor units communication error
E3	4	X	Indoor fan speed has been out of control
E4	5	X	Open or short circuit of T1 temperature sensor
E5	6	X	Open or short circuit of T2 temperature sensor
F1	2	O	Open or short circuit of T4 temperature sensor
F2	3	O	Open or short circuit of T3 temperature sensor
F3	4	O	Open or short circuit of T5 temperature sensor
F4	5	O	Outdoor EEPROM parameter error
F5	6	O	Outdoor fan speed out of control
F6	7	O	Open or short circuit of T2B temperature sensor
P0	1	☆	IPM module protection
P1	2	☆	Voltage protection
P4	5	☆	Inverter compressor drive protection
P5	6	☆	Mode conflict
P6	7	☆	Low pressure protection

O (light) X (off) ☆ (flash)

### For Cassette & Duct:

NO.	MALFUNCTION	RUN	Timer	DEF	Alarm	DISPLAY DIGITAL TUBE
1	Open or short circuit of T1 temperature sensor	☆	X	X	X	E0
2	Open or short circuit of T2 temperature sensor	X	X	☆	X	E1
3	Indoor / outdoor units communication error	X	☆	X	X	E2
4	Full-water malfunction	X	X	X	☆	E3
5	Indoor EEPROM malfunction	☆	☆	X	X	E4
6	IPM module protection	☆	X	X	O	E5
7	Open or short circuit of T3 or T4 temperature sensor or Outdoor EEPROM malfunction	☆	O	X	X	E6
8	Outdoor fan speed has been out of control	☆	O	☆	X	E7
9	Indoor fan speed has been out of control	☆	O	O	X	F5
10	Voltage protection	☆	O	X	O	P0
11	Outdoor unit over-current protection	☆	☆	☆	X	P2
12	Inverter compressor drive protection	☆	◎	X	X	P4
13	Mode conflict	☆	X	O	O	P5

☆ Flash(at 2.5Hz) ◎ Flash(at 0.5Hz) O light X (off)

Note: Digital display is only available for A5 duct type.



**For Console:**

NO.	Malfunction	Running lamp	Timer lamp	Defrosting lamp
1	Open or short circuit of T1 temperature sensor	☆	X	X
2	Open or short circuit of T2 temperature sensor	X	X	☆
3	Communication malfunction between indoor and outdoor units.	X	☆	X
4	Outdoor fan speed has been out of control	X	☆	O
5	Indoor EEPROM malfunction	☆	☆	X
6	IPM module protection	☆	X	☆
7	Open or short circuit of T3 or T4 temperature sensor or Outdoor unit EEPROM parameter error	☆	☆	☆
8	Voltage protection	☆	☆	O
9	Inverter compressor drive protection	☆	◎	X
10	Indoor fan Speed has been out of control.	☆	O	☆
11	Mode conflict	☆	X	O
O(light) X(off) ☆(flash at 5Hz) ◎(flash at 0.5Hz)				

### 2.3 Outdoor unit malfunction

Display	LED STATUS
E0	Outdoor EEPROM malfunction
E2	Indoor / outdoor units communication error
E3	Communication malfunction between IPM board and outdoor main board
E4	Open or short circuit of outdoor unit temperature sensor(T3,T4,T5,T2B)
E5	Voltage protection
E8	Outdoor fan speed has been out of control
F1	No A Indoor unit coil outlet temperature sensor or connector of sensor is defective
F2	No B Indoor unit coil outlet temperature sensor or connector of sensor is defective
F3	No C Indoor unit coil outlet temperature sensor or connector of sensor is defective
F4	No D Indoor unit coil outlet temperature sensor or connector of sensor is defective
F5	No E Indoor unit coil outlet temperature sensor or connector of sensor is defective
P1	High pressure protection (For AWAU-YCZ430-H11, AWAU-YCZ536-H11)
P2	Low pressure protection (For AWAU-YCZ430-H11, AWAU-YCZ536-H11)
P3	Current protection of compressor
P4	Temperature protection of compressor discharge
P5	High temperature protection of condenser
P6	IPM module protection

Note: Once these error codes display, they will disappear in at least 30 seconds if the unit come back to normal.(Except E3&E4)

## 2.4 Solving steps for typical malfunction

### 2.4.1 For the indoor unit

#### 2.4.1.1 Indoor EEPROM malfunction

Shut off the power supply and turn it on 1 minute later. Is it still displaying the error code?

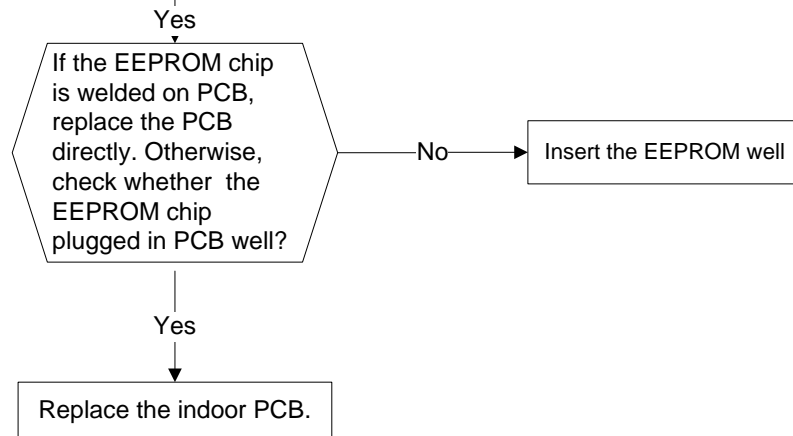

### 2.4.1.2 Indoor / outdoor units communication error

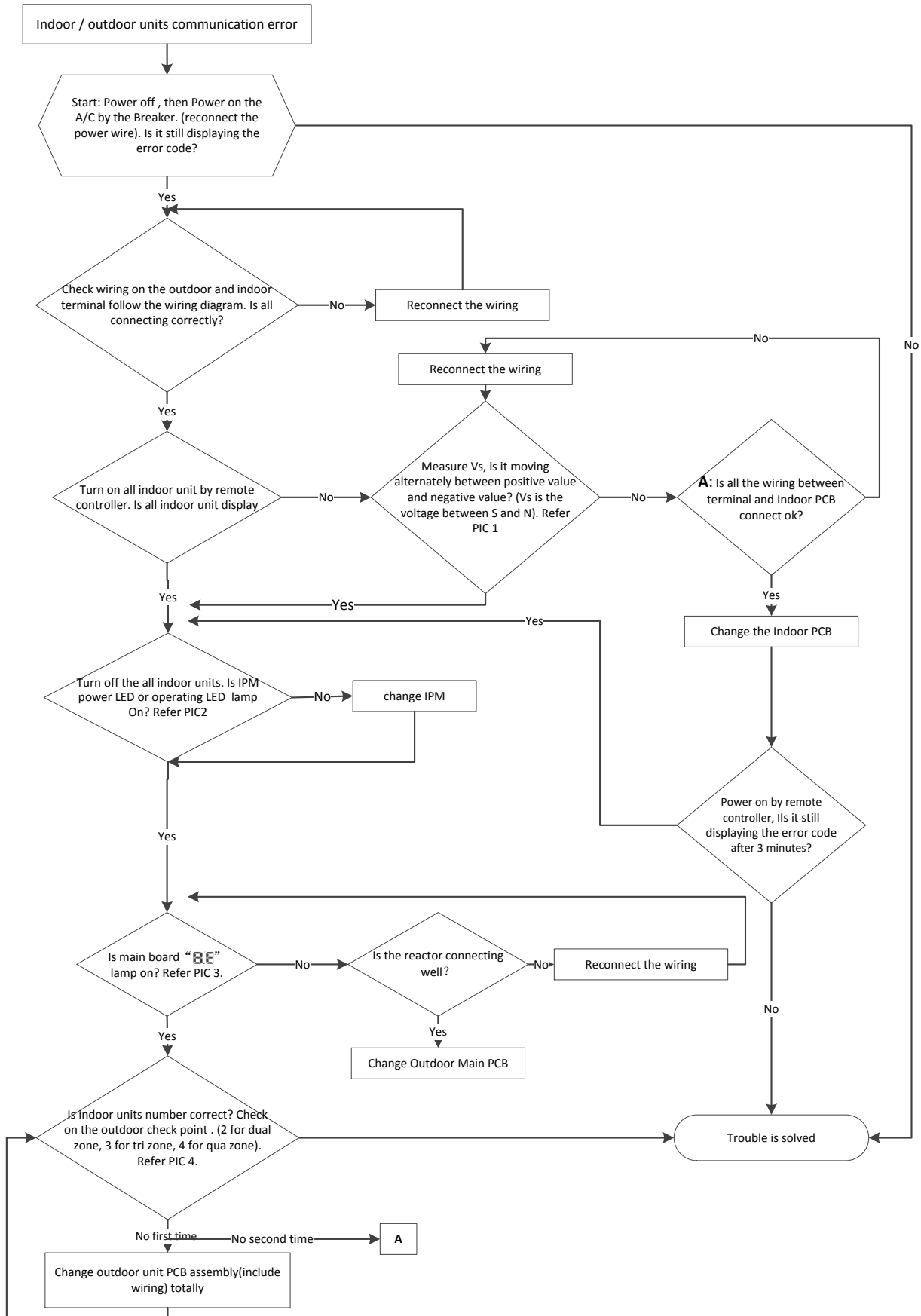



Pic 1: check the voltage of N to S (Vs), is it moving alternately between positive value and negative value?

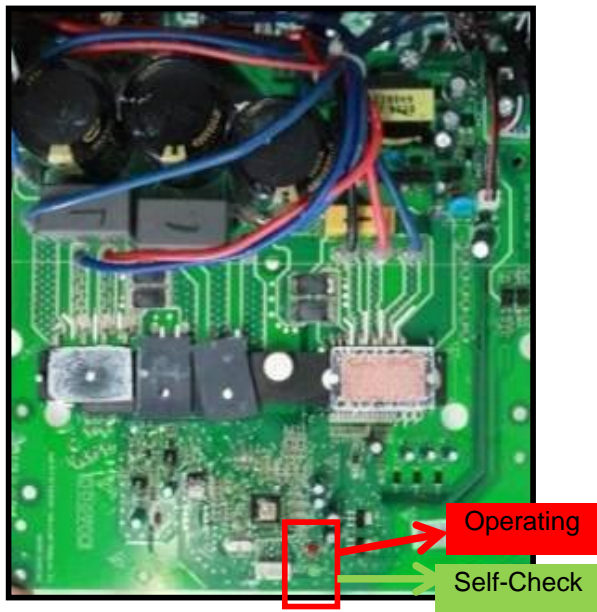

Pic 2: :IPM (For dual/tri-zone)

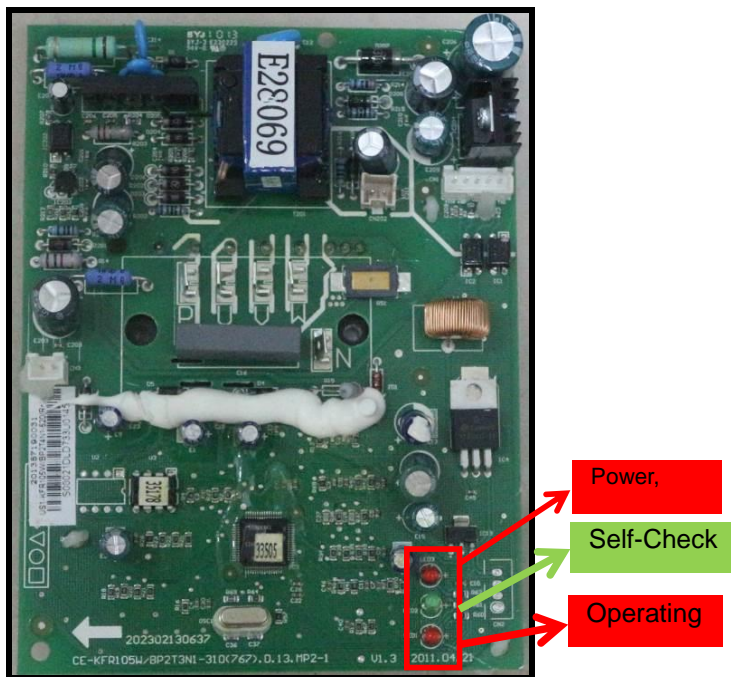

Pic 2: :IPM (For qua-zone)



PIC3 :Main board LED when power on and unit standby.



PIC 4: check point button,  
Press 1 time for check how many indoor units are connected

2.4.1.3 indoor unit fan speed has been out of control

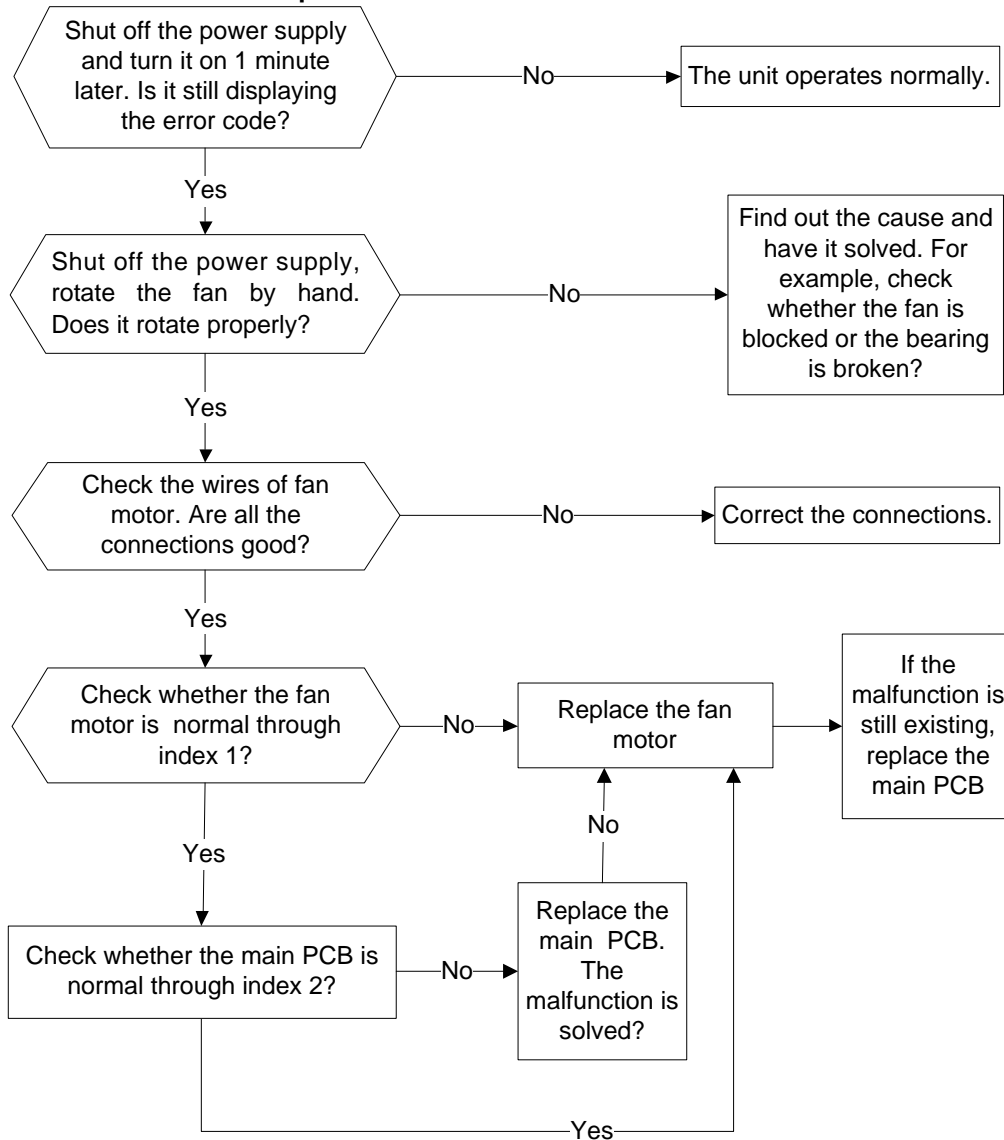

Index 1:

1. Indoor AC fan motor

Measure the resistance value of each winding by using the tester.

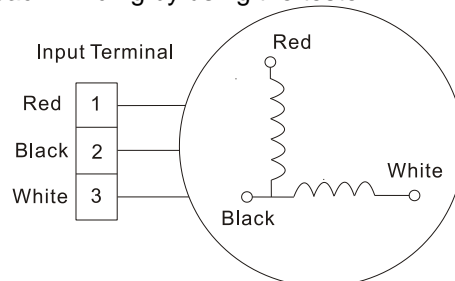

For the definite value of the resistance, refer to **2.4.3 Main parts check**.

2. Indoor DC fan motor (control chip is inside fan motor)

Measure the resistance value of each winding by using the tester. If any resistance value is zero, the fan motor must have problems and need to be replaced.

For console:

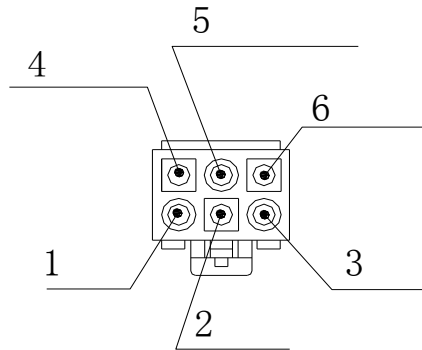

NO.	Color
1	Red
2	---
3	White
4	Blue
5	Yellow
6	Black

For other models:

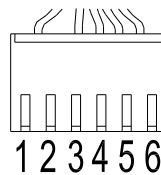

NO.	Color
1	Red
2	---
3	Black
4	White
5	Yellow
6	Blue

Index2:

1: Indoor AC fan motor

Power on and set the unit running in fan mode at high fan speed. After running for 15 seconds, measure the voltage of pin1 and pin2. If the value of the voltage is less than 100V(208~240V power supply)or 50V(115V power supply), the PCB must have problems and need to be replaced.

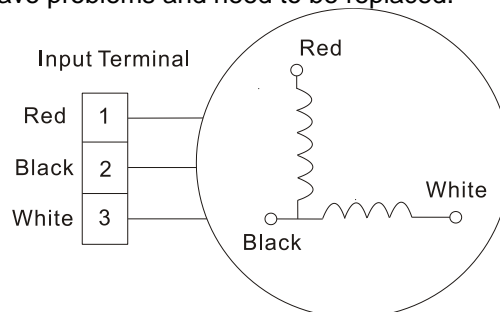

2. Indoor DC fan motor(control chip is inside fan motor)

Power on and when the unit is in standby, measure the voltage of pin1-pin3, pin4-pin3 in fan motor connector. If the value of the voltage is not in the range showing in below table, the PCB must have problems and need to be replaced.

For other models:



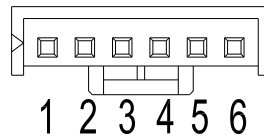

For console:

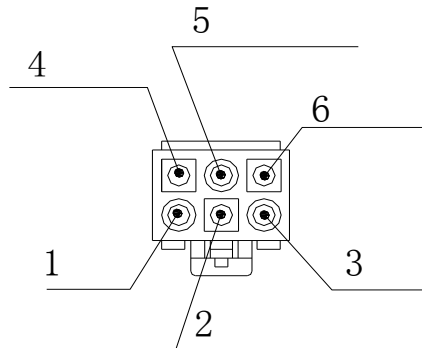

DC motor voltage input and output  
For HKD &HND:

NO.	Color	Signal	Voltage
1	Red	Vs/Vm	280V~380V
2	---	---	---
3	Black	GND	0V
4	White	Vcc	14-17.5V
5	Yellow	Vsp	0~5.6V
6	Blue	FG	14-17.5V

For Duct & Cassette:

NO.	Color	Signal	Voltage
1	Red	Vs/Vm	192V~380V
2	---	---	---
3	Black	GND	0V
4	White	Vcc	13.5-16.5V
5	Yellow	Vsp	0~6.5V
6	Blue	FG	15V

For console:

NO.	Color	Signal	Voltage
1	Red	VDC	310V
2	---	---	---
3	White	Vcc	15V
4	Blue	FG	15V
5	Yellow	Vsp	0-7.5V
6	Black	GND	0V

**2.4.1.4 Open or short circuit of temperature sensor.**

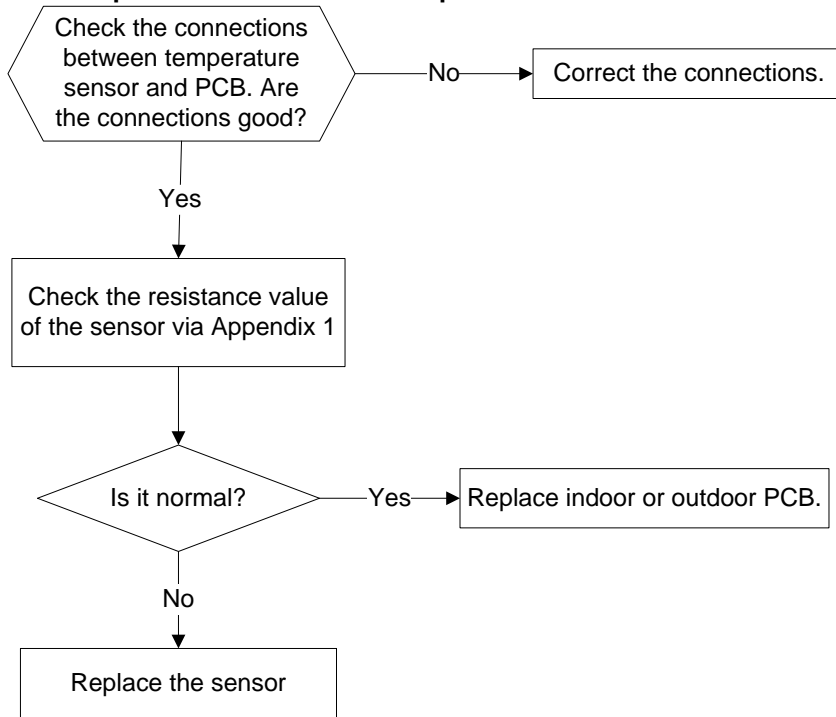

**2.4.1.5 Full-water malfunction**

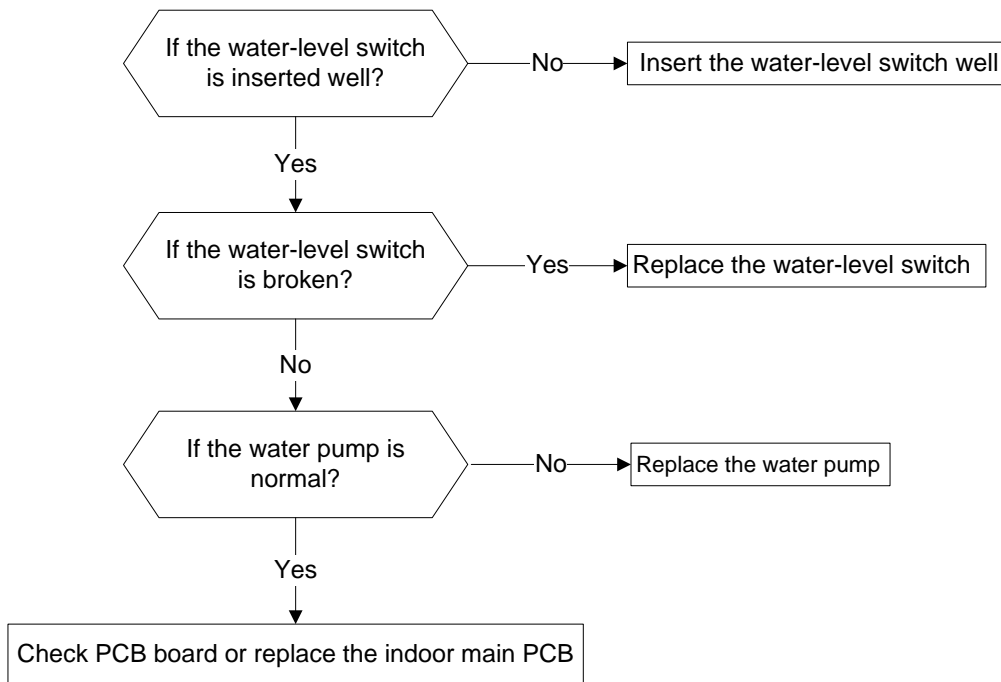

## 2.4.2 For the outdoor unit

### 2.4.2 1 Outdoor EEPROM malfunction(ODU E0)

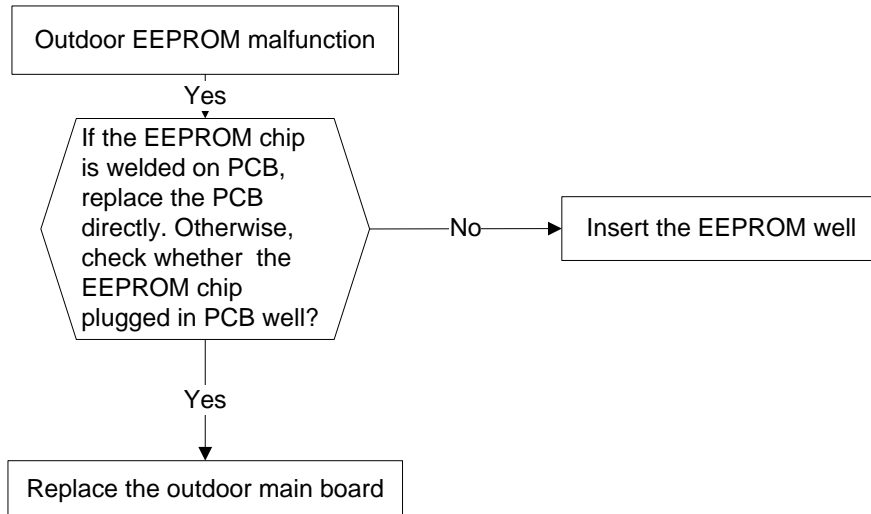

2.4.2.2 Communication malfunction between IPM board and outdoor main board(ODU E3)

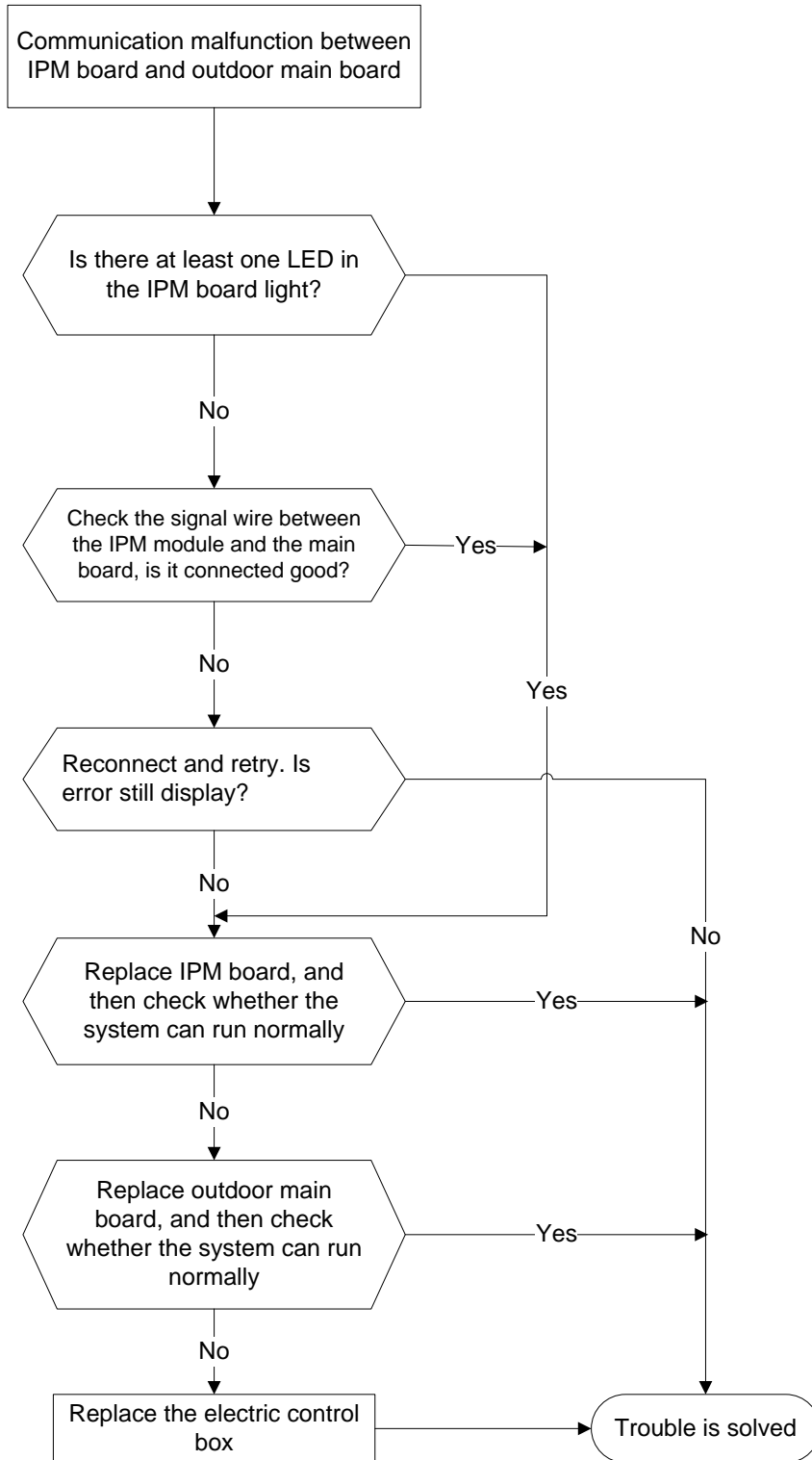

2.4.2.3 Voltage protection(ODU E5)

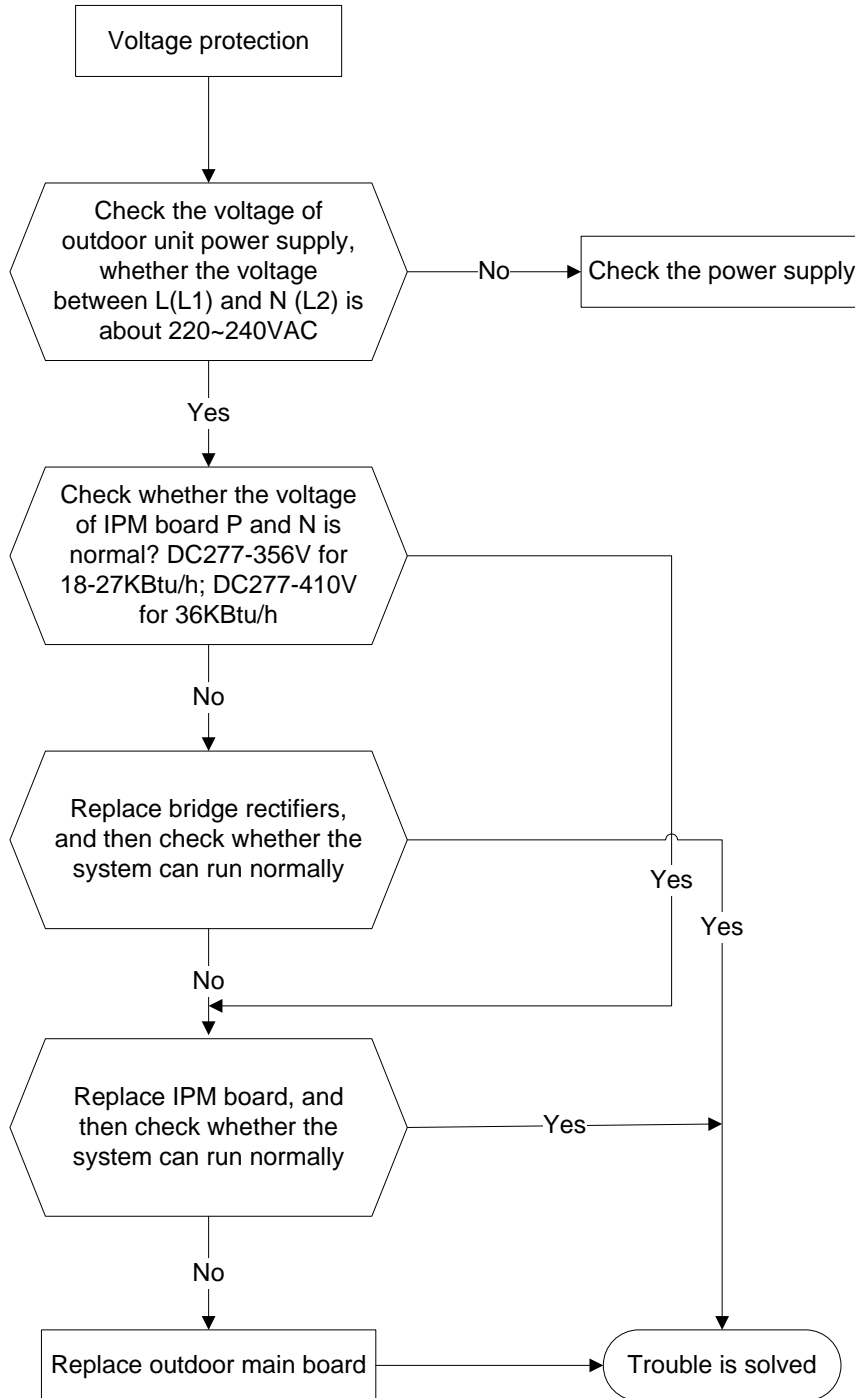

**2.4.2.4 Outdoor unit fan speed has been out of control (E8)**

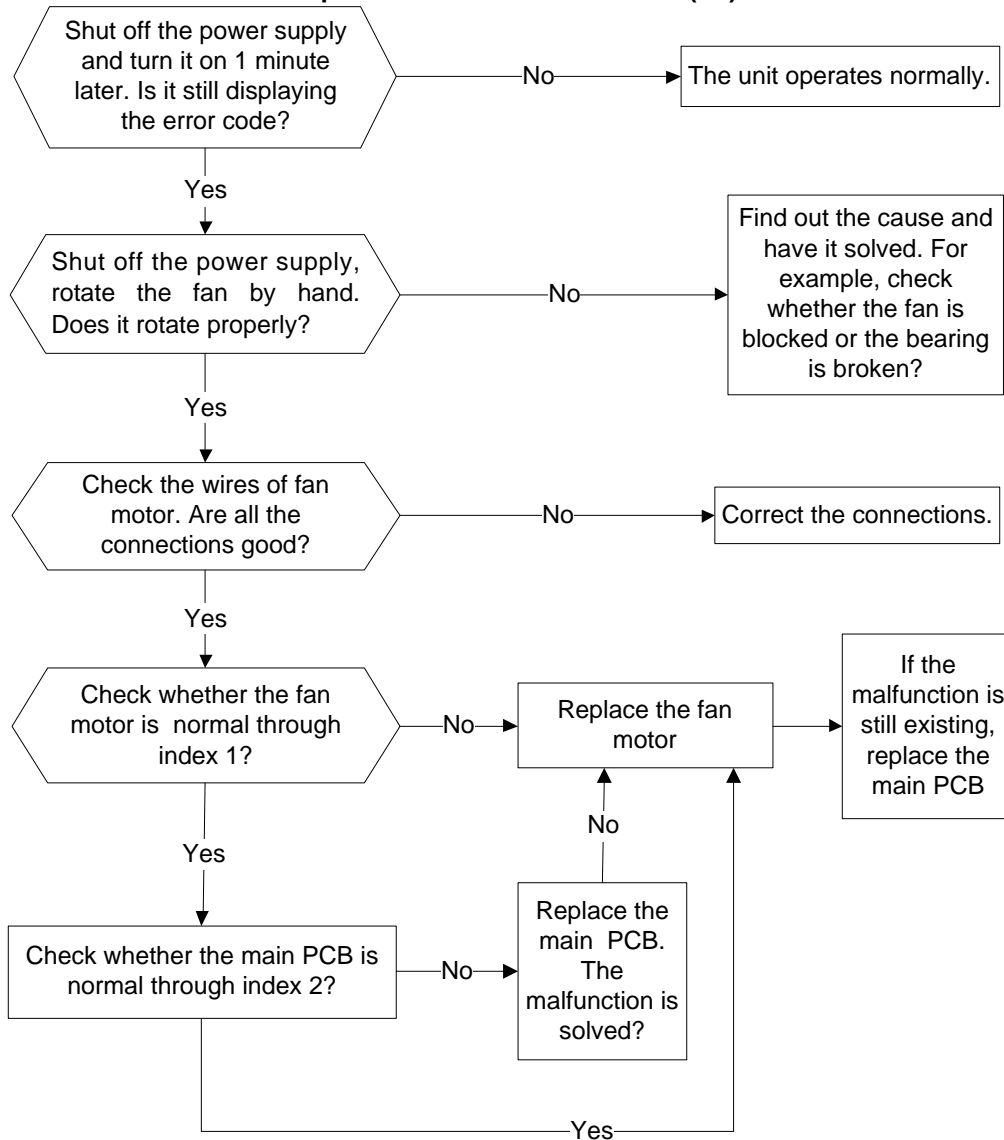

Index 1:

1.Outdoor DC fan motor(control chip is inside fan motor)

Measure the resistance value of each winding by using the tester. If any resistance value is zero, the fan motor must have problems and need to be replaced.

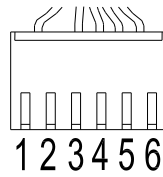

NO.	Color
1	Red
2	---
3	Black
4	White
5	Yellow
6	Blue

Index2:

1. Outdoor DC fan motor(control chip is inside fan motor)

Power on and when the unit is in standby, measure the voltage of pin1-pin3, pin4-pin3 in fan motor connector. If the value of the voltage is not in the range showing in below table, the PCB must have problems and need to be replaced.

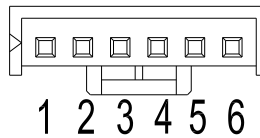

DC motor voltage input and output

NO.	Color	Signal	Voltage
1	Red	Vs/Vm	140V~380V
2	---	---	---
3	Black	GND	0V
4	White	Vcc	13.5-16.5V
5	Yellow	Vsp	0~6.5V
6	Blue	FG	15V

2.4.2.5 High pressure protection (ODU P1) (For AWAU-YCZ430-H11, AWAU-YCZ536-H11)

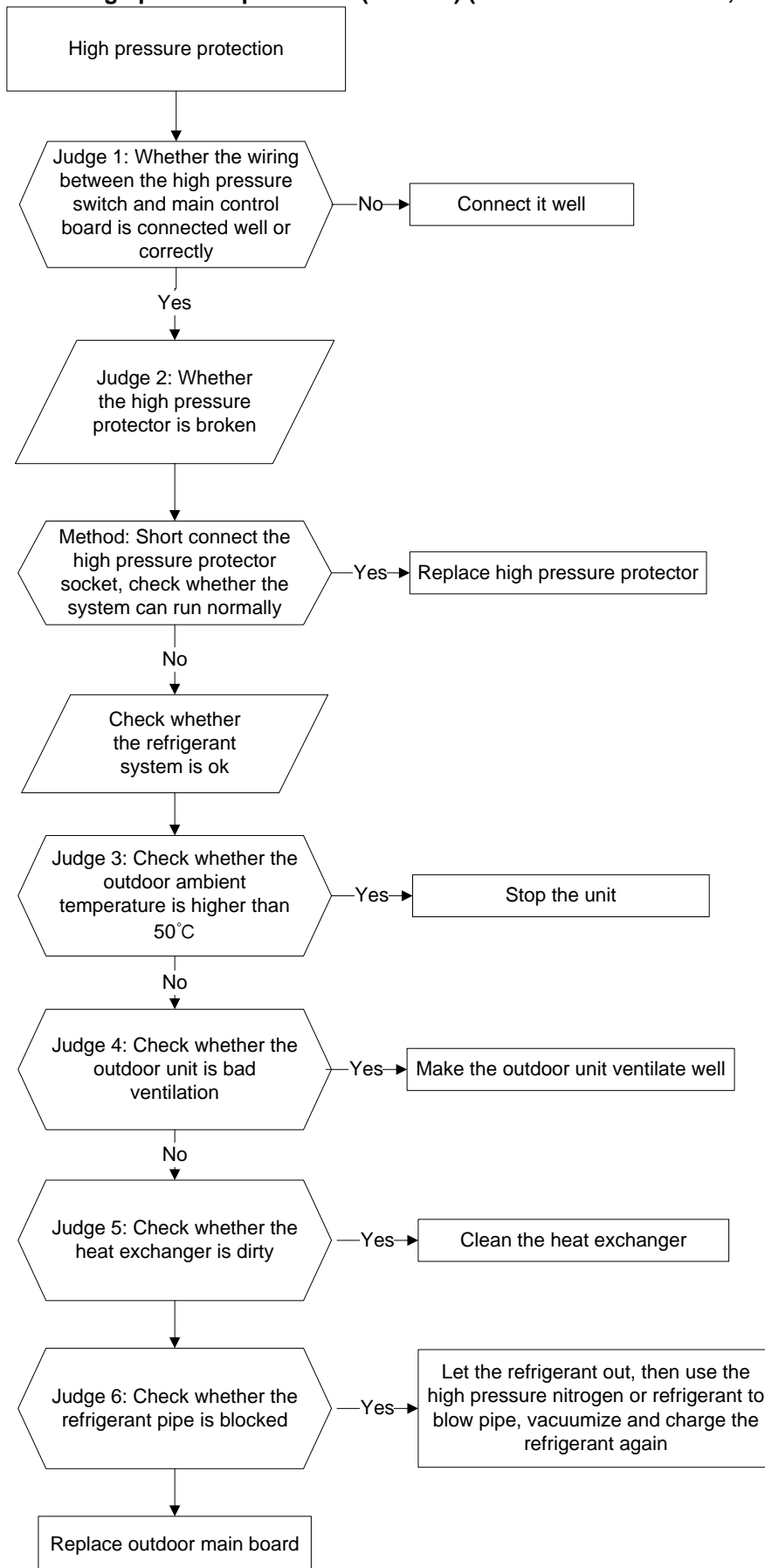



2.4.2.6 Low pressure protection (ODU P2) (For AWAU-YCZ430-H11, AWAU-YCZ536-H11)

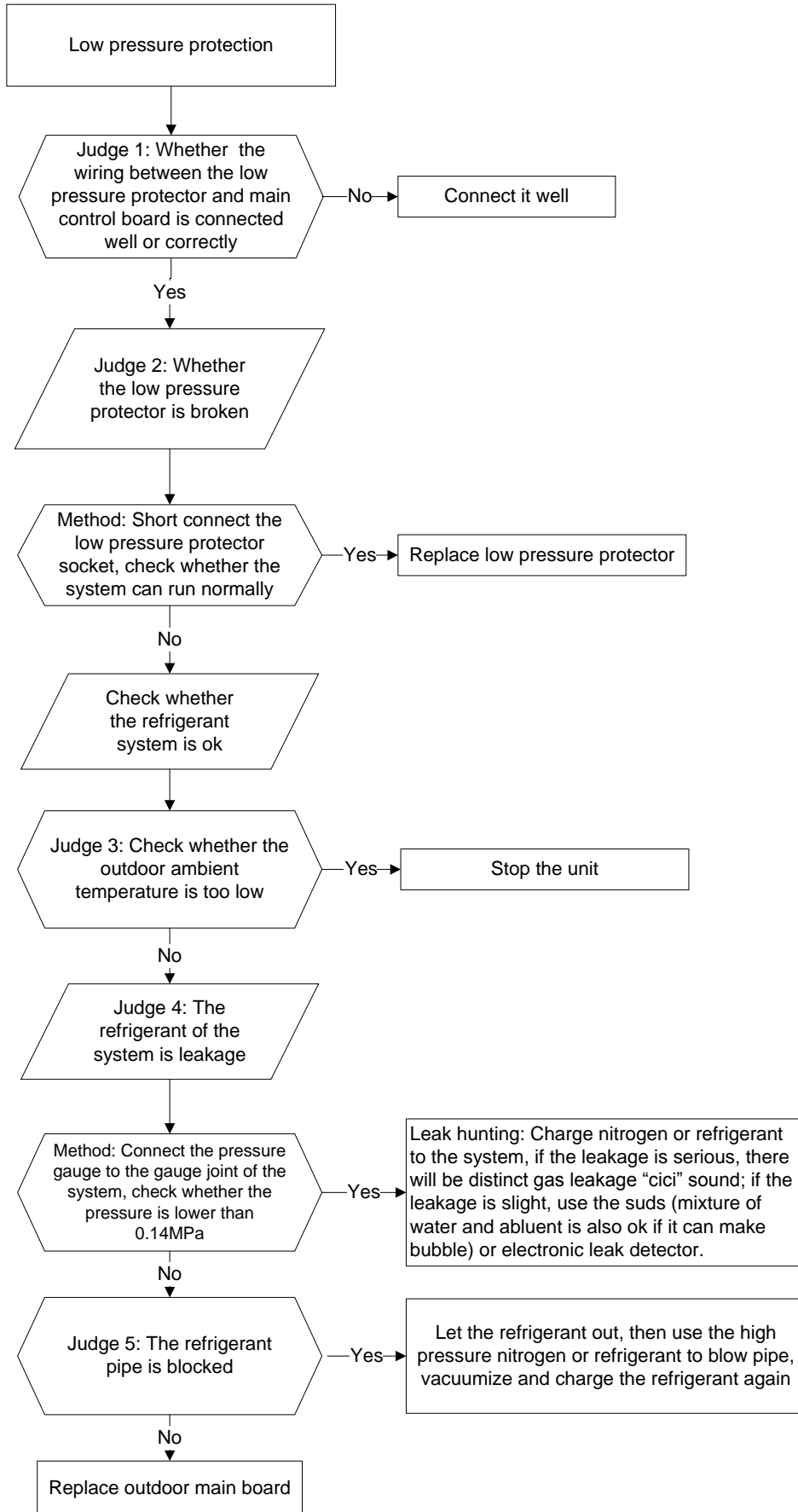

### 2.4.2.7 Current protection of compressor(ODU P3)

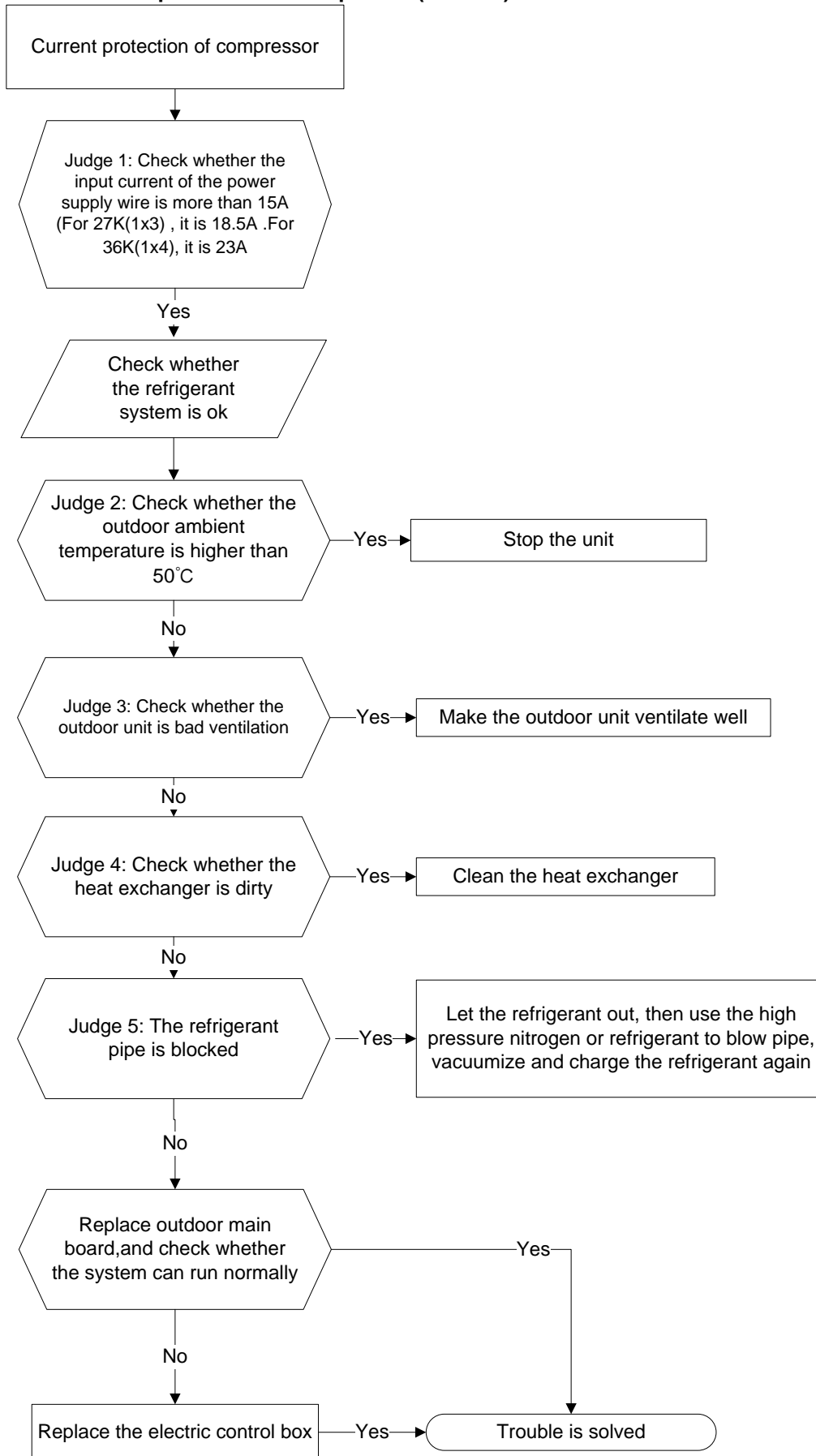

2.4.2.8 Temperature protection of compressor discharge(ODU P4)

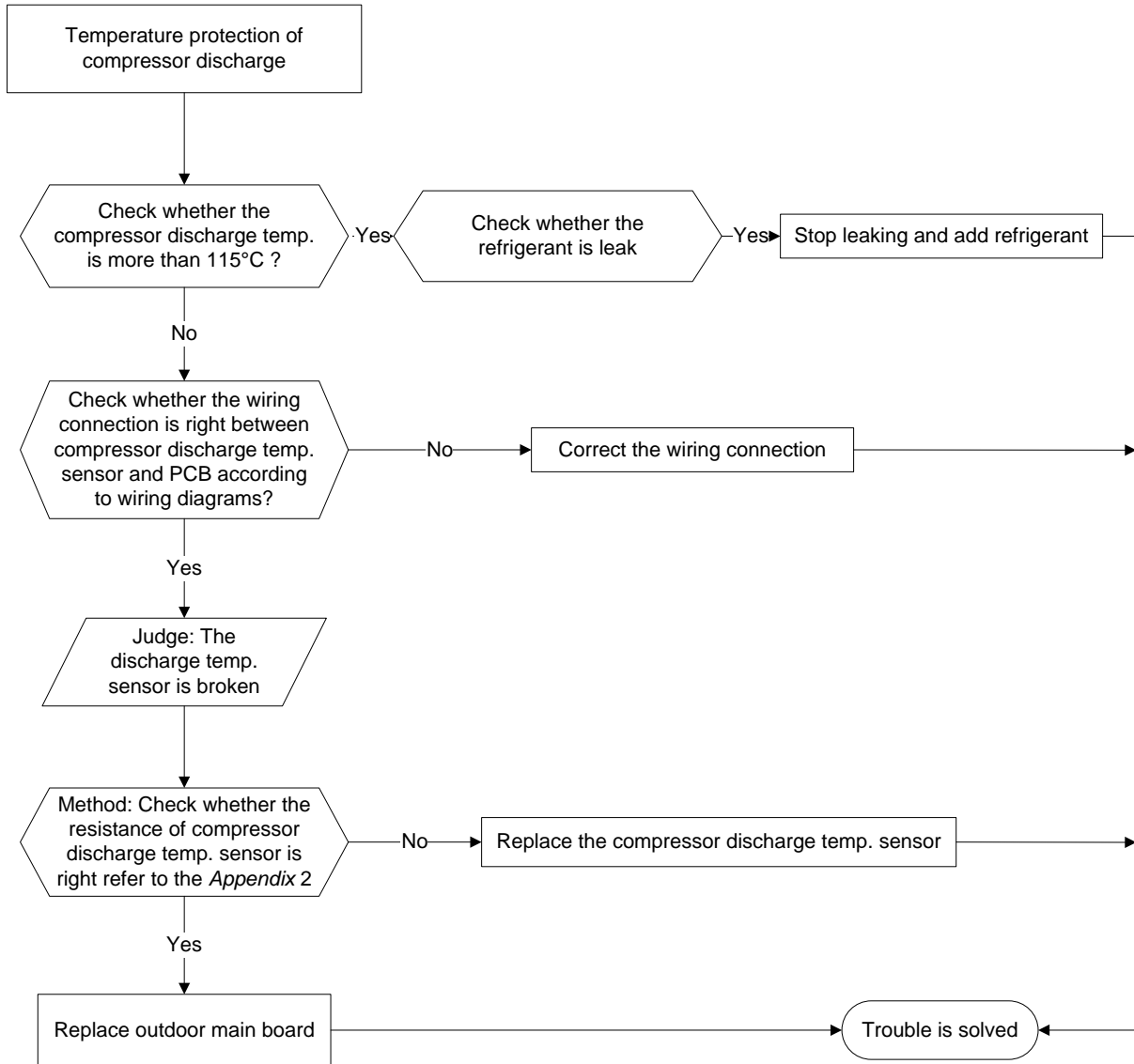

**2.4.2.9 High temperature protection of condenser(ODU P5)**

When outdoor pipe temperature is more than 65°C, the unit will stop, and unit runs again when outdoor pipe temp. less than 52°C.

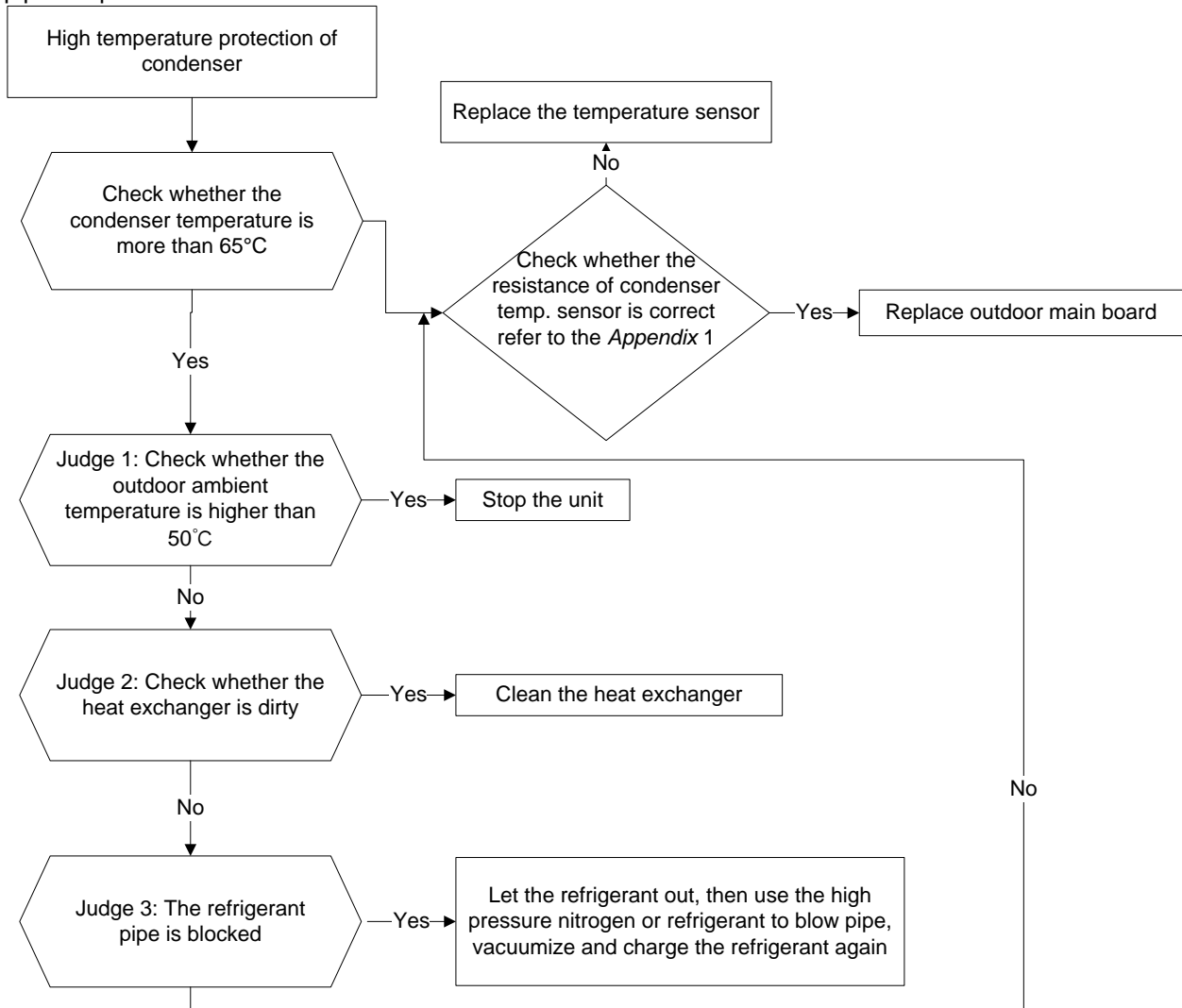

2.4.2.10 IPM module protection(ODU P6)

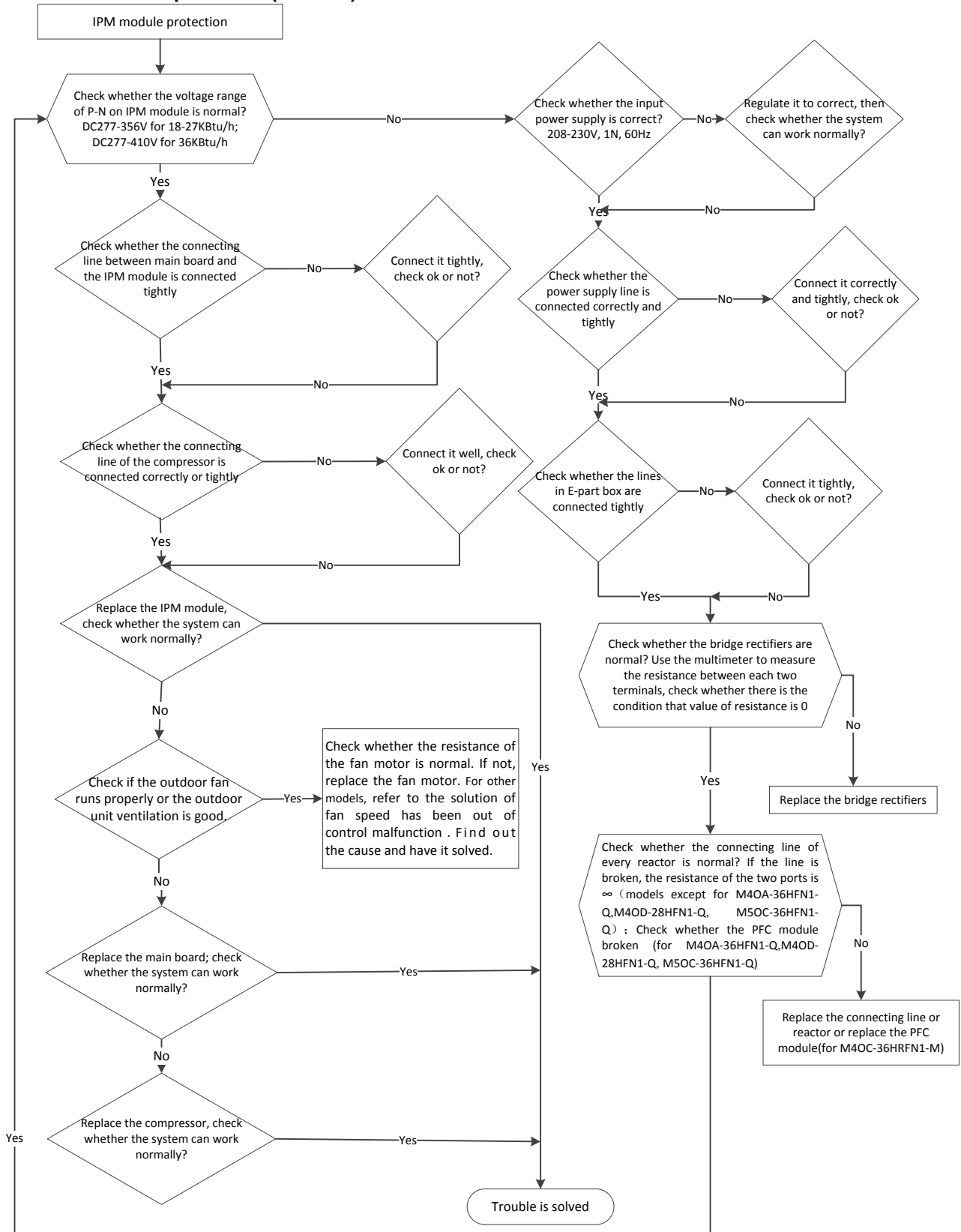

### 2.4.3 Main parts check

Spec.

Indoor unit			
Model	AWSI-HND009-N11	AWSI-HND012-N11	AWSI-HND018-N11
Indoor fan motor	WZDK20-38G	WZDK20-38G	WZDK58-38G
Model	AWSI-HKD009-N11	AWSI-HKD012-N11	AWSI-HKD018-N11
Indoor fan motor	RPG20E	WZDK20-38G	WZDK30-38G
Model	AWSI-DCD012-N11	AWSI-CBD012-N11	AWSI-XAD012-N11
Indoor fan motor	WZDK27-38GS	WZDK37-38G	RD-280-20-8A
Outdoor unit			
Model	AWAU-YCZ218-H11	AWAU-YCZ327-H11	AWAU-YCZ430-H11
Compressor	DA150S1C-20FZ	DA250S2C-30MT	DA250S2C-30MT
Outdoor fan motor	WZDK50-38G	WZDK72-38G	WZDK72-38G
Model	AWAU-YCZ536-H11		
Compressor	TNB306FPGMC-L		
Outdoor fan motor	WZDK180-38G		

### 1. Temperature sensor checking

Disconnect the temperature sensor from PCB, measure the resistance value with a tester.

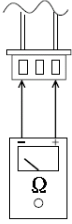

Tester

Temperature Sensors.

Room temp.(T1) sensor,

Indoor coil temp.(T2) sensor,

Outdoor coil temp.(T3) sensor,

Outdoor ambient temp.(T4) sensor,

Compressor discharge temp.(T5) sensor.

Measure the resistance value of each winding by using the multi-meter.

**Appendix 1** Temperature Sensor Resistance Value Table for T1,T2,T3,T4,T2B (°C--K)

°C	K Ohm	°C	K Ohm	°C	K Ohm	°C	K Ohm
-20	115.266	20	12.6431	60	2.35774	100	0.62973
-19	108.146	21	12.0561	61	2.27249	101	0.61148
-18	101.517	22	11.5000	62	2.19073	102	0.59386
-17	96.3423	23	10.9731	63	2.11241	103	0.57683
-16	89.5865	24	10.4736	64	2.03732	104	0.56038
-15	84.2190	25	10.000	65	1.96532	105	0.54448
-14	79.3110	26	9.55074	66	1.89627	106	0.52912
-13	74.5360	27	9.12445	67	1.83003	107	0.51426
-12	70.1698	28	8.71983	68	1.76647	108	0.49989
-11	66.0898	29	8.33566	69	1.70547	109	0.48600
-10	62.2756	30	7.97078	70	1.64691	110	0.47256
-9	58.7079	31	7.62411	71	1.59068	111	0.45957
-8	56.3694	32	7.29464	72	1.53668	112	0.44699
-7	52.2438	33	6.98142	73	1.48481	113	0.43482
-6	49.3161	34	6.68355	74	1.43498	114	0.42304
-5	46.5725	35	6.40021	75	1.38703	115	0.41164
-4	44.0000	36	6.13059	76	1.34105	116	0.40060
-3	41.5878	37	5.87359	77	1.29078	117	0.38991
-2	39.8239	38	5.62961	78	1.25423	118	0.37956
-1	37.1988	39	5.39689	79	1.21330	119	0.36954
0	35.2024	40	5.17519	80	1.17393	120	0.35982
1	33.3269	41	4.96392	81	1.13604	121	0.35042
2	31.5635	42	4.76253	82	1.09958	122	0.3413
3	29.9058	43	4.57050	83	1.06448	123	0.33246
4	28.3459	44	4.38736	84	1.03069	124	0.32390
5	26.8778	45	4.21263	85	0.99815	125	0.31559
6	25.4954	46	4.04589	86	0.96681	126	0.30754
7	24.1932	47	3.88673	87	0.93662	127	0.29974
8	22.5662	48	3.73476	88	0.90753	128	0.29216
9	21.8094	49	3.58962	89	0.87950	129	0.28482
10	20.7184	50	3.45097	90	0.85248	130	0.27770
11	19.6891	51	3.31847	91	0.82643	131	0.27078
12	18.7177	52	3.19183	92	0.80132	132	0.26408
13	17.8005	53	3.07075	93	0.77709	133	0.25757
14	16.9341	54	2.95896	94	0.75373	134	0.25125
15	16.1156	55	2.84421	95	0.73119	135	0.24512
16	15.3418	56	2.73823	96	0.70944	136	0.23916
17	14.6181	57	2.63682	97	0.68844	137	0.23338
18	13.9180	58	2.53973	98	0.66818	138	0.22776
19	13.2631	59	2.44677	99	0.64862	139	0.22231



**Appendix 2** Temperature Sensor Resistance Value Table for T5 (°C--K)

°C	K Ohm	°C	K Ohm	°C	K Ohm	°C	K Ohm
-20	542.7	20	68.66	60	13.59	100	3.702
-19	511.9	21	65.62	61	13.11	101	3.595
-18	483	22	62.73	62	12.65	102	3.492
-17	455.9	23	59.98	63	12.21	103	3.392
-16	430.5	24	57.37	64	11.79	104	3.296
-15	406.7	25	54.89	65	11.38	105	3.203
-14	384.3	26	52.53	66	10.99	106	3.113
-13	363.3	27	50.28	67	10.61	107	3.025
-12	343.6	28	48.14	68	10.25	108	2.941
-11	325.1	29	46.11	69	9.902	109	2.86
-10	307.7	30	44.17	70	9.569	110	2.781
-9	291.3	31	42.33	71	9.248	111	2.704
-8	275.9	32	40.57	72	8.94	112	2.63
-7	261.4	33	38.89	73	8.643	113	2.559
-6	247.8	34	37.3	74	8.358	114	2.489
-5	234.9	35	35.78	75	8.084	115	2.422
-4	222.8	36	34.32	76	7.82	116	2.357
-3	211.4	37	32.94	77	7.566	117	2.294
-2	200.7	38	31.62	78	7.321	118	2.233
-1	190.5	39	30.36	79	7.086	119	2.174
0	180.9	40	29.15	80	6.859	120	2.117
1	171.9	41	28	81	6.641	121	2.061
2	163.3	42	26.9	82	6.43	122	2.007
3	155.2	43	25.86	83	6.228	123	1.955
4	147.6	44	24.85	84	6.033	124	1.905
5	140.4	45	23.89	85	5.844	125	1.856
6	133.5	46	22.89	86	5.663	126	1.808
7	127.1	47	22.1	87	5.488	127	1.762
8	121	48	21.26	88	5.32	128	1.717
9	115.2	49	20.46	89	5.157	129	1.674
10	109.8	50	19.69	90	5	130	1.632
11	104.6	51	18.96	91	4.849		
12	99.69	52	18.26	92	4.703		
13	95.05	53	17.58	93	4.562		
14	90.66	54	16.94	94	4.426		
15	86.49	55	16.32	95	4.294	B(25/50)=3950K	
16	82.54	56	15.73	96	4.167		
17	78.79	57	15.16	97	4.045	R(90°C)=5KΩ±3%	
18	75.24	58	14.62	98	3.927		
19	71.86	59	14.09	99	3.812		

## 2.Compressor checking

Measure the resistance value of each winding by using the tester.

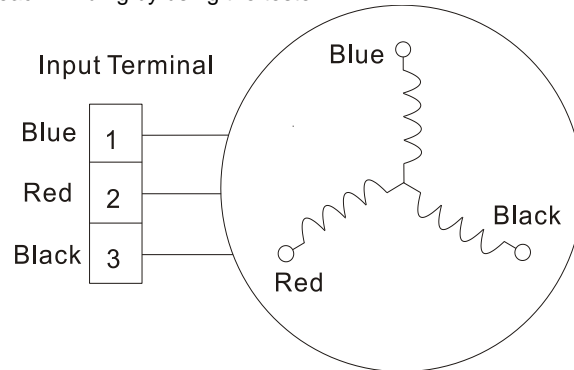

Position	Resistance Value		
		DA150S1C-20FZ	DA250S2C-30MT
Blue - Red	0.95Ω(20℃)	0.55Ω(20℃)	0.53Ω(20℃)



### 3. IPM continuity check

Turn off the power, let the large capacity electrolytic capacitors discharge completely, and dismount the IPM. Use a digital tester to measure the resistance between P and UVWN; UVW and N.

Digital tester		Normal resistance value	Digital tester		Normal resistance value
(+)Red	(-)Black		(+)Red	(-)Black	
P	N	∞ (Several MΩ)	U	N	∞ (Several MΩ)
	U		V		
	V		W		
	W		(+)Red		

### 4: Indoor AC Fan Motor

Measure the resistance value of each winding by using the tester.

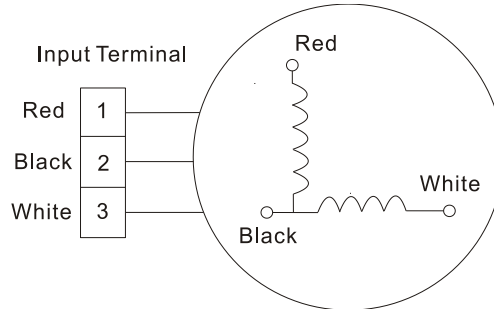

Position	Resistance Value	
	RPG20E(TongDe)	RPG20E(Weilng)
Black - Red	415Ω±8% (20℃)	387Ω±8% (20℃)
Red - Yellow	396Ω±8% (20℃)	378Ω±8% (20℃)
Yellow - Blue	396Ω±8% (20℃)	378Ω±8% (20℃)



SERVICE MANUAL

## **Multi Splits Series**