

Airwell

Service Manual

YBZ214-318-430

Indoor Units		Outdoor Units
AWSI-HZD009-H11	AWSI-HYD009-H11	AWAU-YBZ214-H11
AWSI-HZD012-H11	AWSI-HYD012-H11	AWAU-YBZ318-H11
AWSI-HZD018-H11	AWSI-HYD018-H11	AWAU-YBZ430-H11



REFRIGERANT

R410A

HEAT PUMP

SM YBZ H11 1-A.1 GB

JUNE- 2011

Version:2

LIST OF EFFECTIVE PAGES

Note: Changes in the pages are indicated by “Revision #” in the footer of each effected page (when none indicates any changes in the relevant page). All pages in the following list represent effected/ non effected pages divided by chapters.

Dates of issue for original and changed pages are:

Original 01..... 14 Nov, 10

Total number of pages in this publication is **85** consisting of the following:

Page No.	Revision No. #	Page No.	Revision No. #	Page No.	Revision No. #
----------	----------------	----------	----------------	----------	----------------

* Zero in this column indicates an original page.

Table of Contents

1.	INTRODUCTION.....	1-1
2.	PRODUCT DATA SHEET.....	2-1
3.	RATING CONDITIONS.....	3-1
4.	OUTLINE DIMENSION.....	4-1
5.	PERFORMANCE DATA.....	5-1
6.	PRESSURE CURVES.....	6-1
7.	SOUND LEVEL CHARACTERISTICS.....	7-1
8.	ELECTRICAL DATA.....	8-1
9.	WIRING DIAGRAM.....	9-1
10.	REFRIGERATION DIAGRAMS.....	10-1
11.	TUBING CONNECTIONS.....	11-1
12.	CONTROL SYSTEM.....	12-1
13.	TROUBLESHOOTING.....	13-1
14.	CHARACTERISTICS OF SENSOR.....	14-1
15.	EXPLODED VIEW & SPARE PART LIST.....	15-1

1. INTRODUCTION

1.1 General

The YBZ DC inverter multisplits outdoor is a multi-tubing system with 2, 3 or 4 connected indoor units. The multi-split inverter is a high level technology product for residential and commercial application offering comfort, low noise operation and energy saves.

1.2 Main Features

The unit benefits from the most advanced technological innovations, namely:

- DC inverter technology.
- R410A models
- Microprocessor control and indoor LED display
- High COP, Energy efficiency class A in cooling/heating mode
- Max allowing total tubing distance of 70m(for model 18,30)
- Up to 10 m vertical high between indoor and outdoor units(for model 18,30)
- Easy installation and service.
- Sleep mode from remote control to save energy
- ON/OFF timer and clock display
- Vertical auto swing with motorized flap (any position stop)
- Intelligent Deicing
- Memory from power failure
- Rapid cooling/heating
- I-Feel function
- Cold air prevention in heating
- Clean function (Blow dry)
- Self diagnostic (Error indications) for ease of maintenance

1.3 Indoor Unit

The indoor unit is wall mounted, and can be easily fitted to many types of residential locations. It includes:

- LED display
- Variable speed with PG motor
- Motorized flap
- High efficiency filtration to ensure a best Air Quality: Advanced filtering combine mechanical, Photo-catalytic + Bi-anti bacterial and observe bad gaseous and smokes.

1.4 Control

The microprocessor indoor controller, and an infrared remote control, supplied as standard, provides complete operating function and programming.

Remote control RC 8:

Compact and economically design, it offers excellent user comfort. Combining modern design with high technology, the RC8 remote control offers powerful functions of real considering of user comfort and energy saving of air-conditioner.

For detail of functions, please refer to Appendix 1

1.5 Outdoor Unit

The outdoor units can be installed as floor or wall mounted units by using a wall supporting bracket. The metal sheets are protected by anti- corrosion paint work allowing long life resistance. All outdoor units are pre-charged. For further information please refer to the Product Data Sheet, Chapter 2.

It includes:

- Compressor mounted in a soundproofed compartment :
- Axial fan.
- Outdoor coil with hydrophilic louver fins for RC units.
- Outlet air fan grill.
- Interconnecting wiring terminal block.
- Electric expansion valves to control the refrigerant to each indoor.





1.6 Tubing Connections





Flare type interconnecting tubing to be produced on site.
For further details please refer to the Installation Manual.

1.7 Inbox Documentation

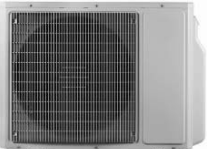
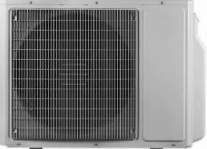
Each unit is supplied with its own installation, operation and remote control manuals.

1.8 Matching Table

OUTDOOR UNITS	INDOOR UNITS		
	AWSI-HZD009-H11	AWSI-HZD012-H11	AWSI-HZD018-H11
			
 AWAU-YBZ214-H11	X	X	
 AWAU-YBZ318-H11	X	X	X
 AWAU-YBZ430-H11	X	X	X

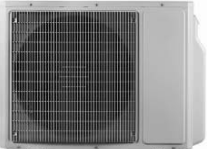
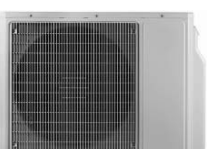
OUTDOOR UNITS	INDOOR UNITS		
	AWSI-HYD009-H11	AWSI-HYD012-H11	AWSI-HYD018-H11
			
 AWAU-YBZ214-H11	X	X	
 AWAU-YBZ318-H11	X	X	X
 AWAU-YBZ430-H11	X	X	X

1.9 Indoor unit combination

AWAU-YBZ214-H11 ELAU-VBZ214-H11 JOAU-ZBY214-H11	
1 unit	2 units
9	9+9
12	9+12

AWAU-YBZ318-H11 ELAU-VBZ318-H11				
2 units		3 units		
9+9	9+12	9+9+9	9+9+12	9+9+18
9+18	12+12	9+18+18	9+12+12	9+12+18
12+18	18+18	12+12+12	12+12+18	12+18+18

AWAU-YBZ430-H11 ELAU-VBZ430-H11							
2 units		3 units			4 units		
9+9	9+12	9+9+9	9+9+12	9+9+18	9+9+9+9	9+9+9+12	9+9+9+18
9+18	12+12	9+18+18	9+12+12	9+12+18	9+9+12+12	9+9+12+18	9+9+18+18
12+18	18+18	12+12+12	12+12+18	12+18+18	9+12+12+12	9+12+12+18	9+12+18+18
					12+12+12+12	12+12+12+18	12+12+18+18

2. PRODUCT DATA SHEET

Model Outdoor Unit		YBZ214		
Installation Method of Pipe		Flared		
Characteristics	Units	Cooling	Heating	
Capacity (4)	kW	3.90(2.00-4.70)	4.30(2.50-5.50)	
Power input (4)	kW	1.14(0.50-2.00)	1.13(0.58-2.15)	
EER (Cooling) or COP(Heating) (4)	W/W	3.42	3.80	
Energy efficiency class		A	A	
Power supply	V	220-240		
	Ph	1		
	Hz	50		
Rated current	A	5.11	5.06	
Power factor		0.97	0.97	
Prated (IDU+ODU)	W			
Starting current	A			
Circuit breaker rating	A	25		
OUTDOOR	Refrigerant control		EEV	
	Compressor type, model		Sanyo Twin Rotary,C-6RZ146H1A	
	Fan type & quantity		Propeller(direct) x 1	
	Fan speeds	H	RPM	880/700/500
	Air flow	H	m3/hr	2600/2300/1600
	Sound power level	H	dB(A)	66
	Sound pressure level(3)	H	dB(A)	56
	Dimensions	WxHxD	mm	899X596X378
	Net Weight		kg	43
	Package dimensions	WxHxD	mm	980X420X645
	Packaged weight		kg	48
	Refrigerant type		R410A	
	Standard charge		kg	1.4
	Additional charge		20g/m(10m<L<20m)	
	Connections between units	Liquid line	In.(mm)	2x1/4"(6.35)
		Suction line	In.(mm)	2x3/8"(9.53)
Max.tubing length		m.	Max.10m for one unit and 20m for total	
height difference between indoor units		m	Max. 5	
height difference between indoor & outdoor		m.	Max. 5	

Model Outdoor Unit		YBZ318		
Installation Method of Pipe		Flared		
Characteristics	Units	Cooling	Heating	
Capacity (4)	kW	6.80(2.20-10.00)	8.00(2.80-11.00)	
Power input (4)	kW	2.11(0.65-4.50)	2.21(0.98-3.95)	
EER (Cooling) or COP(Heating) (4)	W/W	3.22	3.62	
Energy efficiency class		A	A	
Power supply	V	220-240		
	Ph	1		
	Hz	50		
Rated current	A	9.45	9.90	
Power factor		0.97	0.97	
Prated (IDU+ODU)	W			
Starting current	A			
Circuit breaker rating	A	32		
OUTDOOR	Refrigerant control	EEV		
	Compressor type, model	Mitsubishi Twin Rotary, TNB220FLHMC		
	Fan type & quantity	Propeller(direct) x 1		
	Fan speeds	H	RPM	690/600/500
	Air flow	H	m3/hr	3300/2900/2400
	Sound power level	H	dB(A)	68
	Sound pressure level(3)	H	dB(A)	58
	Dimensions	WxHxD	mm	955X700X396
	Net Weight		kg	59
	Package dimensions	WxHxD	mm	1029X458X750
	Packaged weight		kg	64
	Refrigerant type		R410A	
	Standard charge		kg	2.2
	Additional charge		20g/m(30m<L<70m)	
	Connections between units	Liquid line	In.(mm)	3x1/4"(6.35)
Suction line		In.(mm)	3x3/8"(9.53)	
Max.tubing length		m	Max.20m for one unit and 70m for total	
height difference between indoor units		m	Max. 10	
height difference between indoor & outdoor		m	Max. 10	

Model Outdoor Unit			YBZ318		
Installation Method of Pipe			Flared		
Characteristics		Units	Cooling	Heating	
Capacity (4)		kW	7.80(2.20-10.00)	8.70(2.80-11.00)	
Power input (4)		kW	2.42(0.65-4.50)	2.40(0.98-3.95)	
EER (Cooling) or COP(Heating) (4)		W/W	3.22	3.63	
Energy efficiency class			A	A	
Power supply		V	220-240		
		Ph	1		
		Hz	50		
Rated current		A	10.8	10.7	
Power factor			0.97	0.97	
Prated (IDU+ODU)		W			
Starting current		A			
Circuit breaker rating		A	32		
OUTDOOR	Refrigerant control		EEV		
	Compressor type, model		Mitsubishi Twin Rotary, TNB220FLHMC		
	Fan type & quantity		Propeller(direct) x 1		
	Fan speeds	H	RPM	690/600/500	
	Air flow	H	m3/hr	3300/2900/2400	
	Sound power level	H	dB(A)	68	
	Sound pressure level(3)	H	dB(A)	58	
	Dimensions	WxHxD	mm	955X700X396	
	Net Weight		kg	60	
	Package dimensions	WxHxD	mm	1029X458X750	
	Packaged weight		kg	65	
	Refrigerant type			R410A	
	Standard charge		kg	2.2	
	Additional charge			20g/m(40m<L<70m)	
	Connections between units	Liquid line	In.(mm)	4x1/4"(6.35)	
		Suction line	In.(mm)	4x3/8"(9.53)	
Max.tubing length		m.	Max.20m for one unit and 70m for total		
height difference between indoor units		m.	Max. 10		
height difference between indoor & outdoor		m.	Max. 10		

Model Indoor Unit				HZD/HYD009		
Installation Method of Pipe				Flared		
Characteristics			Units	Cooling	Heating	
Capacity (4)			kW	2.60	2.80	
Power supply			V	220-240		
			Ph	1		
			Hz	50		
INDOOR	Fan type & quantity				Crossflow x 1	
	Fan speeds	Cooling	SH/H/M/L	RPM	1300/1100/900/700	
		Heating	SH/H/M/L	RPM	1300/1140/980/820	
	Air flow (1)		SH/H/M/L	m3/hr	600/500/350/280	
	External static pressure		Min	Pa	0	
	Sound power level (2)		SH/H/M/L	dB(A)	51/48/40/34/-	
	Sound pressure level(3)		SH/H/M/L	dB(A)	41/38/30/24/-	
	Moisture removal			l/hr	0.8	
	Condensate drain tube I.D			mm	16	
	Dimensions		WxHxD	mm	770x283x201	
	Net Weight			kg	8	
	Package dimensions		WxHxD	mm	844x342x261	
	Packaged weight			kg	11	
Operation control type					Remote control	

Model Indoor Unit				HZD/HYD012		
Installation Method of Pipe				Flared		
Characteristics			Units	Cooling	Heating	
Capacity (4)			kW	3.50	3.80	
Power supply			V	220-240		
			Ph	1		
			Hz	50		
INDOOR	Fan type & quantity				Crossflow x 1	
	Fan speeds	Cooling	SH/H/M/L	RPM	1350/1150/950/750	
		Heating	SH/H/M/L	RPM	1350/1190/1020/850	
	Air flow (1)		SH/H/M/L	m3/hr	680/560/410/300	
	External static pressure		Min	Pa	0	
	Sound power level (2)		SH/H/M/L	dB(A)	52/49/41/35/-	
	Sound pressure level(3)		SH/H/M/L	dB(A)	42/39/31/25/-	
	Moisture removal			l/hr	1.5	
	Condensate drain tube I.D			mm	16	
	Dimensions		WxHxD	mm	770x283x201	
	Net Weight			kg	9	
	Package dimensions		WxHxD	mm	844x342x261	
	Packaged weight			kg	12	
Operation control type					Remote control	

Model Indoor Unit				HZD/HYD018		
Installation Method of Pipe				Flared		
Characteristics			Units	Cooling	Heating	
Capacity (4)			kW	5.30	5.80	
Power supply			V	220-240		
			Ph	1		
			Hz	50		
INDOOR	Fan type & quantity			Crossflow x 1		
	Fan speeds	Cooling	SH/H/M/L	RPM	1300/1100/950/800	
		Heating	SH/H/M/L	RPM	1400/1200/1050/900	
	Air flow (1)		SH/H/M/L	m3/hr	800/680/560/460	
	External static pressure		Min	Pa	0	
	Sound power level (2)		SH/H/M/L	dB(A)	55/50/47/42/-	
	Sound pressure level(3)		SH/H/M/L	dB(A)	45/40/37/32/-	
	Moisture removal			l/hr	2	
	Condensate drain tube I.D			mm	16	
	Dimensions		WxHxD	mm	865x305x215	
	Net Weight			kg	12	
	Package dimensions		WxHxD	mm	948X383X310	
Packaged weight			kg	16		
Operation control type				Remote control		

- (1)Airflow in ducted units; at nominal external static pressure.
- (2)Sound power in ducted units is measured at air discharge.
- (3)Sound pressure level measured at 1-meter distance from unit.
- (4)Rating conditions in accordance to ISO 5151 and ISO 13253 (for ducted units).

3. RATING CONDITIONS

Rating conditions in accordance with ISO 5151 and ISO 13253 (for ducted units).

Cooling:

Indoor: 27°C DB 19°C WB

Outdoor: 35°C DB

Heating:

Indoor: 20°C DB

Outdoor: 7°C DB 6°C WB

Operating Limits

R410A

		Indoor	Outdoor
Cooling	Upper limit	32°C DB 23°C WB	43°C DB
	Lower limit	21°C DB 15°C WB	-5°C DB
Heating	Upper limit	27°C DB	24°C DB 18°C WB
	Lower limit	10°C DB	-15°C DB RH80%
Voltage		1-PH 50Hz 195 – 265 V	

4. OUTLINE DIMENSION

4.1 Indoor: HZD009, HZD012, HYD009, HYD012

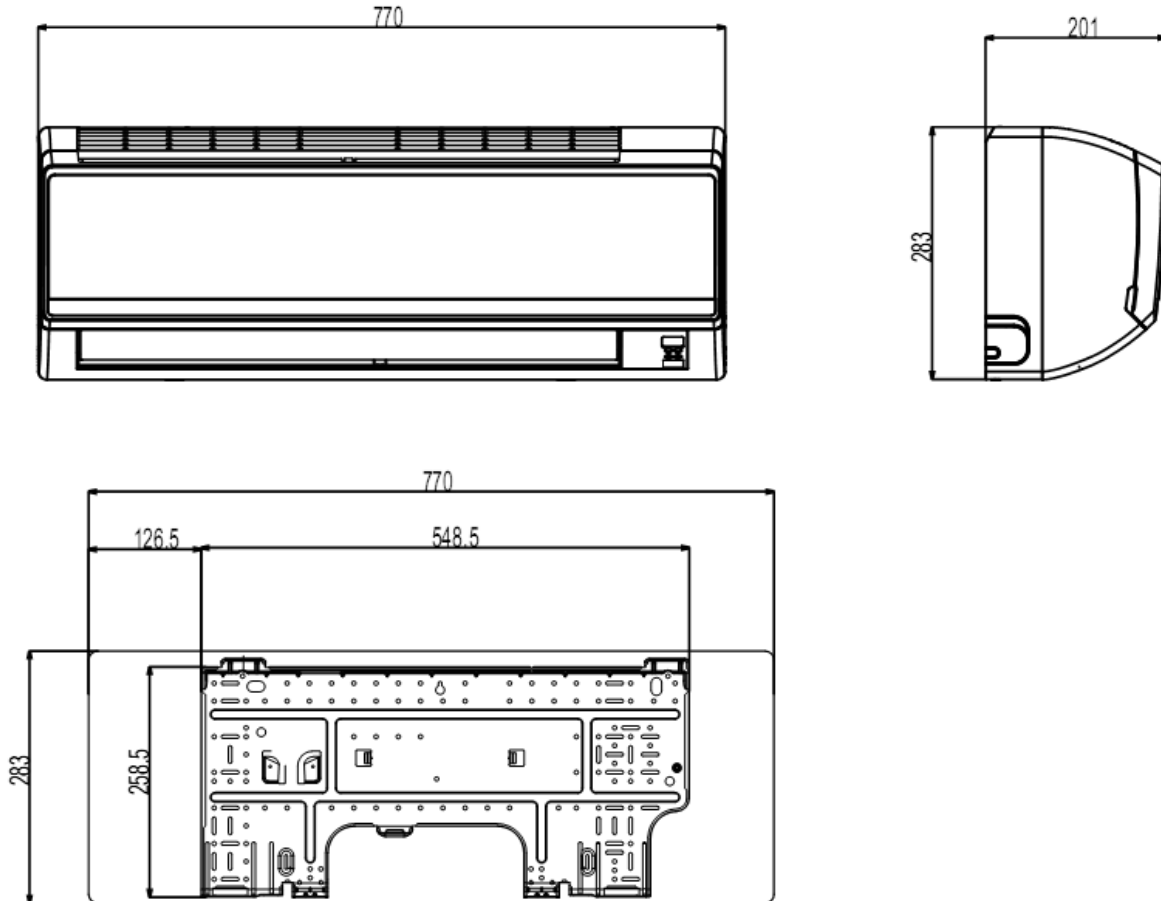

4.2 Indoor: HZD018, HYD018

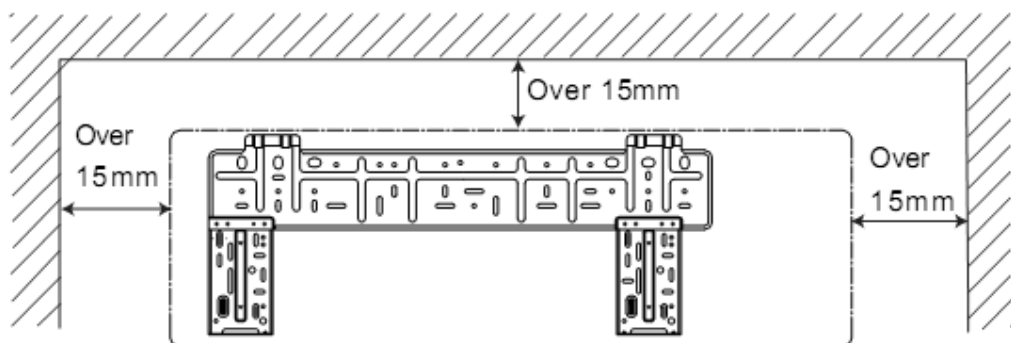
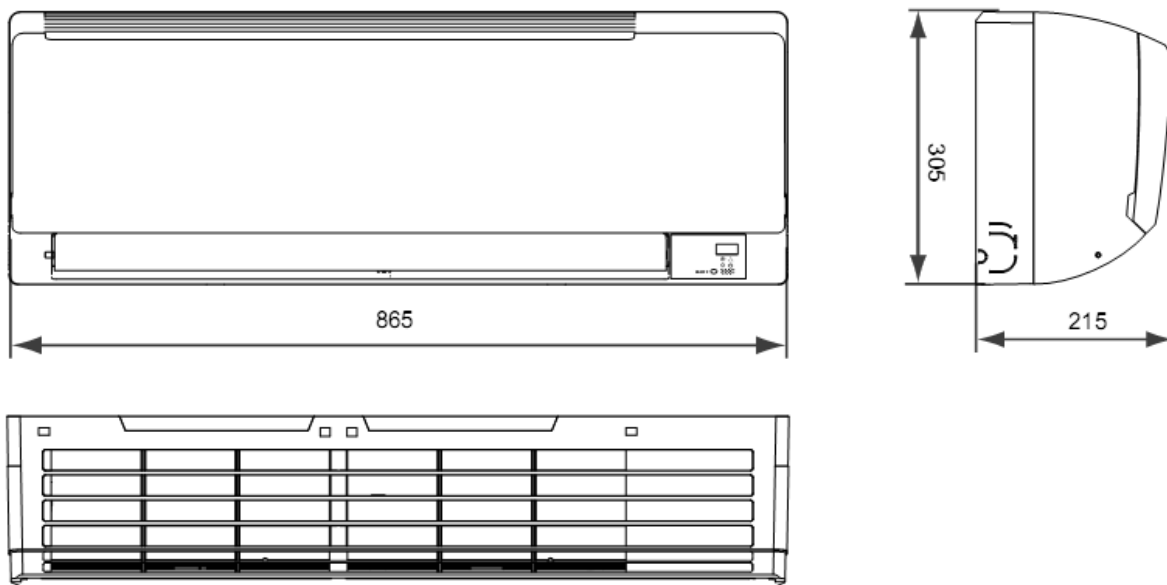

18K Wall Mounting Frame

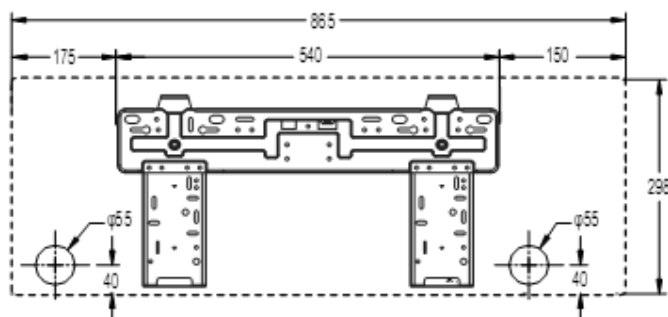

4.3 Outdoor: YBZ214

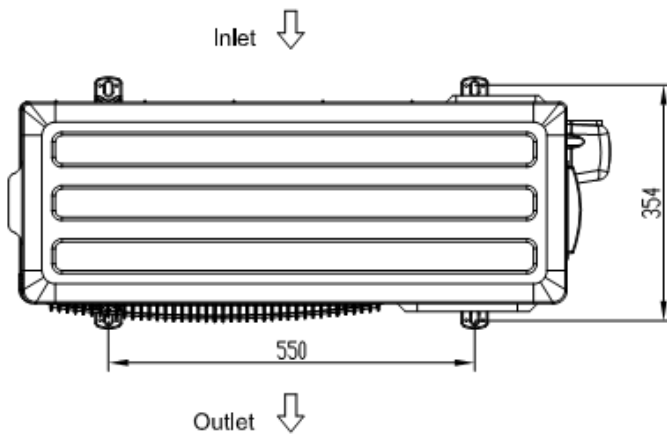
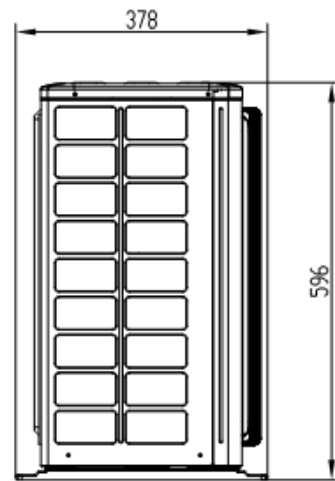
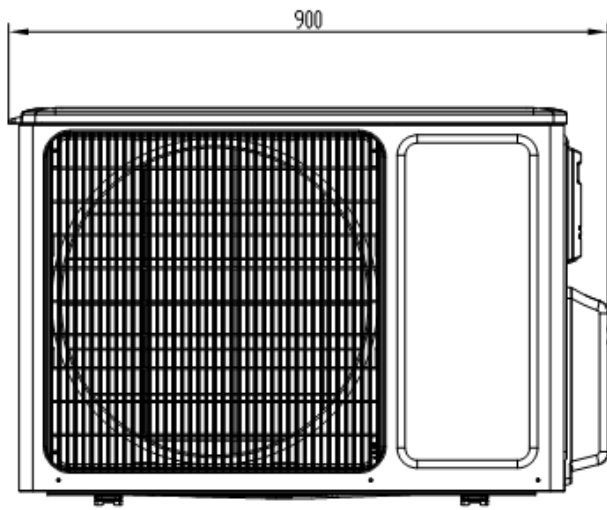

4.4 Outdoor: YBZ318, YBZ430

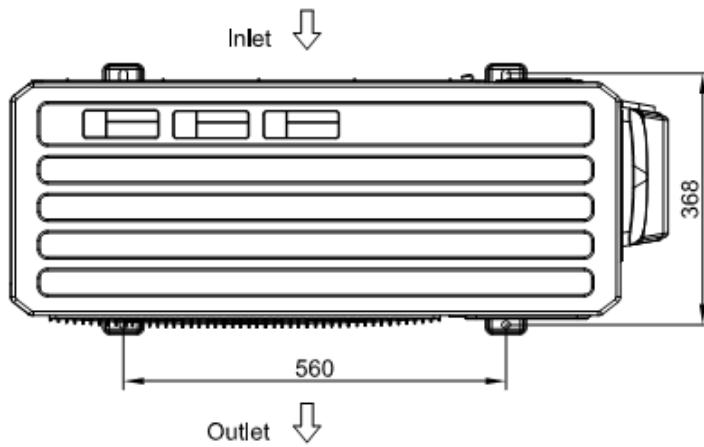
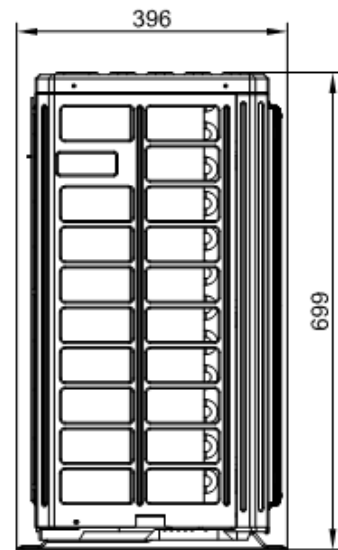
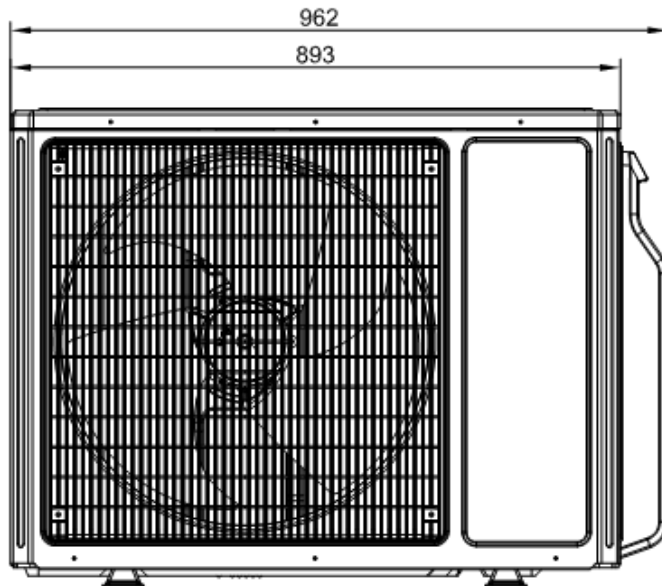

5. PERFORMANCE DATA

5.1 YBZ214

5.1.1 Cooling Capacity (kW)

OD COIL ENTERING AIR DB TEMPERATURE [C°]	DATA	ID COIL ENTERING AIR DB/WB TEMPERATURE [C°]				
		22/15	24/17	27/19	29/21	32/23
-10 - 20 (protection range)	TC	80 - 110 % of nominal				
	SC	80 - 105 % of nominal				
	PI	25 - 50 % of nominal				
25	TC	4.18	4.43	4.67	4.92	5.16
	SC	3.63	3.72	3.80	3.89	3.98
	PI	0.90	0.91	0.93	0.95	0.97
30	TC	3.80	4.04	4.29	4.53	4.77
	SC	3.44	3.53	3.62	3.70	3.79
	PI	1.00	1.02	1.04	1.05	1.07
35	TC	3.41	3.66	3.90	4.14	4.39
	SC	3.26	3.35	3.43	3.52	3.60
	PI	1.10	1.12	1.14	1.16	1.18
40(Protection Range)	TC	80%-92% of nominal				
	SC	80%-92% of nominal				
	PI	80%-92% of nominal				
46(Protection Range)	TC	70%-85% of nominal				
	SC	70%-85% of nominal				
	PI	90%-100% of nominal				

LEGEND

- TC – Total Cooling Capacity, kW
- SC – Sensible Capacity, kW
- PI – Power Input, kW
- WB – Wet Bulb Temp., (°C)
- DB – Dry Bulb Temp., (°C)
- ID – Indoor
- OU – Outdoor

5.1.2 Capacity Correction Factors

Cooling Capacity Ratio Vs. Outdoor Temperature

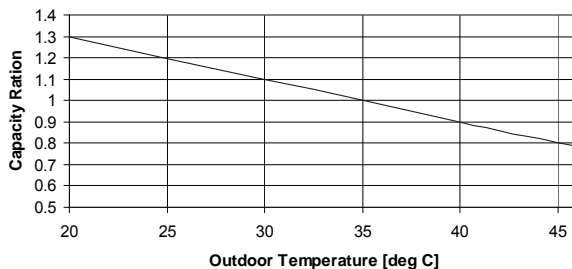

5.1.3 Heating Capacity (kW)

OD COIL ENTERING AIR DB/WB TEMPERATURE [C°]	DATA	ID COIL ENTERING AIR DB TEMPERATURE [C°]		
		15	20	25
-15/-16	TC	2.29	2.15	2.01
	PI	0.72	0.83	0.93
-10/-12	TC	2.74	2.60	2.46
	PI	0.83	0.94	1.04
-7/-8	TC	3.08	2.94	2.80
	PI	0.92	1.02	1.12
-1/-2	TC	3.26	3.11	2.97
	PI	0.96	1.06	1.17
2/1	TC	3.37	3.23	3.08
	PI	0.98	1.09	1.19
7/6	TC	4.44	4.30	4.16
	PI	1.03	1.13	1.23
10/9	TC	4.62	4.48	4.33
	PI	1.07	1.18	1.28
15/12	TC	4.80	4.65	4.51
	PI	1.12	1.23	1.33
15-24 (Protection Range)	TC	85 - 105 % of nominal		
	PI	80 - 120 % of nominal		

LEGEND

- TH – Total Heating Capacity, kW
- PI – Power Input, kW
- WB – Wet Bulb Temp., (°C)
- DB – Dry Bulb Temp., (°C)
- ID – Indoor
- OU – Outdoor

5.1.4 Capacity Correction Factors

Heating Capacity Ratio Vs. Outdoor Temperature

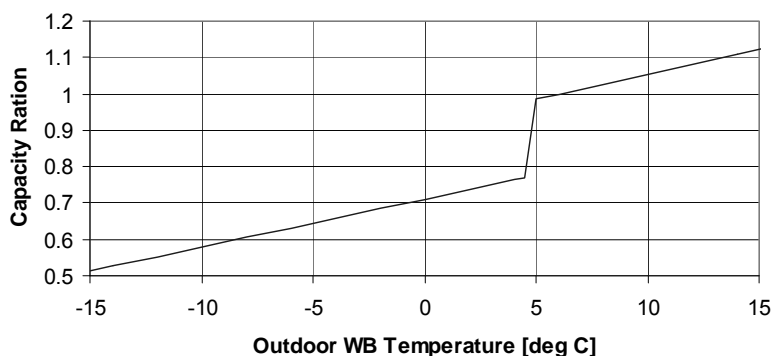

5.2 YBZ318

5.2.1 Cooling Capacity (kW)

OD COIL ENTERING AIR DB TEMPERATURE [C°]	DATA	ID COIL ENTERING AIR DB/WB TEMPERATURE [C°]				
		22/15	24/17	27/19	29/21	32/23
-10 - 20 (protection range)	TC	80 - 110 % of nominal				
	SC	80 - 105 % of nominal				
	PI	25 - 50 % of nominal				
25	TC	7.30	7.72	8.15	8.57	9.00
	SC	6.33	6.48	6.63	6.78	6.93
	PI	1.66	1.69	1.73	1.76	1.79
30	TC	6.62	7.05	7.47	7.90	8.32
	SC	6.01	6.16	6.31	6.46	6.61
	PI	1.85	1.88	1.92	1.95	1.99
35	TC	5.95	6.37	6.80	7.23	7.65
	SC	5.68	5.83	5.98	6.13	6.29
	PI	2.04	2.08	2.11	2.14	2.18
40(Protection Range)	TC	80%-92% of nominal				
	SC	80%-92% of nominal				
	PI	80%-92% of nominal				
46(Protection Range)	TC	70%-85% of nominal				
	SC	70%-85% of nominal				
	PI	90%-100% of nominal				

LEGEND

- TH – Total Heating Capacity, kW
- PI – Power Input, kW
- WB – Wet Bulb Temp., (°C)
- DB – Dry Bulb Temp., (°C)
- ID – Indoor
- OU – Outdoor

5.2.2 Capacity Correction Factors

Cooling Capacity Ratio Vs. Outdoor Temperature

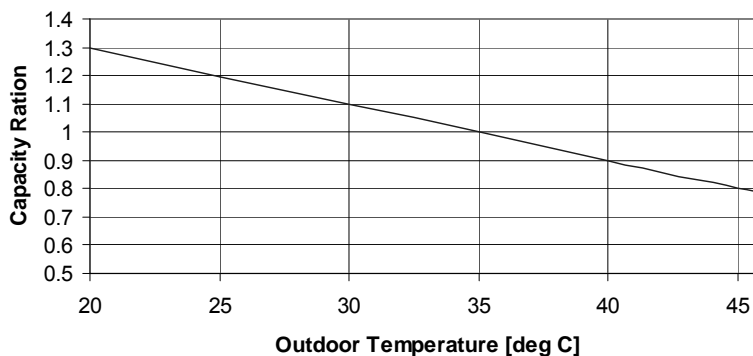

5.2.3 Heating Capacity (kW)

OD COIL ENTERING AIR DB/WB TEMPERATURE [C°]	DATA	ID COIL ENTERING AIR DB TEMPERATURE [C°]		
		15	20	25
-15/-16	TC	4.26	4.00	3.73
	PI	1.41	1.62	1.82
-10/-12	TC	5.11	4.84	4.58
	PI	1.63	1.83	2.04
-7/-8	TC	5.74	5.48	5.21
	PI	1.79	1.99	2.20
-1/-2	TC	6.06	5.79	5.53
	PI	1.87	2.08	2.28
2/1	TC	6.27	6.00	5.74
	PI	1.93	2.13	2.33
7/6	TC	8.26	8.00	7.74
	PI	2.01	2.21	2.41
10/9	TC	8.59	8.33	8.06
	PI	2.10	2.30	2.51
15/12	TC	8.92	8.66	8.39
	PI	2.19	2.40	2.60
15-24 (Protection Range)	TC	85 - 105 % of nominal		
	PI	80 - 120 % of nominal		

LEGEND

- TH – Total Heating Capacity, kW
- PI – Power Input, kW
- WB – Wet Bulb Temp., (°C)
- DB – Dry Bulb Temp., (°C)
- ID – Indoor
- OU – Outdoor

5.1.5 Capacity Correction Factors

Heating Capacity Ratio Vs. Outdoor Temperature

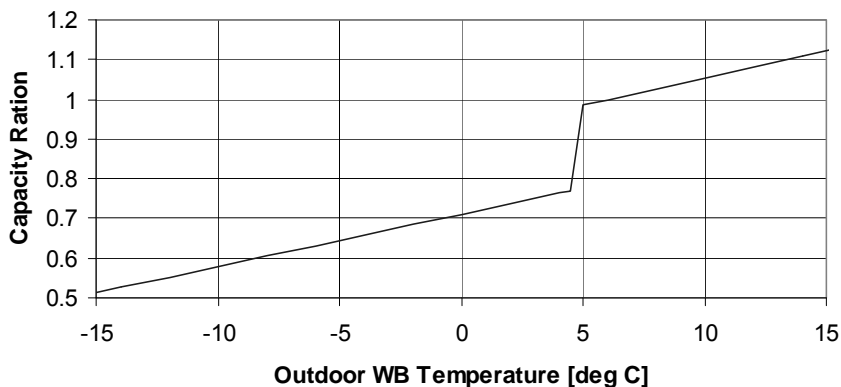

5.3 YBZ430

5.3.1 Cooling Capacity (kW)

OD COIL ENTERING AIR DB TEMPERATURE [C°]	DATA	ID COIL ENTERING AIR DB/WB TEMPERATURE [C°]				
		22/15	24/17	27/19	29/21	32/23
-10 - 20 (protection range)	TC	80 - 110 % of nominal				
	SC	80 - 105 % of nominal				
	PI	25 - 50 % of nominal				
25	TC	8.37	8.86	9.34	9.83	10.32
	SC	7.26	7.43	7.61	7.78	7.95
	PI	1.91	1.95	1.99	2.03	2.07
30	TC	7.60	8.08	8.57	9.06	9.55
	SC	6.89	7.06	7.23	7.41	7.58
	PI	2.13	2.17	2.21	2.25	2.29
35	TC	6.82	7.31	7.80	8.29	8.78
	SC	6.52	6.69	6.86	7.04	7.21
	PI	2.35	2.39	2.43	2.47	2.51
40(Protection Range)	TC	80%-92% of nominal				
	SC	80%-92% of nominal				
	PI	80%-92% of nominal				
46(Protection Range)	TC	70%-85% of nominal				
	SC	70%-85% of nominal				
	PI	90%-100% of nominal				

LEGEND

- TH – Total Heating Capacity, kW
- PI – Power Input, kW
- WB – Wet Bulb Temp., (°C)
- DB – Dry Bulb Temp., (°C)
- ID – Indoor
- OU – Outdoor

5.3.2 Capacity Correction Factors

Cooling Capacity Ratio Vs. Outdoor Temperature

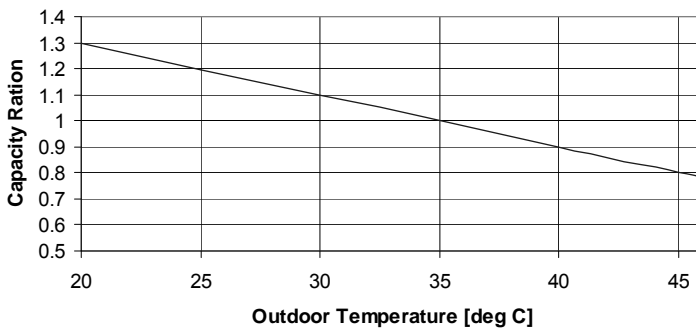

5.3.3 Heating Capacity (kW)

OD COIL ENTERING AIR DB/WB TEMPERATURE [C°]	DATA	ID COIL ENTERING AIR DB TEMPERATURE [C°]		
		15	20	25
-15/-16	TC	4.63	4.35	4.06
	PI	1.54	1.76	1.98
-10/-12	TC	5.55	5.27	4.98
	PI	1.77	1.99	2.21
-7/-8	TC	6.24	5.95	5.67
	PI	1.94	2.17	2.39
-1/-2	TC	6.59	6.30	6.01
	PI	2.03	2.25	2.47
2/1	TC	6.82	6.53	6.24
	PI	2.09	2.31	2.53
7/6	TC	8.99	8.70	8.41
	PI	2.18	2.40	2.62
10/9	TC	9.34	9.06	8.77
	PI	2.28	2.50	2.72
15/12	TC	9.70	9.42	9.13
	PI	2.38	2.60	2.82
15-24 (Protection Range)	TC	85 - 105 % of nominal		
	PI	80 - 120 % of nominal		

LEGEND

- TH – Total Heating Capacity, kW
- PI – Power Input, kW
- WB – Wet Bulb Temp., (°C)
- DB – Dry Bulb Temp., (°C)
- ID – Indoor
- OU – Outdoor

5.3.4 Capacity Correction Factors

Heating Capacity Ratio Vs. Outdoor Temperature

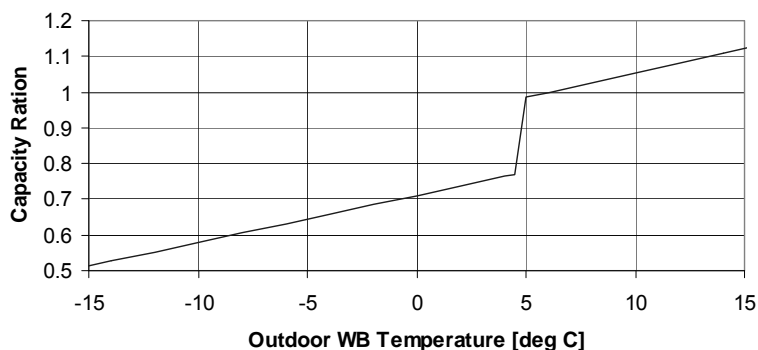

6. PRESSURE CURVES

6.1 Model: YBZ214

6.1.1 Cooling

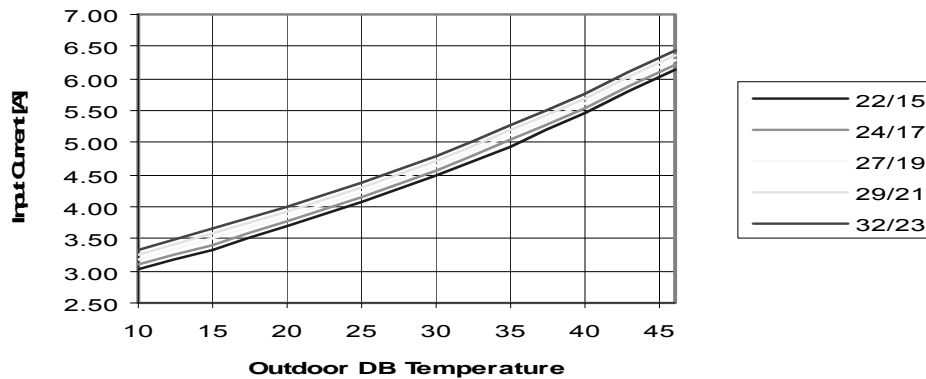
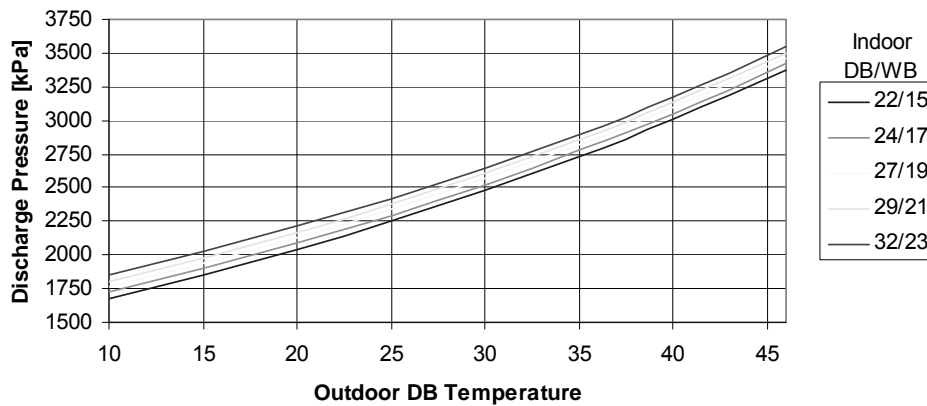
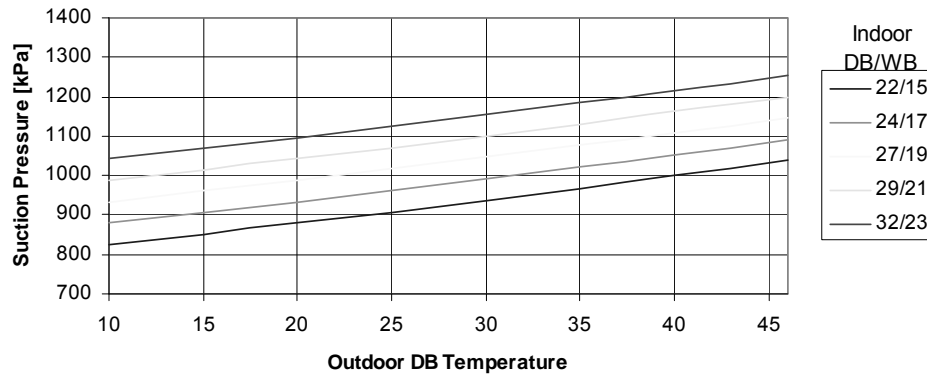

6.1.2 Heating

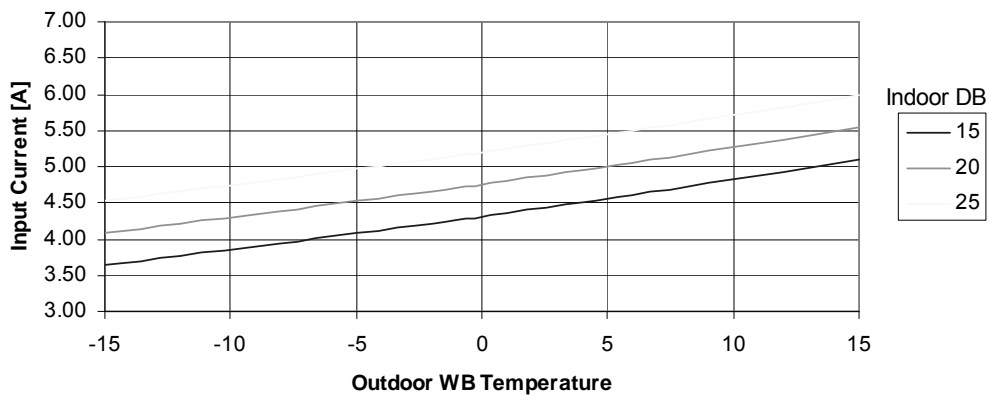
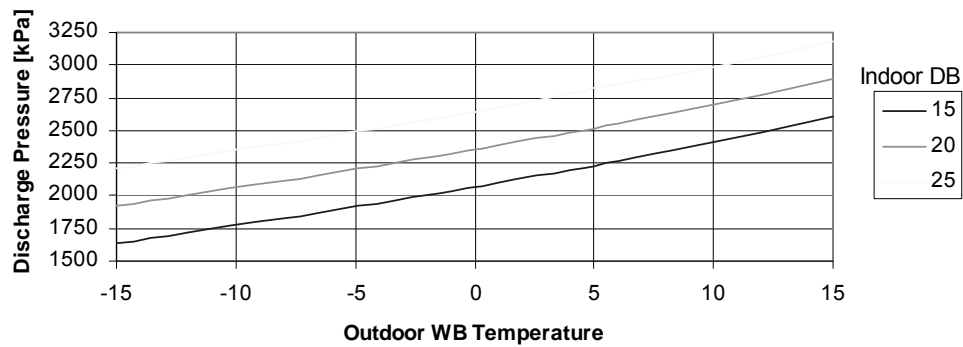
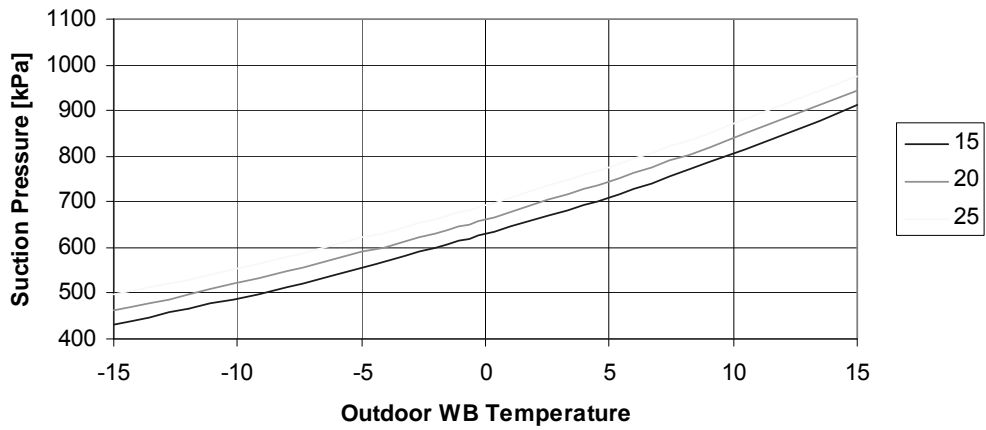

6.2 Model: YBZ318

6.2.1 Cooling

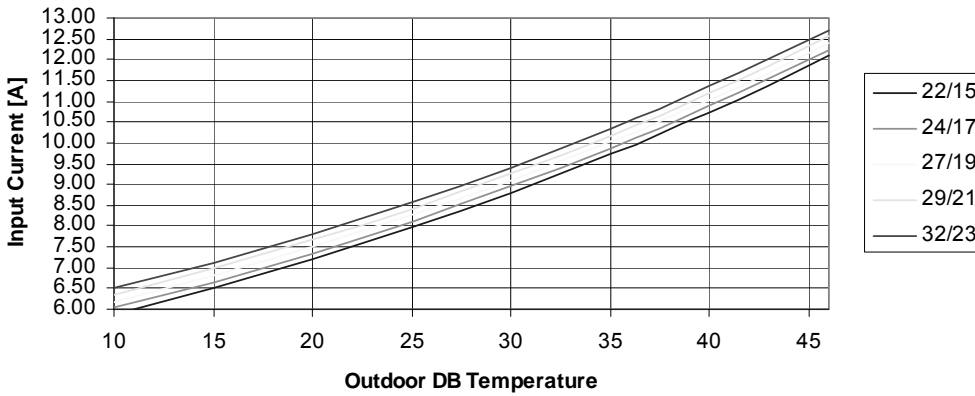
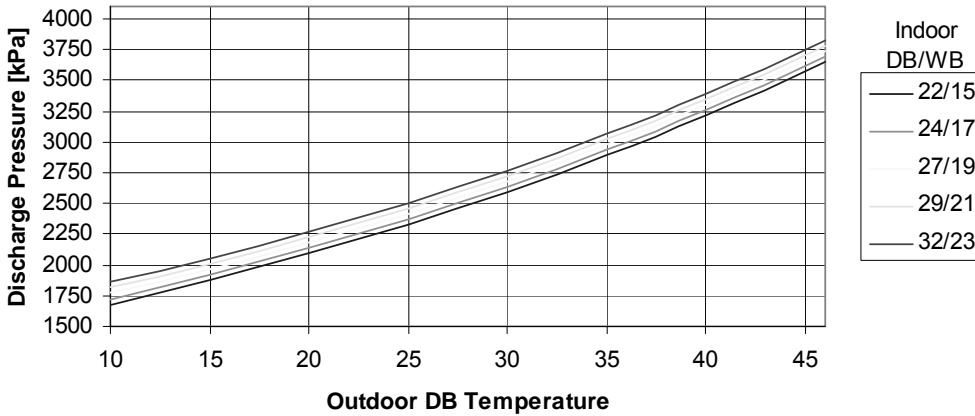
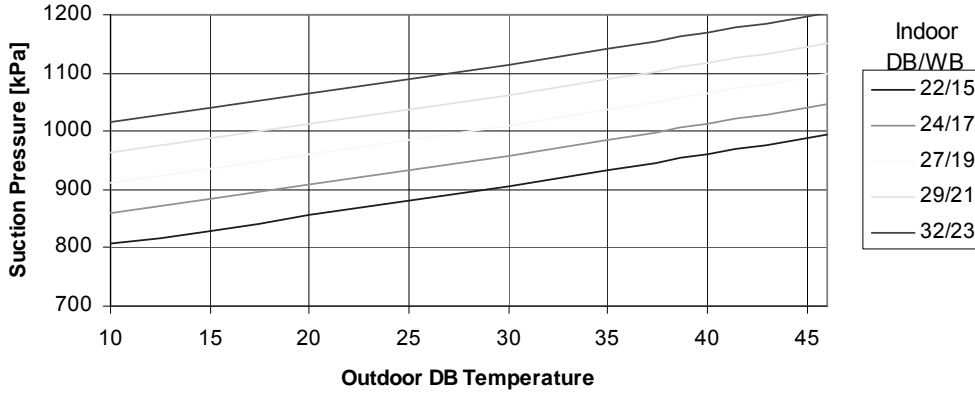

6.2.2 Heating

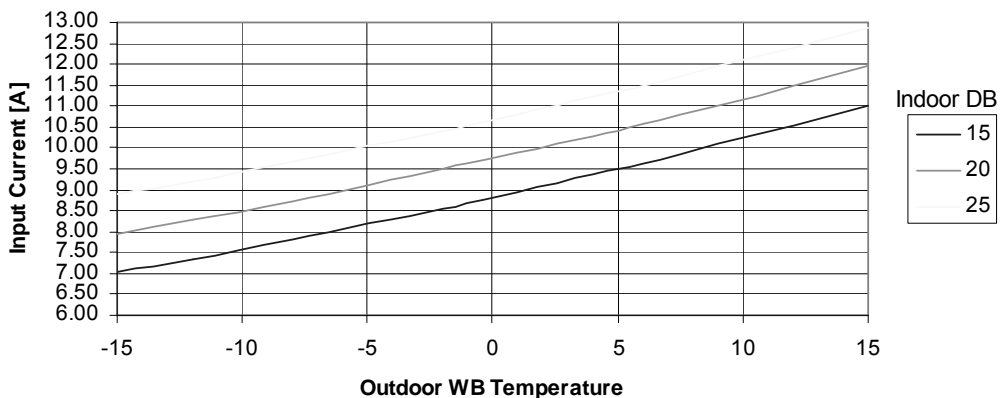
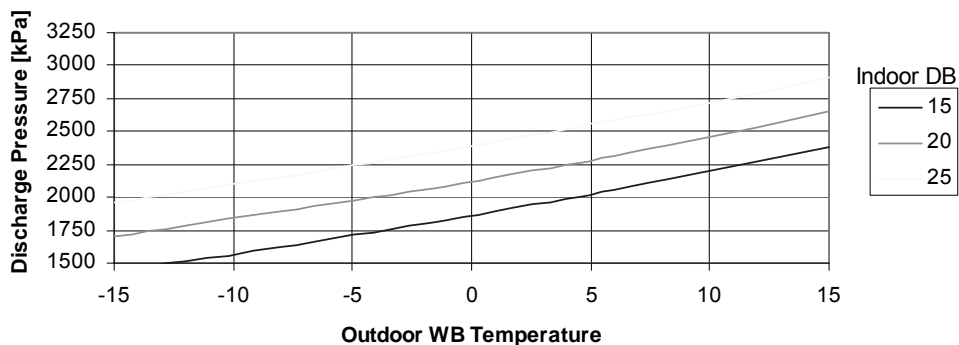
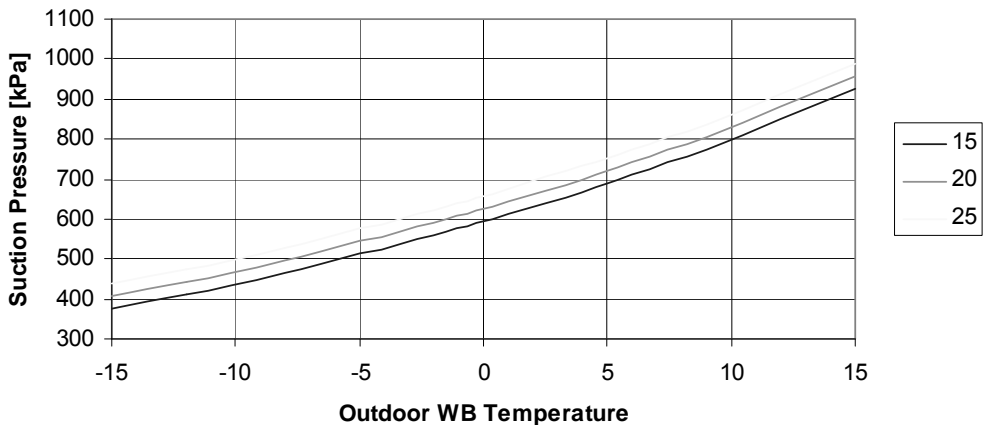

6.3 Model: YBZ430

6.3.1 Cooling

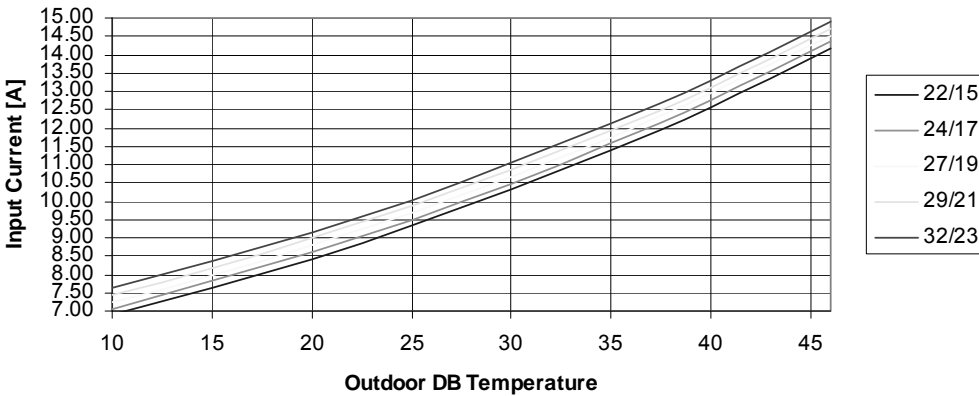
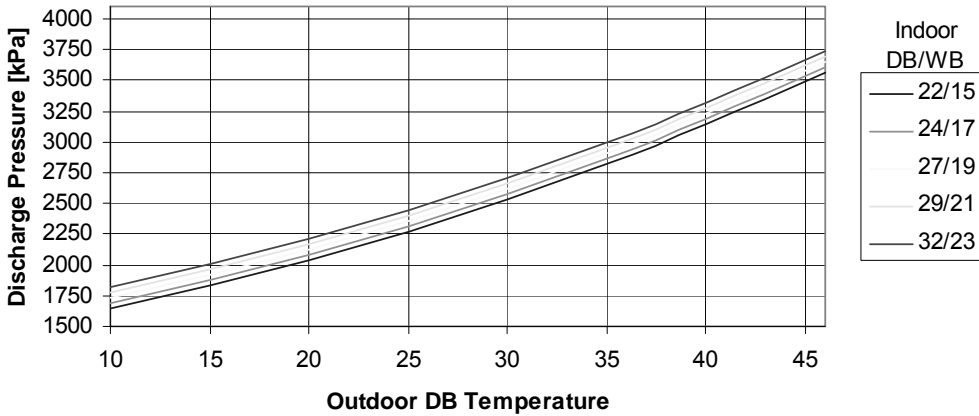
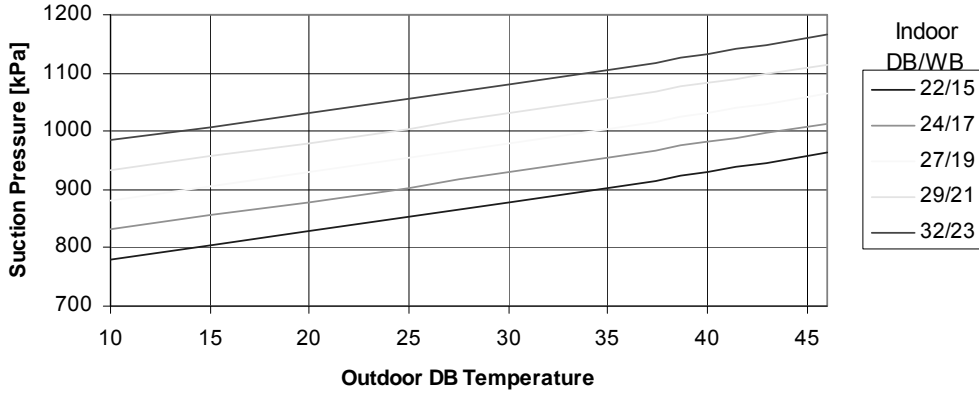

6.3.2 Heating

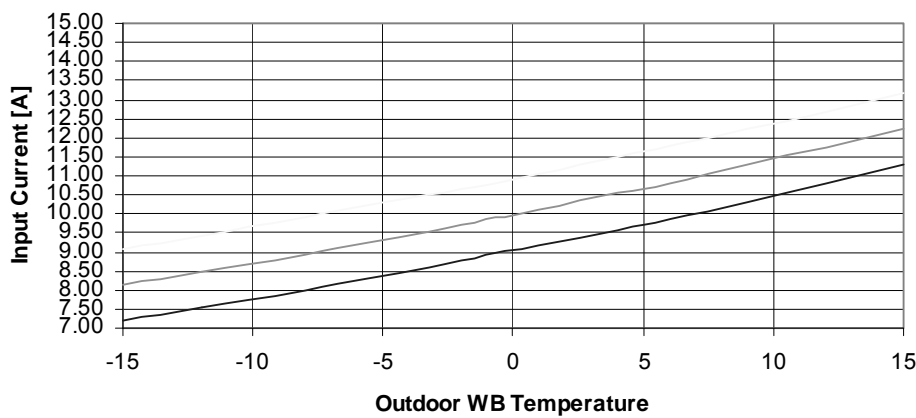
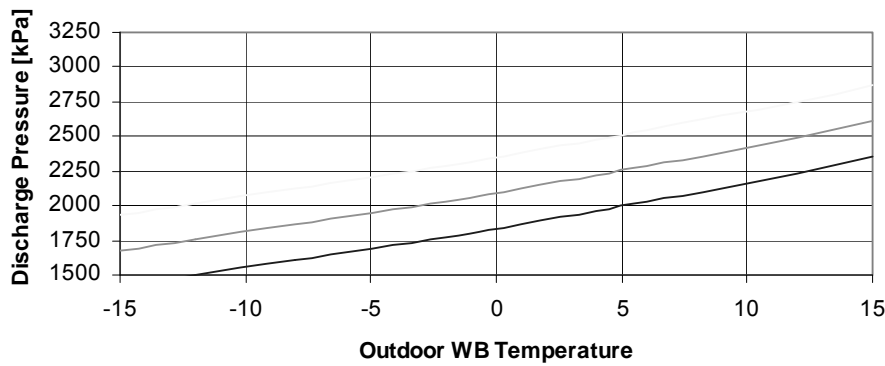
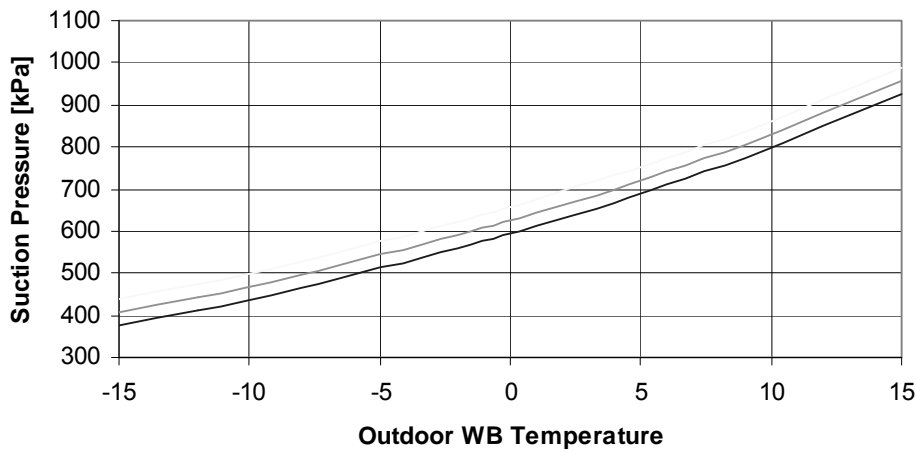

7. SOUND LEVEL CHARACTERISTICS

7.1 Sound Pressure Level

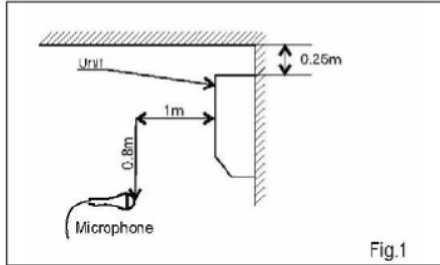

Figure 1. Wall Mounted

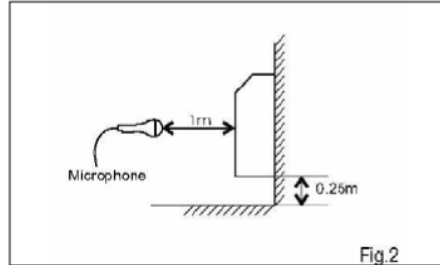

Figure 2. Floor Mounted

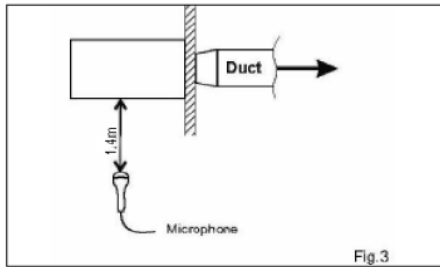

Figure 3. Ducted

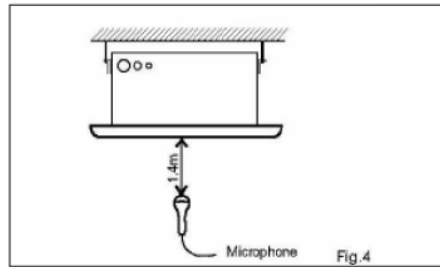
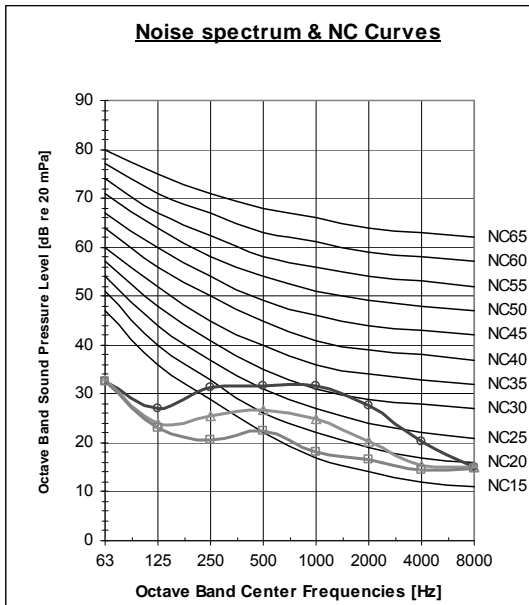

Figure 4. Cassette

7.2 Sound Pressure Level Spectrum (Measured as Figure 1)

HZD009, HYD009 Cooling



HZD009, HYD009 Heating

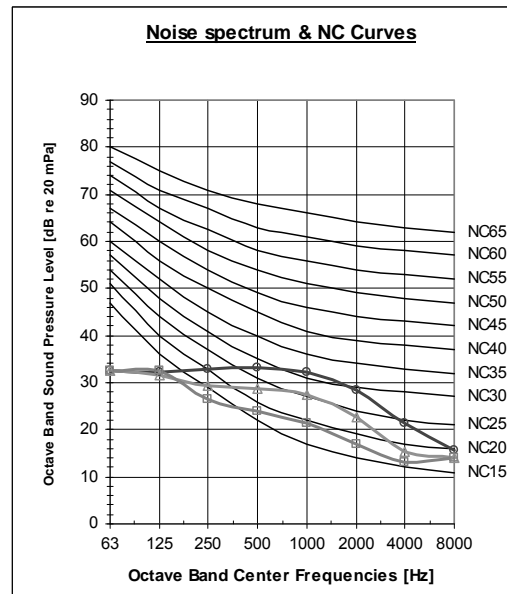

FAN SPEED	LINE
HI	—○—
ME	—△—
LO	—□—

HZD012, HYD012 Cooling

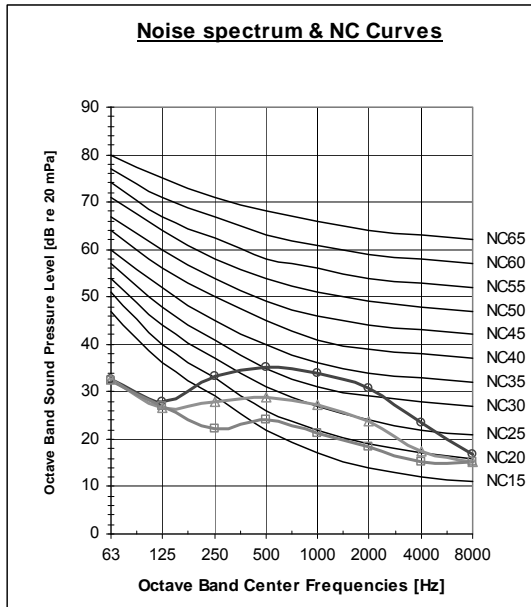

HZD012, HYD012 Heating

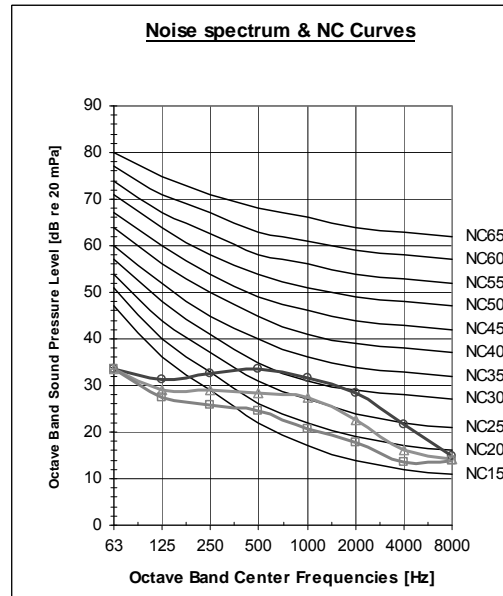

FAN SPEED	LINE
HI	—○—
ME	—△—
LO	—□—

HZD018, HYD018 Cooling

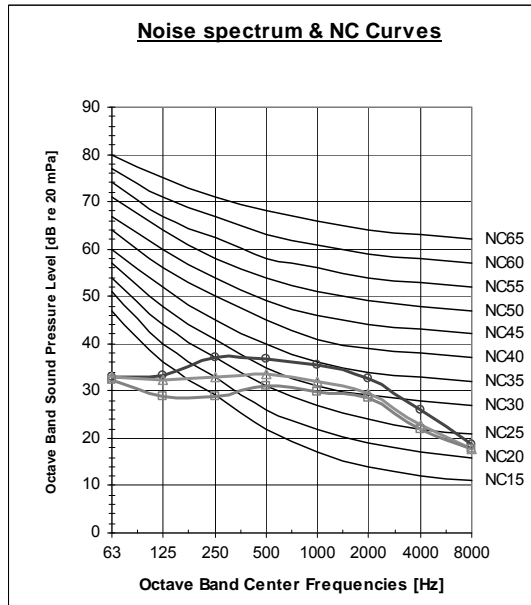

HZD018, HYD018 Heating

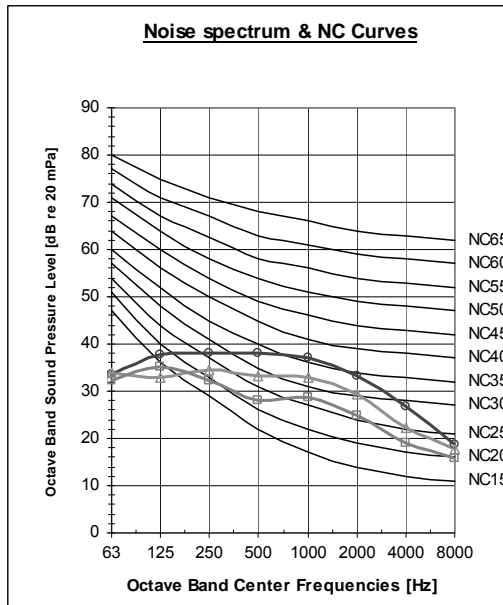

FAN SPEED	LINE
HI	—○—
ME	—△—
LO	—□—

8. ELECTRICAL DATA

MODEL	YBZ214	YBZ318	YBZ430
Power Supply	To outdoor 1PH-220-240V-50Hz		
Max Current, A	15A	21A	21A
Circuit Breaker, A	25A	32A	32A
Power Supply Wiring No. X Cross Section mm ²	3x2.5 mm ²	3x4.0mm ²	3x4.0mm ²
Interconnecting Cable Model No. X Cross Section mm ²	4x1.0 mm ²	4x1.0 mm ²	4x1.0 mm ²

NOTE

Power wiring cord should comply with local laws and electrical regulations requirements.

9. WIRING DIAGRAM

9.1 HZD009, HZD012, HYD009, HYD012

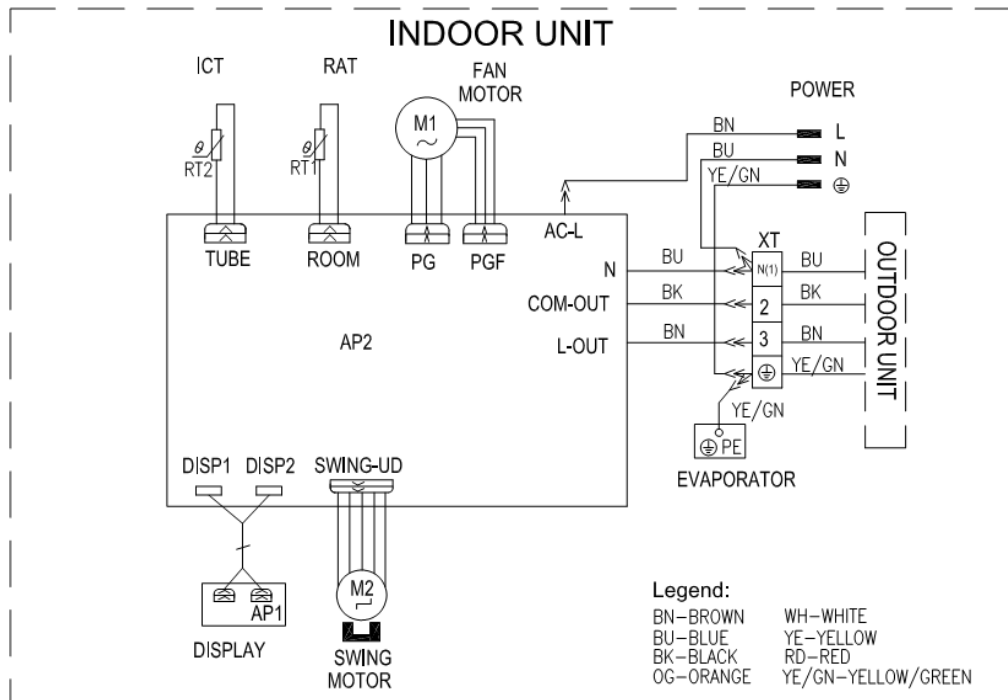

9.2 HZD018, HYD018

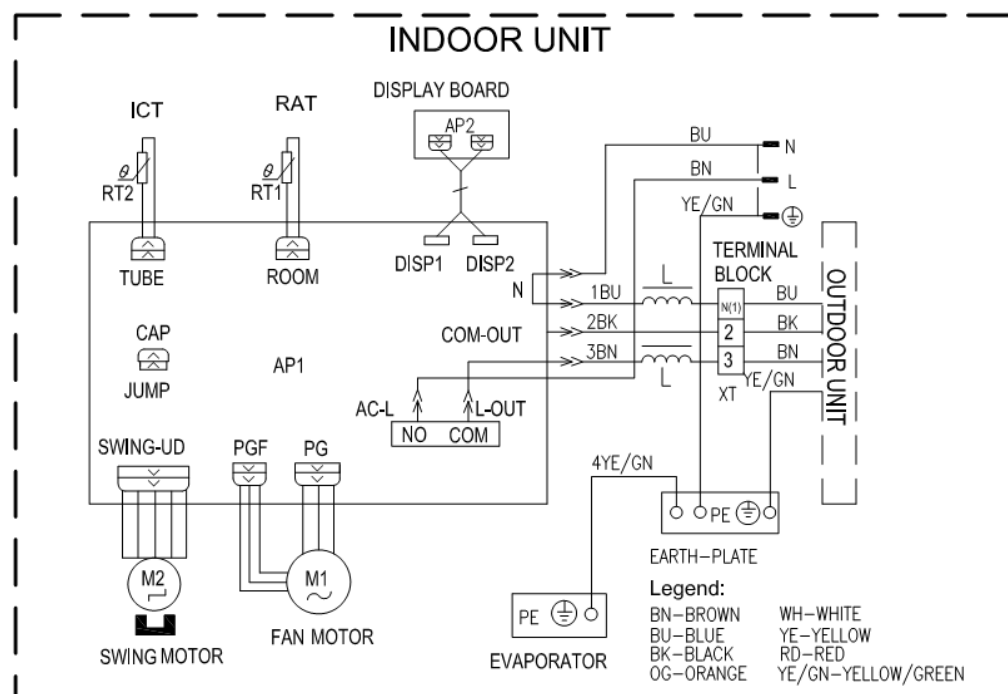

9.3 YAZ214

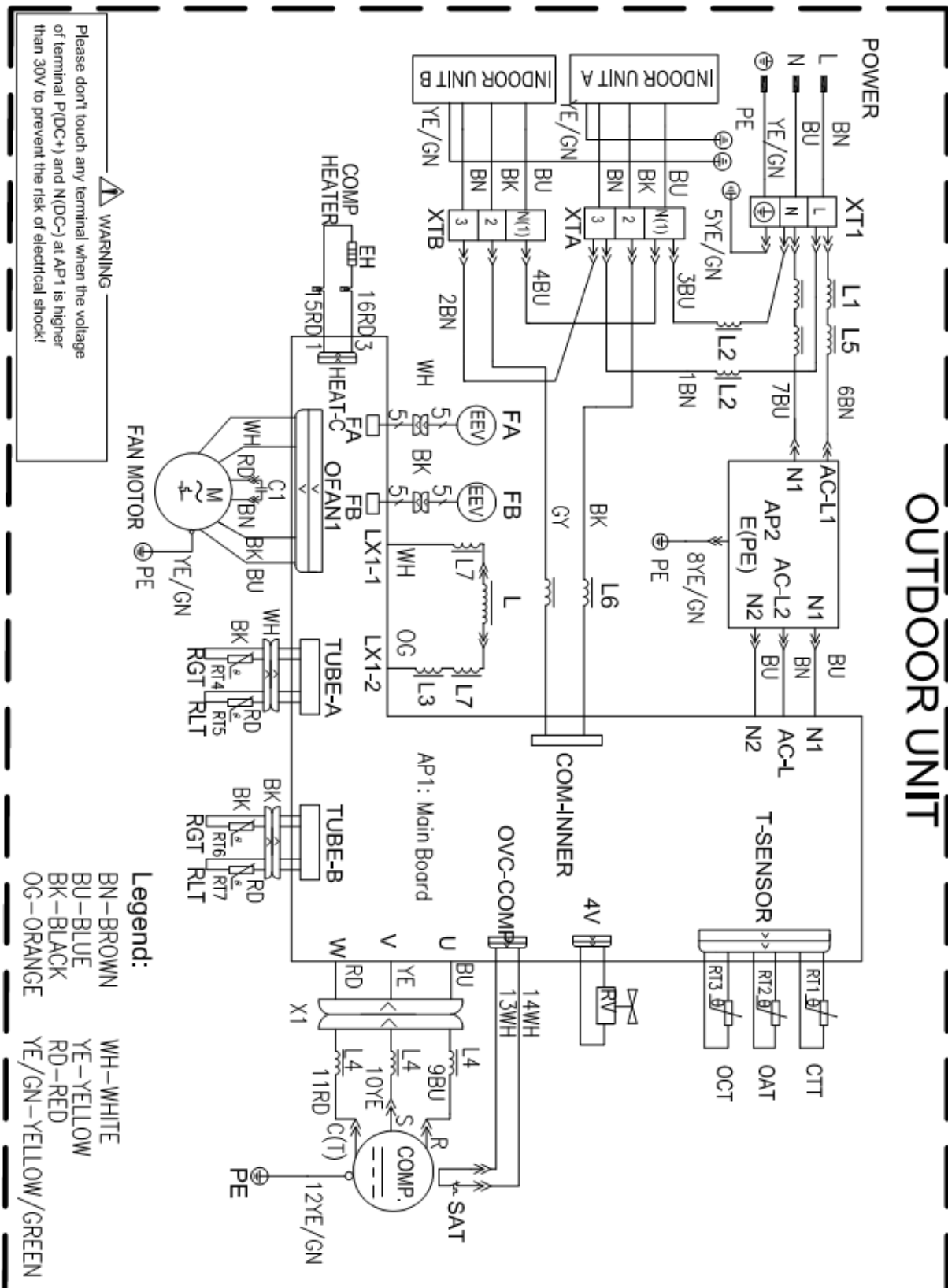

OUTDOOR UNIT

9.4 YAZ318

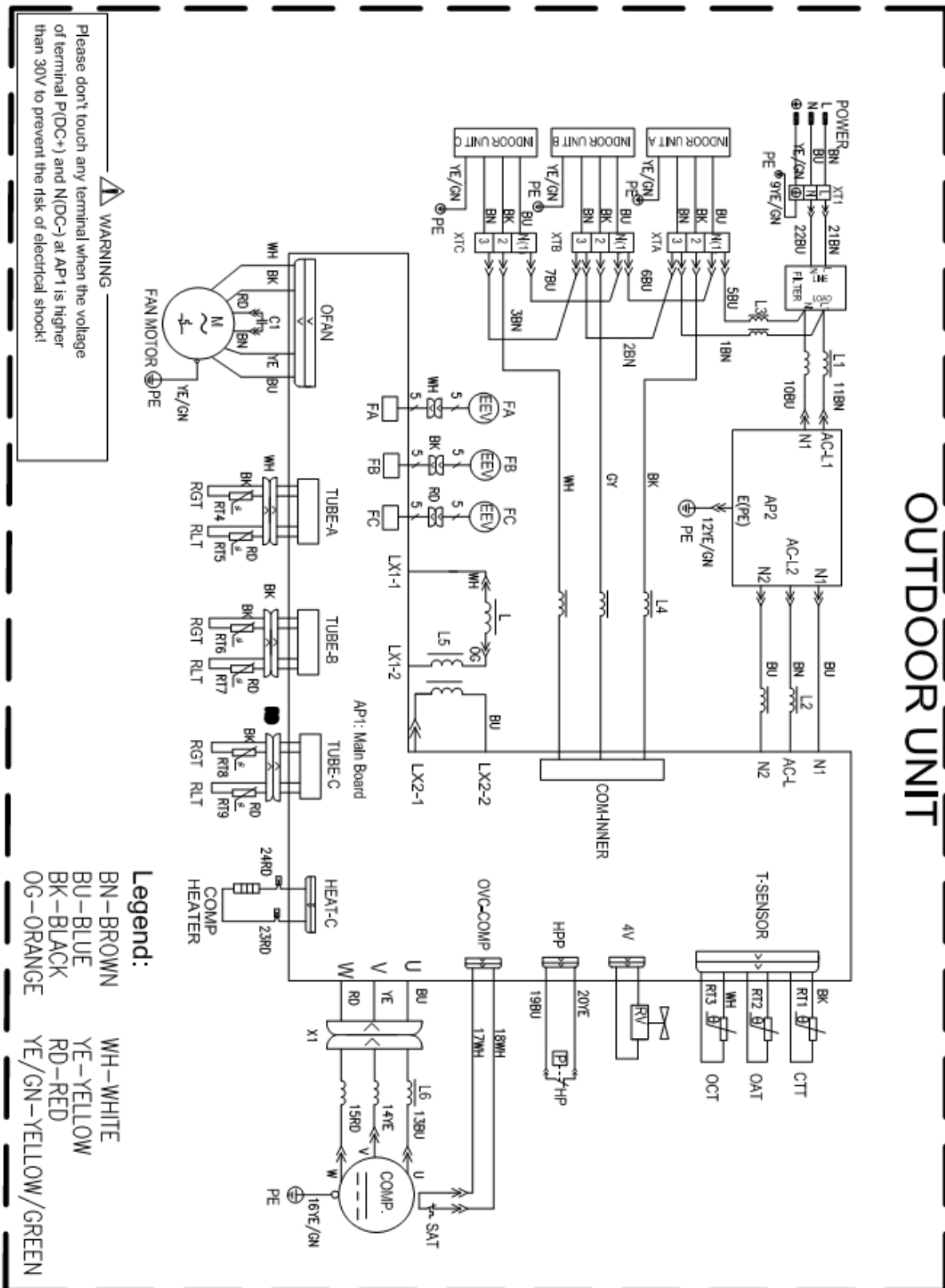

9.5 YAZ430

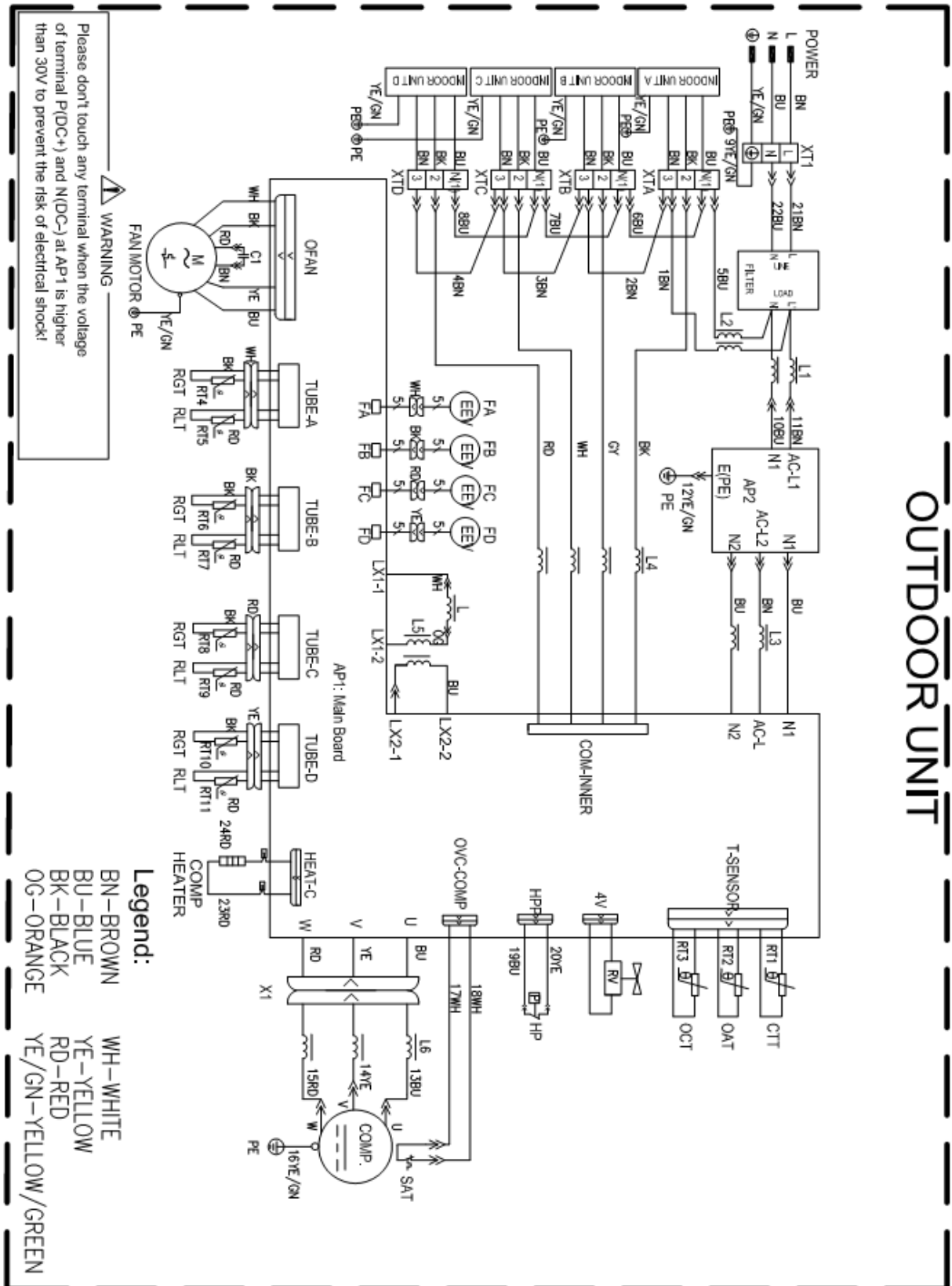

9.6 Wiring connection between IDU and ODU

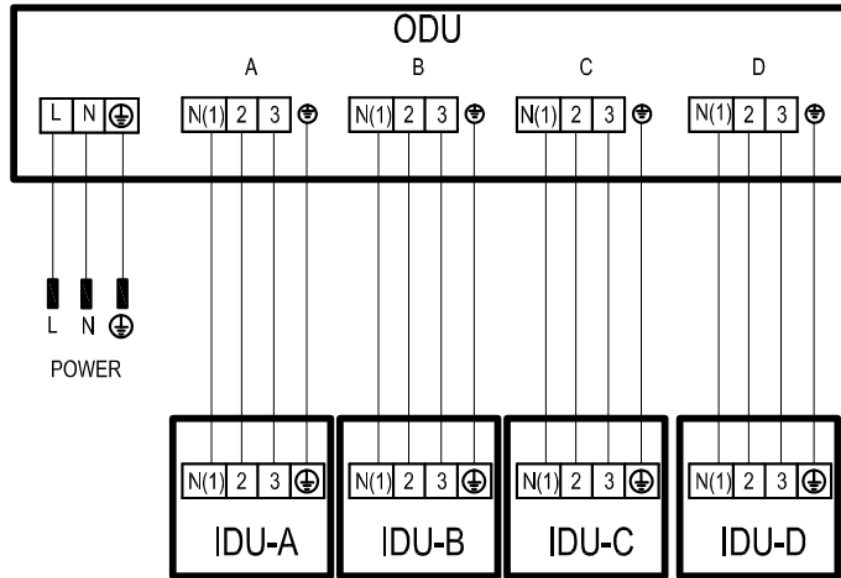

10. REFRIGERATION DIAGRAMS

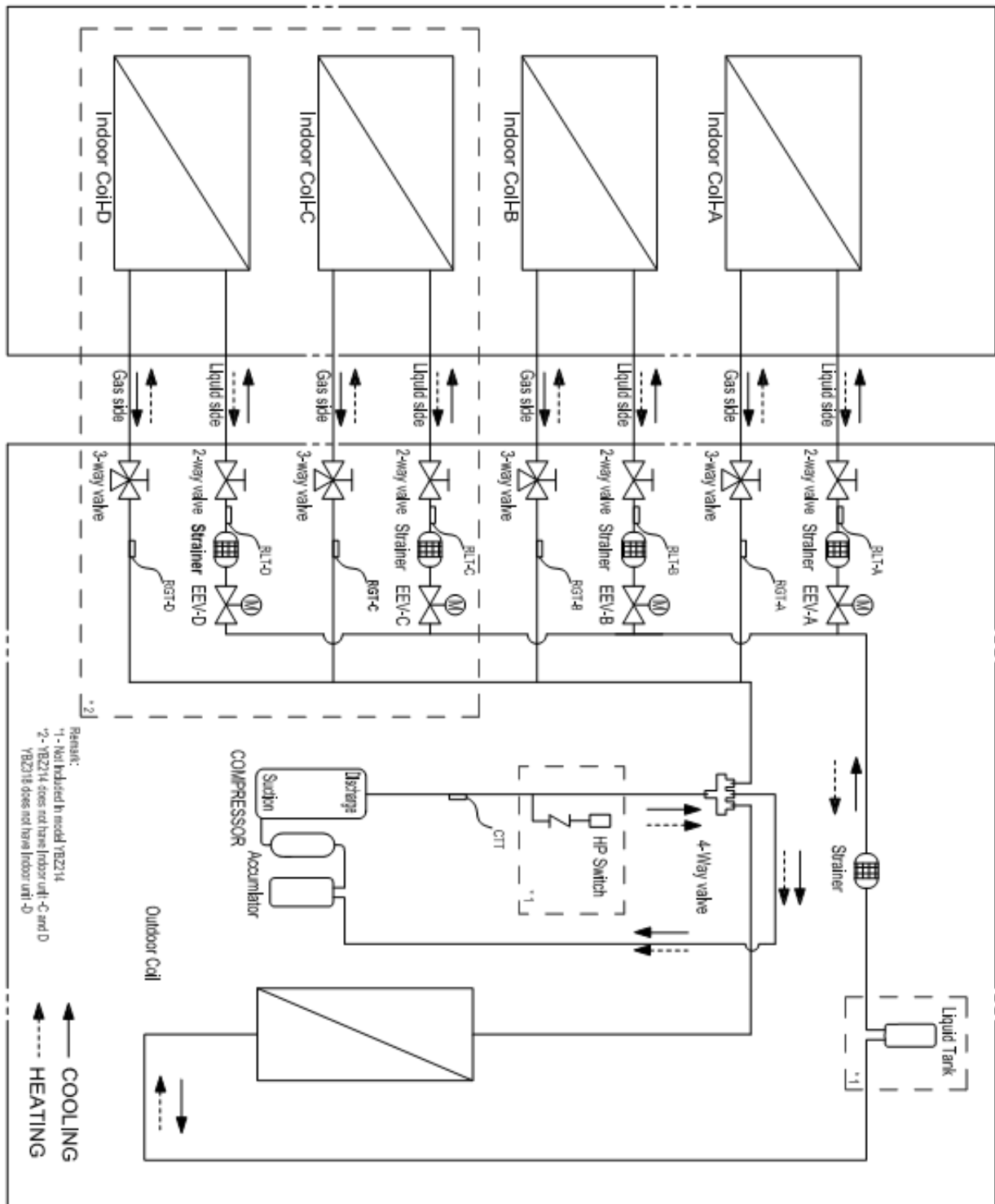

11. TUBING CONNECTIONS

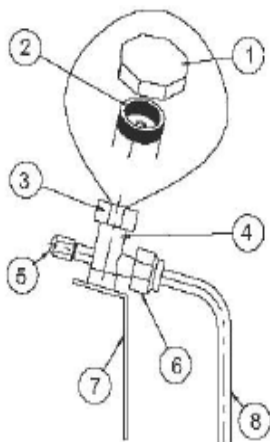
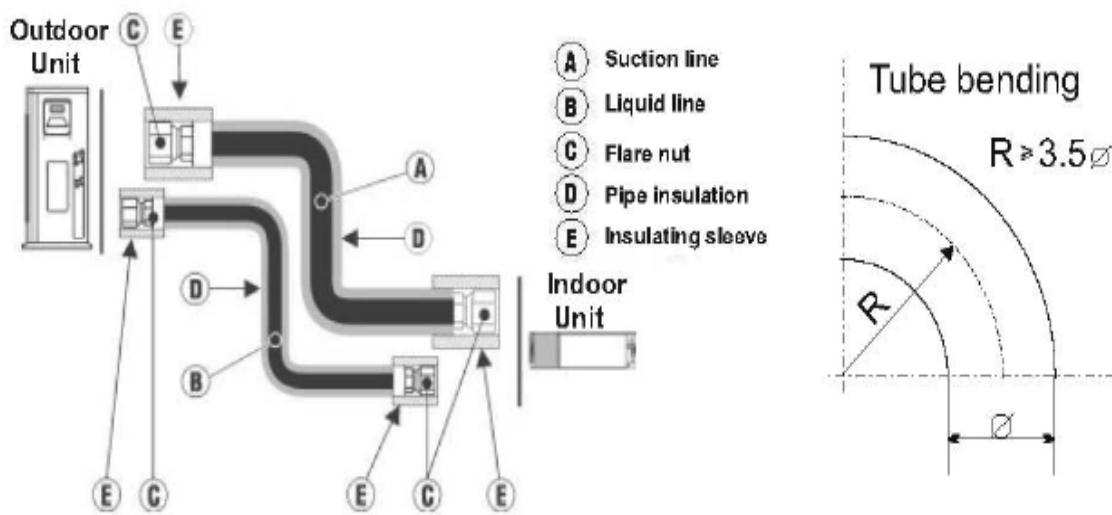

TUBE (Inch)	1/4"	3/8"	1/2"	5/8"	3/4"
TORQUE (Nm)					
Flare Nuts	15-18	40-45	60-65	70-75	80-85
Valve Cap	13-20	13-20	18-25	18-25	40-50
Service Port Cap	11-13	11-13	11-13	11-13	11-13

1. Valve Protection Cap-end
2. Refrigerant Valve Port (use Allen wrench to open/close)
3. Valve Protection Cap
4. Refrigerant Valve
5. Service Port Cap
6. Flare Nut
7. Unit Back Side
8. Copper Tube

12. CONTROL SYSTEM

12.1 Electronic Control

12.1.1 Abbreviations

Abbreviation	Definition
A/C	Air Condition
BMS	Building Management System
PWR	System Power
CTT	Compressor Top Temperature sensor
DCI	DC Inverter
EEV	Electronic Expansion Valve
HE	Heating Element
HMI	Human Machine Interface
HST	Heat Sink Temperature sensor
Hz	Hertz (1/sec) – electrical frequency
ICT	Indoor Coil Temperature (RT2) sensor
IDU	Indoor Unit
MCU	Micro Controller Unit
OAT	Outdoor Air Temperature sensor
OCT	ODU Coil Temperature sensor
ODU	Outdoor Unit
OFAN	Outdoor Fan
PFC	Power Factor Corrector
RAC	Residential A/C
RC	Reverse Cycle (Heat Pump)
RGT	Return Gas Temperature sensor
RPS	Rounds per second (mechanical speed)
RV	Reverse Valve
SB,STBY	Stand By
SUCT	Compressor Suction Temperature sensor
S/W	Software
TBD	To Be Defined
TMR	Timer

12.1.2 Compressor Frequency Control

12.1.2.1 Compressor frequency setting

The Load calculation is done by each indoor unit controller, based on a PI control scheme which is based on the difference between SPT and RAT.

ODU controller will decide the compressor frequency based on the total load from all the indoors.

Compressor frequency will be limited within following ranges:

Mode	Minimum Frequency (MinFreq)			Maximum Frequency (MaxFreq) *		
	YBZ214	YBZ318	YBZ430	YBZ214	YBZ318	YBZ430
Cooling	15	15	15	110	110	110
Heating	15	15	15	110	110	110

* Maximum frequency is also decided by different indoor combinations.

12.1.2.2 Frequency Changes Control

Frequency change rate is 1 Hz/sec.

12.1.2.3 Compressor Starting Control

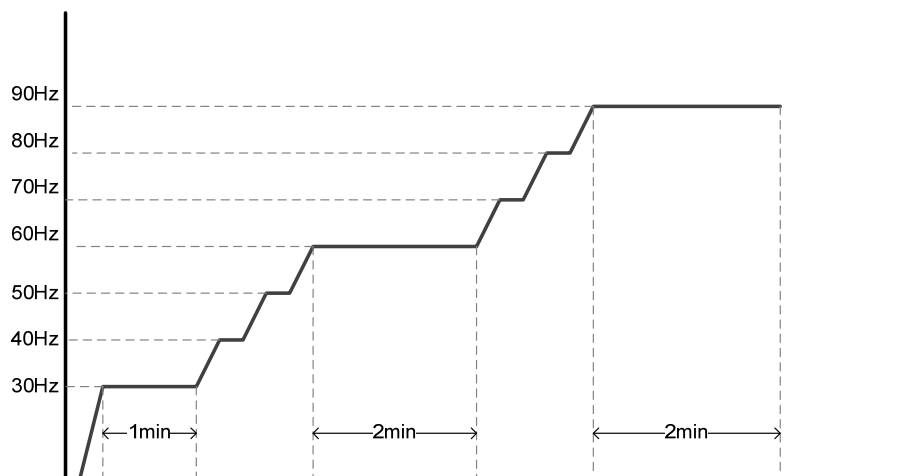

12.1.2.4 Minimum On and Off Time

Prohibit turning ON the compressor for 3 minutes after turning it off. (Except during deicing protection)

Prohibit turning OFF the compressor for 7 minutes after turning it on (except protections required immediate compressor stop)

12.1.3 Indoor Fan Control

8 Indoor fan speeds are determined for each model. 4 speeds for COOL modes and 4 speeds for HEAT mode.

Unit Model	Mode	Turbo(Super high)	High	Medium	Low
09	Cooling	1300	1100	900	700
	Heating	1300	1140	980	820
12	Cooling	1350	1150	950	750
	Heating	1350	1190	1020	850
18	Cooling	1350	1100	950	800
	Heating	1400	1200	1050	900

In high/ medium/ low indoor fan user setting, unit will operate fan in selected speed.

In Auto Fan user setting, fan speed will be adjusted automatically according to the difference between actual room temperature (RAT) and user set point temperature (SPT).

Indoor Fan speed		High	Medium	Low
RAT-SPT	Cooling	≥ 2	(0,2)	≤ 0
	Heating	≤ 1	(1,3)	≥ 3

During Auto Fan operating, one speed should keep at least 210sec operating before switching to other speeds.

In DRY mode, the automatic fan speed is forced to be low.

12.1.3.1 Turbo Speed

In COOL and HEAT mode (not available in AUTO, DRY, FAN mode), press the Turbo button, the super high fan speed is selected on Remote control and the indoor fan rotates at super high speed.

12.1.4 Outdoor Fan Control

The outdoor fan motor is a 3 speed AC motor and controlled by the relays on outdoor controller. OFAN speed will be changed according to OAT temperature.

12.1.5 EEV Control

12.1.5.1 EEV homing

When compressor stops or unit is power on, the following is performed immediately:

- All EEV's are closed 520 steps and then set this opening as 0 step.
- Then All EEVs are opened 480 steps and ready for system starting.

12.1.5.2 EEV initial value determination

The EEV initial value (open loop) is determined according to the number of the active indoor units, mode, and the capacity code of the unit.

12.1.5.3 Balance time

During the balance after SB the correction is not calculated. After that the correction value is updated every 5 seconds.

12.1.5.4 EEV corrections

The corrections will keep the compressor in the proper operation temperature (Target CTT control) and will balance between the indoor units by controlling their super heat.

12.1.5.5 EEV opening of inactive indoors

Under Cool Mode/Dry Mode, relative EEV of inactive indoor will be fully closed to 0.

Under Heat Mode, relative EEV of inactive indoor will maintain an opening in a range so that refrigerant and oil can come back to outdoor.

12.1.6 Reversing Valve (RV) Control

Reversing valve is on in heat mode.

Switching of RV state is done only after compressor is OFF for over 2 minutes.

12.2 Fan Mode

In this mode, the indoor fan may run at high, medium, low and automatic speed. The compressor, outdoor fan and 4-way valve will be OFF.

In this mode, the range of setting temperature is 16~30C

12.3 Cool Mode

12.3.1 Starting Cool Mode

If the system is in idle, when any one indoor requests the cooling mode operating, the system will run in Cool Mode. EEV, OFAN and compressor will start operating.

12.3.2 Compressor's action when Indoor changed to inactive (OFF or Thermo OFF)

12.3.2.1 All indoors to inactive

Compressor stops immediately, OFAN stops after 1 min.

12.3.2.2 Partial indoors to inactive

Recalculate the load immediately, for Inactive indoors, EEV opening is set to 0 step.

12.3.3 RV

RV is OFF in Cool Mode.

12.3.4 OFAN control during Cool Mode

OFAN will start 5sec before compressor start. After starting, it will run at High speed for 3 mins, and then switch to the requested speed.

OFAN will run at one speed for at least 80sec, except the condition of the active indoor amount changing.

After compressor stopping, the OFAN will keep the current speed for 1min and then stop.

12.3.5 Oil return operation during Cool Mode**12.3.5.1 Starting oil return**

Oil return operation is to avoid compressor operating with low frequency for long time.

12.3.5.2 Oil return operation

Indoor display shows "H1"

Compressor is forced to run higher frequency.

12.3.5.3 Exiting oil return

The oil return operating time reaches 5min (Including frequency's changing time)

12.3.6 Indoor Fan operation under Cool Mode

In manual fan speed (Turbo/Hi/Med/low) setting, IFAN will operate at the setting speed.

In Auto Fan user setting, fan speed will be adjusted automatically according to the SPT and RAT, refer to 12.1.3

12.4 Heat Mode**12.4.1 Condition of starting Heat Mode**

If the system is in idle, when any one indoor request the heating mode operating, the system will run in Heat Mode. EEV, OFAN and compressor will start operating.

12.4.2 Compressor's action when Indoor changed to inactive (OFF or Thermo OFF)

12.4.2.1 All indoors to inactive

Compressor stops immediately, OFAN stops after 1 min.

12.4.2.2 Partial indoors to inactive

Recalculate the load immediately, for Inactive indoors, EEV opening will follow 12.1.5.5.

12.4.3 OFAN control during Heat Mode

OFAN will start 5sec before compressor starts. After starting, it will run at High speed for 40 sec then switch to the requested speed.

OFAN will run at one speed for at least 80sec.

After compressor stopping, the OFAN will keep the current speed for 1min and then stop.

12.4.4 Oil return operation during Heat Mode**12.4.4.1 Starting oil return**

Oil return operation is to avoid compressor operating with low frequency for long time.

12.4.4.2 Oil return operation

Indoor display shows "H1"

System will run at Cool Mode. Compressor is forced to run higher frequency. And both IFAN and OFAN are stopped.

12.4.4.3 Exiting oil return

The oil return operating time reaches 5min (Including frequency's changing time)

12.4.5 Indoor Fan Control in Heat Mode

Indoor fan speed depends on the indoor coil temperature

Anti-cold air function

When starting the heating mode, anti-cold air function will be activated and indoor fan can run at low speed or stop running. This function will terminate after the unit runs for 3min or the ICT reaches 42 degree.

Residual heat blowing function

During heating, when the stopping condition for the compressor is reached, the compressor and the outdoor fan motor stop running while the louver moves to position L. The indoor fan will stop after running for 60s at setting speed.

12.5 8 Degree Heat Mode

Under heat mode, press “Save” button, the system will enter into 8 Degree Heat Mode.

1. 8 Degree Heat Mode can not exist together with Sleep mode. If Sleep Mode is selected, 8 degree Heat Mode will be canceled.
2. The SPT will be 8 degree and display will show the SPT,
3. Under this mode, IFAN can not be changed manually (Including Turbo speed)
4. Under this mode, IFAN will operate as following table when compressor is ON. When compressor stops, IFAN will operate as “Residual heat blowing function” (refer to 12.4.5)

Indoor Fan speed	High	Medium	Low
RAT	≤ 9	(9,11)	≥ 11

One speed should keep at least 210sec operating before switching to other speeds.

12.6 Auto Cool/Heat Mode

In AUTO mode, the system selects the running mode (COOL/HEAT/FAN) automatically according to the room temperature. The display shows the actual running mode and setting temperature.

There will be 30s delay for mode conversion.

1. When $RAT \geq 26$ degree, the cooling mode is selected.
2. When $RAT \leq 22$ degree, the unit runs in heating mode
3. When 22 degree $< RAT < 26$ degree, upon initial startup, the unit will enter auto mode and run in automatic fan mode. If the other mode changes into auto mode, the previous running mode will remain. (Except from Dry Mode, system will run in automatic fan mode)

12.7 Dry Mode

Dry Mode is same as Cool Mode in EEV, OFAN and compressor control except following:

- 1) IFAN will be forced to Low speed.
- 2) For indoor working under Dry mode, Max capacity output is 90% of Cool Mode

In this mode, the Reverse Valve will be OFF and the temperature setting range is 16~30.

12.8 Protections

There are 4 protection codes.

Normal (Norm) – unit operate normally.

Stop Rise (SR) – compressor frequency can not be raised but does not have to be decreased.

HzDown – Compressor frequency is reduced by 1Hz/s (2Hz/s for current protection)

Stop Compressor (SC) – Compressor is stopped.

12.8.1 Mode confliction

When there are different mode settings among active indoors:

a. First request priority:

The first IDU which requests different mode than STBY mode will set the new operation mode. Mode confliction will be decided comparing with other IDUs' modes. Cool (Dry) mode is conflict to Heat mode.

The mode will change once all the units exit the current operation mode.

b. Fan mode is conflict to Heat mode:

Heat Mode is the priority mode, Fan Mode is conflict to Heat Mode no matter the IDU is first IDU or not. The indoor will run in Heat Mode.

When the current IDU operating mode is conflict to other IDUs under operating, the current IDU:

1. IDU display will show "E7".
2. The operating mode is still transferred to the outdoor unit.

12.8.2 Indoor Coil Defrost Protection

During cooling operation, the signals being sent from the indoor unit allow the operating frequency limitation and then prevent freezing of the indoor heat exchanger.

Compressor will stop when $ICT \leq -1C$ for continuous 10sec.

If the unit stops as such protection for 6 times (the counter will be cleared after the compressor has run for 7min), it can not resume running automatically and display malfunction, it can resume by power reset.

12.8.3 Indoor/Outdoor Coil over Heating Protection

During heating operation, the signals being sent from the indoor unit/outdoor allow the operating frequency limitation and prevent abnormal high pressure.

Compressor frequency will be reduced when ICT/OCT reaches above 58C

Compressor will stop when ICT/OCT reaches 65C

If the unit stops as such protection for 6 times (the counter will be cleared after the compressor has run for 7min), it can not resume running automatically and display malfunction, it can resume by power reset.

12.8.4 Compressor over Heating Protection

The Discharging temperature is used as the compressor's internal temperature. If the discharge temperature rises above a certain level, the operating frequency upper limit is set to keep this temperature from going up further.

Compressor frequency will be reduced when CTT reaches above 97C
Compressor will stop when CTT reaches 110C

If the unit stops as such protection for 6 times (the counter will be cleared after the compressor has run for 7min), it can not resume running automatically and display malfunction, it can resume by power reset.

12.8.5 Compressor over Current Protection

Detect an input current by the CT during the compressor is running, and set the frequency upper limit from such input current. In case of heat pump model, this control is the upper limit control function of the frequency which takes priority of the lower limit of four way valve activating compensation.

Detail

For model 14: Compressor will stop when AC current $\geq 16.0A$ for continuously 2.5s
For model 18/30: Compressor will stop when AC current $\geq 20.0A$ for continuously 2.5s

If the unit stops as such protection for 6 times (the counter will be cleared after the compressor has run for 7min), it can not resume running automatically and display malfunction, it can resume by power reset.

12.8.6 Outdoor Coil Deicing Protection

This protection is for Heat Pump Only

This protection is carried out by the cooling cycle (reverse cycle). The defrosting time or outdoor heat exchanger temperature must be more than its setting values when finishing the deicing protection.

In the deicing protection, IFAN is forced OFF.

12.8.6.1 Deicing Starting Conditions

The starting conditions must be made with the outdoor air temperature (OAT) and outdoor coil temperature (OCT). Under the conditions that the system is in heating operation, after the time for defrosting is judged to be satisfied, if the temperature for deicing is satisfied after detections for continuous 1 minute, the deicing operation will start.

Deicing interval time is changed as a function of deicing time. If deicing time is shorter than former deicing time, the deicing interval time will be increased. If deicing time is longer than former deicing time, the deicing interval time will be decreased.

12.8.6.2 Deicing Protection Procedure

When starting deicing from Heat Mode, system will work as following:

- 1). Compressor stops. OFAN and RV will be OFF after 40s
- 3). Compressor starts and deicing time is counted. Compressor frequency will go to Deicing Frequency.

12.8.6.3 Exiting Deicing

System will exit the deicing until OCT reaches to certain value (depends on OAT) or the deicing time reaches 12 min as maximum.

12.8.7 Communication malfunction

Connected IDU number detection

If ODU does not receive correct signal from one IDU for 3min continuously, the ODU will take this IDU as not connected one. But ODU will still send the broadcast to this IDU. If response were received, then ODU will take it as connected.

12.8.8 IPM module protection

When the compressor starts, if there is over current or control voltage low for IPM module as some abnormal results, IPM will detect module protection signal as the unit is on. Once the module protective signal is detected, stop the unit with module protection immediately. If the module protection is resumed and compressor has stopped for 3min, the unit will be allowed to operate.

If the module protection continuously occurs for 6 times (the counter will be cleared after the compressor has run for 7min), it can not resume running automatically and display malfunction, it can resume by power reset.

12.8.9 HP switch protection

If the HP switch is opened for 3S continuously, the system will stop as protection

After the HP switch protection, if HP switch is resumed for continuous 6s, the system operating can be resumed by power reset.

12.8.10 Module overheating protection

If the module temperature is higher than 95C, the unit will stop. If module temperature is lower than 95C, and compressor has stopped for 3min, the unit will resume operating.

If the unit stops as module overheating protection for 6 times (the counter will be cleared after the

compressor has run for 7min), it can not resume running automatically and display malfunction, it can resume by power reset.

12.8.11 Compressor overload protection

If the compressor OLP is opened, the system will stop as protection

If the OLP is resumed and compressor has stopped for 3min, the unit will be allowed to operate.

If the unit stops as compressor overload protection occurred for 6 times continuously (the counter will be cleared after the compressor has run for 30min), it can not resume running automatically and display malfunction, it can resume by power reset.

12.8.12 Compressor Phase protection

If any phase is detected open when compressor starting, the system will stop as protection.

The protection will be cleared after 1 min and system will try to restart.

If the unit stops as Phase protection for 6 times (the counter will be cleared after the compressor has run for 7min), it can not resume running automatically and display malfunction, it can resume by power reset.

12.9 Operating the Unit from the ON/OFF Button

The ON/OFF button allows to operate the unit in AUTO mode, the microcomputer will monitor the room temperature and select the (COOL, HEAT, FAN) mode automatically, and temperature/Fan speed settings can not be changed.

12.10 Indoor Unit Controllers and Indicators

The following is schematic drawing for the display:

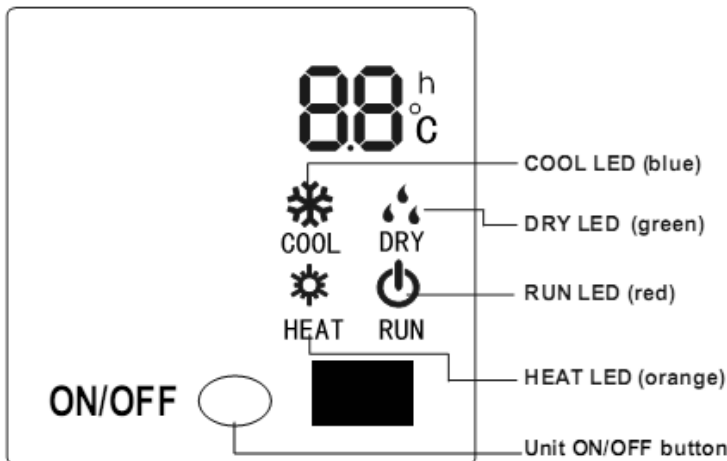

<p>RUN INDICATOR</p>	<p>1. Lights up when the Air Conditioner is connected to power and</p>
-----------------------------	--

	<p>the mode is STBY.</p> <p>2. When the unit is turned on remotely, the RUN LED goes out while the current setting running mode is displayed</p>
<p>COOL INDICATOR DRY INDICATOR HEAT INDICATOR</p>	<p>1. Lights up during specified operation mode (COOL/DRY/HEAT).</p>
<p>2* 7 segments display</p>	<p>1. In normal situation, the setting temperature is displayed.</p> <p>2. Shows outdoor temperature or indoor temperature when receiving the corresponding demand from controller. It resumes displaying setting temperature 5s later</p> <p>3. Shows H1 during deicing in heating mode.</p> <p>4. Shows the alarm code whenever there is an alarm.(Refer to Diagnostic part)</p>
<p>Unit ON/OFF Button</p>	<p>Single pressing: Unit will switch between Auto mode and STBY. System will select the COOL/HEAT/FAN mode automatically and temperature/Fan speed settings can not be changed.</p>

12.10.1 Installation Test

Installation test is to check any mistake in communication wiring or EEV wiring connections.

Start Installation Test:

RC setting: SPT=30, Cool Mode and press the button “-, +,-, +,-, +” continuously in 3 sec.

Unit operation during Installation test:

Unit will operate in cool mode (IFAN will stop), IDU will display “dd”. Total operating time depends on IDU numbers, for each IDU maximum operating time is 3min.

Finish the Installation test:

IDU will cancel displaying “dd”, and will display “dn” if any mistake of communication wiring or EEV wiring is detected from ODU.

12.11 Forced Deicing**Start Forced Deicing**

Under Heat Mode, RC setting with SPT=16, and press the button “+,-,+,-,+,-” continuously in 5 sec. The Forced Deicing request will be sent to ODU.

After ODU received the Forced Deicing request, IDU will cancel the setting and request of Forced Deicing

System operation will follow 12.8.6.2 and 12.8.6.3 during Forced Deicing.

12.12 Forced Mode (Compulsory operating function).**Entering into forced mode :**

After the unit is powered for 5mins, press the light button on remote controller for 3 times in 3s successively to enter into Freon recovery mode. “Fo” will be displayed. When Freon recovery mode operated for 25mins, all loads will operate in cooling mode. (The setting fan speed is high fan speed and the setting temperature is 16C)

Exiting forced mode:

Any signal from remote controller or button will exit the forced mode, and then the unit will operate at the current setting command.

Forced mode will also be exited after operating for 25mins and then the unit will operate with the last operating mode.

13. TROUBLESHOOTING

13.1 ELECTRICAL & CONTROL TROUBLESHOOTING

13.1.1 Precautions before Performing Inspection or Repair

Be cautious during installation and maintenance. Do operation following the regulations to avoid electric shock and casualty or even death due to drop from high altitude.

* **Static maintenance** is the maintenance during de-energization of the air conditioner. For static maintenance, make sure that the unit is de-energized and the plug is disconnected.

***Dynamic maintenance** is the maintenance during energization of the unit. Before dynamic maintenance, check the electricity and ensure that there is ground wire on the site. Check if there is electricity on the housing and connection copper pipe of the air conditioner with voltage tester. After ensure insulation place and the safety, the maintenance can be performed.

Take sufficient care to avoid directly touching any of the circuit parts without first turning off the power. At time such as when the circuit board is to be replaced, place the circuit board assembly in a vertical position. Normally, diagnose troubles according to the trouble diagnosis procedure as described below.(Refer to the check points in servicing written on the wiring diagrams attached to the indoor/outdoor units.)

Precautions when inspecting the control section of the outdoor unit:

A large-capacity electrolytic capacitor is used in the outdoor unit controller (inverter). Therefore, if the power supply is turned off, charge(charging voltage DC280V to 380V)remains and discharging takes a lot of time. After turning off the power source, if touching the charging section before discharging, an electrical shock may be caused.

The outdoor unit can not be started up until the unit is de-energized for 20min

13.1.2 Confirmation

13.1.2.1 Confirmation of Power Supply Confirm that the power breaker operates(ON) normally;

13.1.2.2 Confirmation of Power Voltage Confirm that power voltage is AC220~240V +/- 10%. If power voltage is not in this range, the unit may not operate normally.

13.1.3 Fault Code display from ODU

The ODU will show the active fault code by its LED1, LED2, LED3 and LED4.

When more than one active fault codes exist, each fault code will display in 5s interval.

□ – LED OFF, ■ – LED ON, ☆ – LED Blinking

No.	Fault code	LED1	LED2	LED3	LED4
0	STBY	□	□	□	□
1	Operation (COMP ON)	■	□	□	□
2	Stop for compressor OLP protection	☆	□	□	□
3	Stop for compressor over heating protection	□	■	□	□
4	Stop for ODU over heating protection	■	■	□	□
5	Stop for HP switch protection	☆	■	□	□
6	Stop for AC over current protection	□	☆	□	□
7	IPM protection	■	☆	□	□
8	IPM overheating protection	☆	☆	□	□
9	PFC protection	□	□	■	□
10	Stop for DC over current protection	■	□	■	□
11	DC over Voltage protection	☆	□	■	□
12	DC under Voltage protection	□	■	■	□
13	Compressor startup failure	■	■	■	□
14	Desynchronizing of compressor	☆	■	■	□
15	Lack phase protection of compressor	□	☆	■	□
16	Compressor phase current detection problem	■	☆	■	□
17	EEPROM failure	☆	☆	■	□
18	DC power circuit short	□	□	☆	□
19	Deicing	■	□	☆	□
20	Oil return	☆	□	☆	□
21	Compressor Stop Rise	□	■	☆	□
22	Compressor Hz Down	■	■	☆	□
23	Stop Rise/Hz down from IDU-A	☆	■	☆	□
24	Stop Rise/Hz down from IDU-B	□	☆	☆	□
25	Stop Rise/Hz down from IDU-C	■	☆	☆	□
26	Stop Rise/Hz down from IDU-D	☆	☆	☆	□
27	OAT failure	□	□	□	■
28	OCT failure	■	□	□	■
29	CTT failure	☆	□	□	■
30	HST failure	□	■	□	■
31	RLT-A failure	■	■	□	■
32	RGT-A failure	☆	■	□	■
33	RLT-B failure	□	☆	□	■
34	RGT-B failure	■	☆	□	■
35	RLT-C failure	☆	☆	□	■

TROUBLESHOOTING

36	RGT-C failure	□	□	■	■
37	RLT-D failure	■	□	■	■
38	RGT-D failure	☆	□	■	■
39	IDU-A mode conflict	□	■	■	■
40	IDU-B mode conflict	■	■	■	■
41	IDU-C mode conflict	☆	■	■	■
42	IDU-D mode conflict	□	☆	■	■
43	Chanel-A communication malfunction	■	☆	■	■
44	Chanel-B communication malfunction	☆	☆	■	■
45	Chanel-C communication malfunction	□	□	☆	■
46	Chanel-D communication malfunction	■	□	☆	■
47	IDU-A defrost protection	☆	□	☆	■
48	IDU-B defrost protection	□	■	☆	■
49	IDU-C defrost protection	■	■	☆	■
50	IDU-D defrost protection	☆	■	☆	■
51	IDU-A overheating protection	□	☆	☆	■
52	IDU-B overheating protection	■	☆	☆	■
53	IDU-C overheating protection	☆	☆	☆	■
54	IDU-D overheating protection	□	□	□	☆

13.1.4 Fault Code display from IDU

If the malfunction still exists 4min later after stop of unit due to compressor protection, error code will be directly displayed though indoor display. In other situations, fault code can be displayed by pressing LIGHT button 6 times within 4s.

Fault code can be displayed on 2*7 segments or by the LEDs blinking (OFF for 3s and then with certain blinking as following)

Fault description	2*7 segments	LEDs blinking			Possible Reason
		RUN	COOL	HEAT	
HP switch protection	E1	1			1. Refrigerant was superabundant 2. Poor heat exchange (including blockage and bad radiating environment) 3. Too high ambient temperature
Indoor coil defrost Protection	E2	2			1. Poor air-return in indoor unit 2. Fan speed is abnormal 3. Evaporator is dirty.
Compressor over Heating Protection	E4	4			1. EEV connection problem or damage 2. Refrigerant leakage 3. Poor heat exchange
AC Over current protection	E5	5			1. Supply voltage is unstable 2. Supply voltage is too low and load is too high
Communication malfunction	E6	6			1. Wiring mistakes 2. IDU or ODU PCB problem
Mode conflict	E7	7			Mode conflict to other IDU
Indoor coil/Outdoor coil over heating protection	E8	8			1. Too high ambient temperature 2. Poor heat exchange (including blockage and bad radiating environment)
No feedback of indoor motor	H6	11			1. IFAN motor damaged 2. IFAN motor blocked 3. IDU PCB problem
Malfunction protection of jumper cap	C5	15			Poor connection of the jumper on indoor PCB.
Zero-crossing protection (IDU)	U8	17			1. IFAN motor damaged 2. Zero-crossing circuit damaged on IDU PCB
Mismatch of IDU and ODU	LP	19			
RAT failure	F1		1		1. Senor was broken or damaged 2. PCB temperature detection circuit has problem
ICT failure	F2		2		
OAT failure	F3		3		
CTT failure	F5		5		
DC over voltage	PH		11		1. AC input voltage is too high. 2. Reactor has problem 3. ODU PCB has problem
OCT failure	F4		18		1. Senor was broken or damaged 2. PCB temperature detection circuit has problem
RLT failure	b5		19		
RGT failure	b7		22		
Compressor overload protection	H3			3	1. EEV connection problem or damaged 2. Refrigerant leakage 3. OLP damaged
IPM protection	H5			5	1. Abnormal power input voltage. 2. Compressor wiring mistake. 3. Liquid and gas valve are not open. 4. EEV damaged or not proper working 5. Poor heat exchange. 6. Over charged system.

PFC protection	HC			6	<ol style="list-style-type: none"> 1. PFC module assembly problem. 2. Poor heat exchange of Heatsink 3. PFC reactor problem. 4. Abnormal power voltage 5. PFC circuit problem on PCB
Desynchronizing of compressor	H7			7	<ol style="list-style-type: none"> 1. Abnormal power input voltage. 2. Compressor wiring mistake. 3. Liquid and gas valve are not open. 4. EEV damaged or not proper working 5. Poor heat exchange. 6. Over charged system.
Compressor start-up failure	Lc			11	<ol style="list-style-type: none"> 1. Compressor wiring mistake 2. Over charged system 3. System not balanced before compressor starting 4. Compressor problem
Compressor phase current detection problem	U1			12	Phase current detection circuit for compressor has problem.
DC over current	P5			15	<ol style="list-style-type: none"> 1. Abnormal power input voltage. 2. Compressor wiring mistake. 3. Liquid and gas valve are not open. 4. EEV damaged or not proper working 5. Poor heat exchange. 6. Over charged system.
Charging malfunction of capacitor	PU			17	<ol style="list-style-type: none"> 1. Reactor open 2. Charging relay or other components damaged on PCB.
HST failure	P7			18	<ol style="list-style-type: none"> 1. Sensor was broken or damaged 2. PCB temperature detection circuit has problem
HST over heating protection	P8			19	<ol style="list-style-type: none"> 1. Insufficient attachment of IPM module to Heatsink 2. Outdoor PCB problem.
DC under voltage	PL			21	<ol style="list-style-type: none"> 1. AC input voltage is too low 2. Reactor has problem 3. ODU PCB has problem
Lack Phase Protection of Compressor	Ld				<ol style="list-style-type: none"> 1. Compressor wiring problem 2. Compressor problem 3. IPM module problem or compressor current detection circuit has problem 4. Compressor malfunction due to EEV problem

13.1.5 Checking the refrigeration system

Checking system pressures and other thermodynamic measures should be done when system is in Test Mode (in Test mode, system operates in fixed settings). The performance curves given in this manual are given for unit performance in test mode when high indoor fan speed is selected.

Entering test mode please refer to section 12- Control system.

13.2 Simple procedures for checking the Main Parts

13.2.1 Checking Mains Voltage.

Confirm that the Mains voltage is between 198 and 264 VAC. If Mains voltage is out of this range, abnormal operation of the system is expected. If in range check the Power (Circuit) Breaker and look for broken or loosed cable lugs or wiring mistake(s).

13.2.2 Checking Power Input.

If Indoor unit power LED is unlighted, power down the system and check the fuse of the Indoor unit. If the fuse is OK replace the Indoor unit controller. If the fuse has blown, replace the fuse and power up again.

Checking Power Input procedure for the Outdoor unit is the same as with the Indoor unit.

13.2.3 Checking the Outdoor Fan Motor.

Enter Test Mode (where the OFAN speed is high)

Check the voltage between two pins(Hi and N) of connector Controller OFAN, normal voltage is 220VAC.

13.2.4 Checking the Compressor.

The compressor is brushless permanence magnetic DC motor. Three coil resistance is same. Check the resistance between three poles. The normal value should is ~0.452ohm.(Model 14) and ~0.88ohm(Model 18/30)Pay attention U,V, W are respective to connect to RED,YELLOW,BLUE wires.

13.2.5 Checking the Reverse Valve (RV).

Running in heating mode, check the voltage between two pins of reverse valve connector, normal voltage is 220VAC.

14. CHARACTERISTICS OF SENSOR

14.1.1 RAT/OAT

RAT/OAT R-T chart

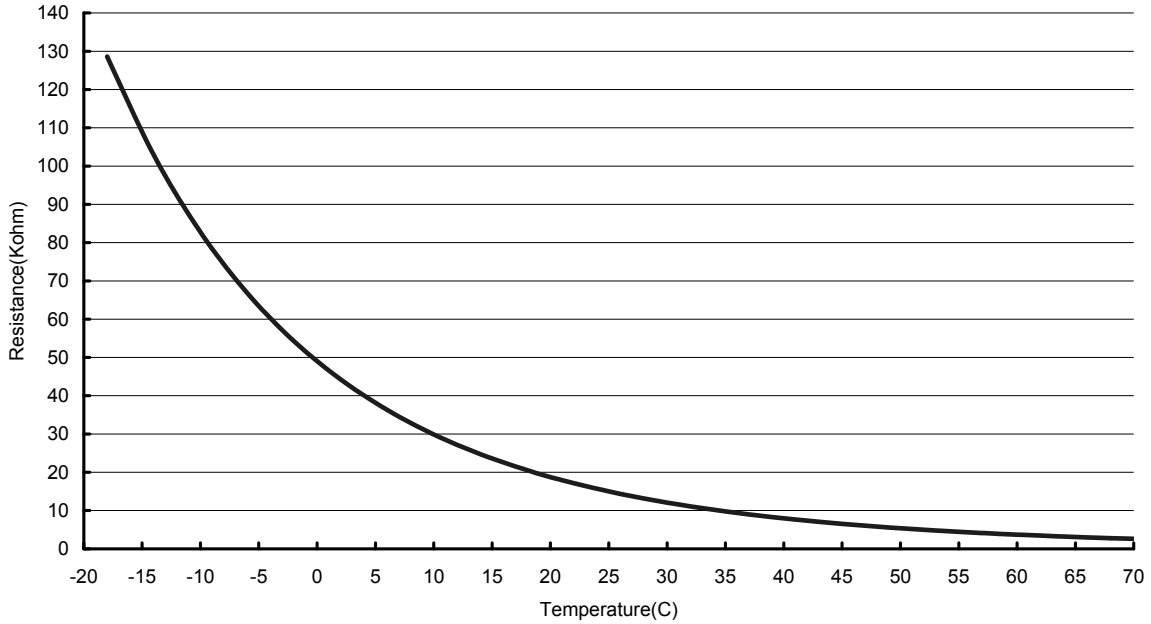

14.1.2 ICT/OCT/RGT/RLT

ICT/OCT R-T Chart

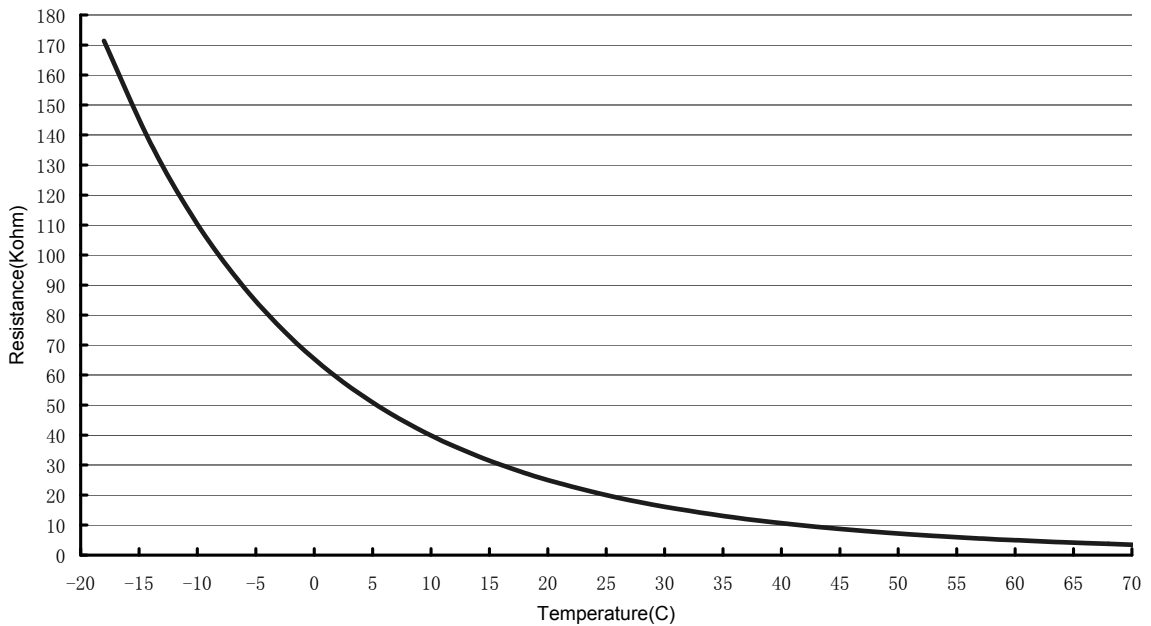

Downloaded from www.Manualslib.com manuals search engine

14.1.3 CTT

CTT R-T Chart

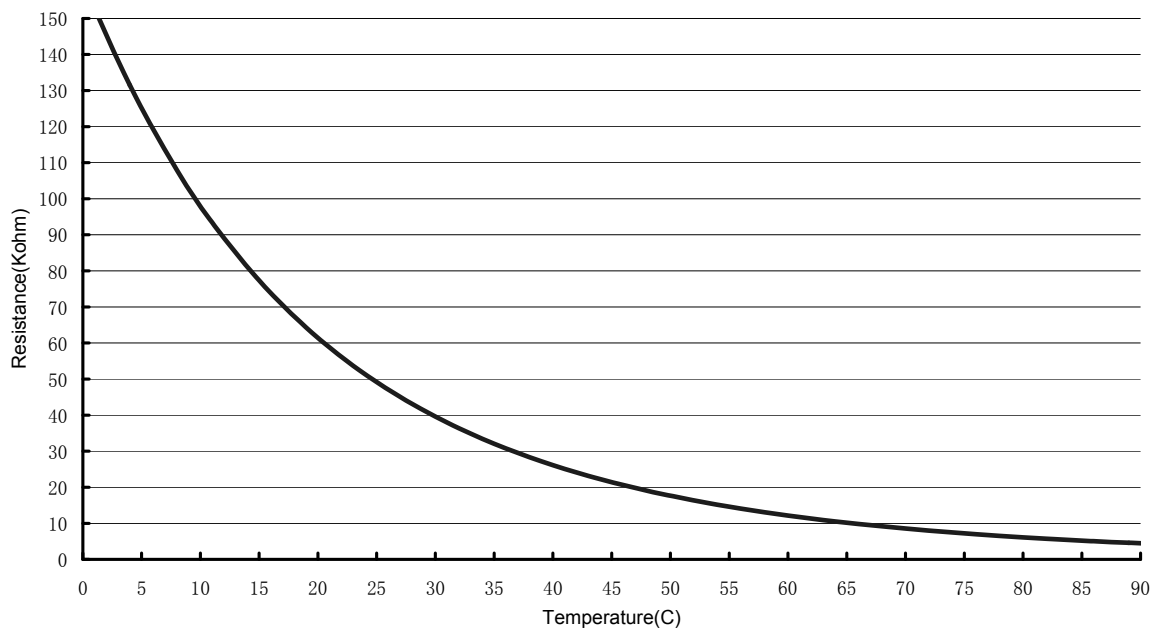

15. EXPLODED VIEW & SPARE PART LIST

15.1 Exploded view of indoor unit: HYD009-012, HZD009-012

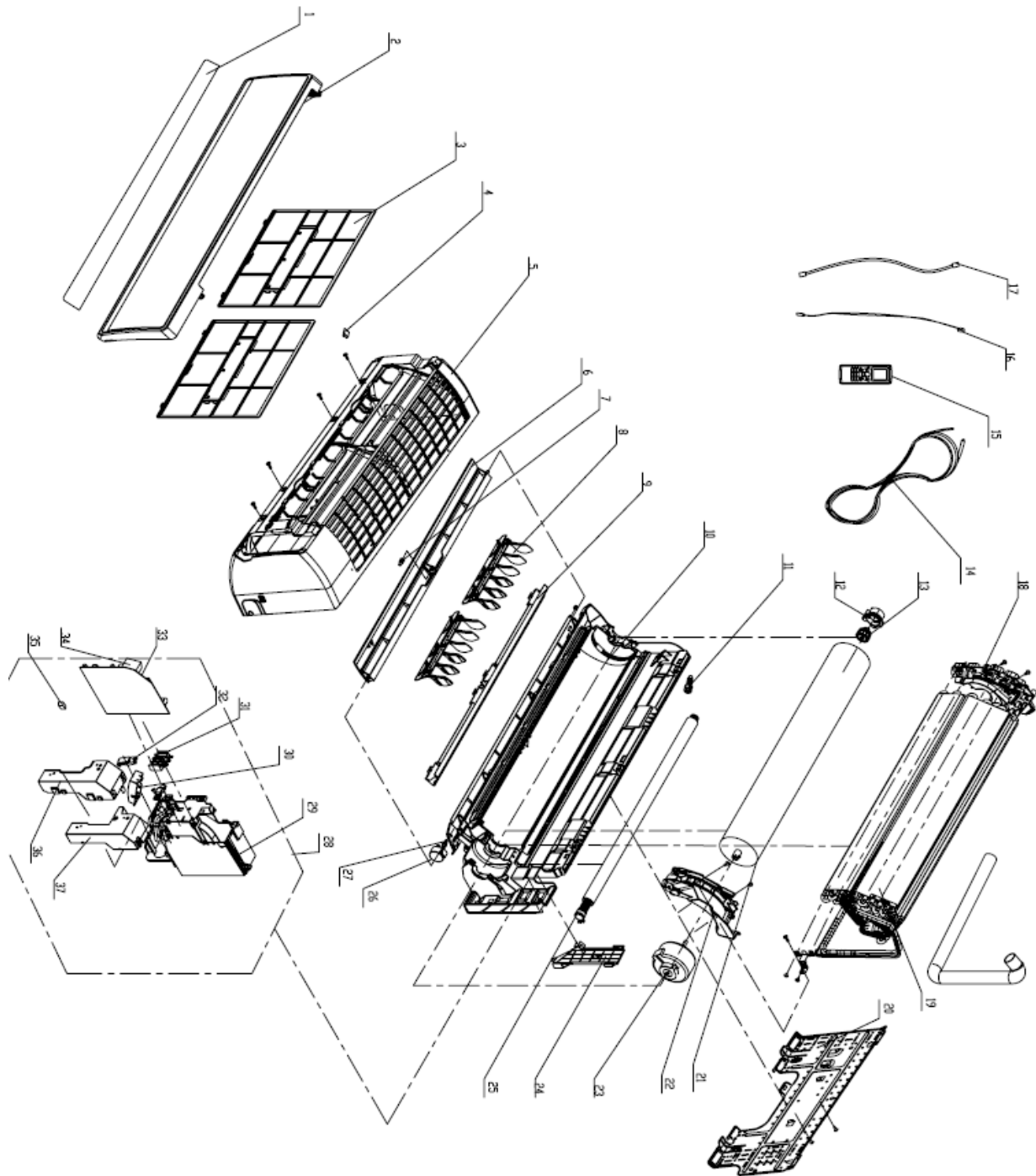

15.2 Spare part list of indoor Unit: HYD009

NO.	Part Code	Part Description	qty
1	02122033	Decorative Strip	1
2	2001237604_K46462	Front Panel Assy	1
3	1112208201	Filter Sub-Assy	2
4	24252019	Screw Cap	1
5	2001237501_K46462	Front Case Assy	1
6	10512119	Guide Louver	1
7	1054202001	Shaft of guide louver	2
8	10512160	Air Louver	2
9	26112486	Helicoid tongue	1
10	2220211901_K46462	Rear Case assy	1
11	76712020	Pipe plug (outlet)	1
12	10542024	Axial Bush sub-assy	1
13	76512011	Damping washer sub-assy	1
14	400204056	Connecting Cable	1
15	30510136_K46462	Remote Controller	1
16	39000305	sensor	1
17	390000453	Ambient Temperature Sensor	1
18	24212108	Evaporator Support	1
19	01002270	Evaporator Assy	1
20	0125201801A	Wall Mounting Frame	1
21	10352423	Cross Flow Fan	1
22	26112191	Motor Press Plate	1
23	15002002	Motor Sub-Assy	1
24	26112218	Baffle Plate	1
25	0523204101	Drainage Pipe Sub-assy	1
26	1521210701	Step Motor	1
27	73012005	Crank	1
28	2020225308	Electric Box Assy	1
29	20112086	Electric Box	1
30	22242084	Indicator Light Cover	1
31	42011233	4-bit Terminal Board	1
32	22242083	Indicator shield cover	1
33	30138682	Main Board	1
34	33010002	Capacitor CBB61	1
35	4202300101	Jumping Connector	1
36	20122109	Electric Box Cover Sub-Assy	1
37	20122106	Electric Box Cover	1

15.3 Spare part list of indoor Unit: HYD012

NO.	Part Code	Part Description	qty
1	02122033	Decorative Strip	1
2	2001237604_K46462	Front Panel Assy	1
3	1112208201	Filter Sub-Assy	2
4	24252019	Screw Cap	1
5	2001237501_K46462	Front Case Assy	1
6	10512119	Guide Louver	1
7	1054202001	Shaft of guide louver	2
8	10512160	Air Louver	2
9	26112486	Helicoid tongue	1
10	2220211901_K46462	Rear Case assy	1
11	76712020	Pipe plug (outlet)	1
12	10542024	Axial Bush sub-assy	1
13	76512011	Damping washer sub-assy	1
14	400204056	Connecting Cable	1
15	30510136_K46462	Remote Controller	1
16	39000305	sensor	1
17	390000453	Ambient Temperature Sensor	1
18	24212108	Evaporator Support	1
19	01002745	Evaporator Assy	1
20	0125201801A	Wall Mounting Frame	1
21	10352423	Cross Flow Fan	1
22	26112191	Motor Press Plate	1
23	15002002	Motor Sub-Assy	1
24	26112218	Baffle Plate	1
25	0523204101	Drainage Pipe Sub-assy	1
26	1521210701	Step Motor	1
27	73012005	Crank	1
28	2020225309	Electric Box Assy	1
29	20112086	Electric Box	1
30	22242084	Indicator Light Cover	1
31	42011233	4-bit Terminal Board	1
32	22242083	Indicator shield cover	1
33	30138682	Main Board	1
34	33010002	Capacitor CBB61	1
35	4202300103	Jumping Connector	1
36	20122109	Electric Box Cover Sub-Assy	1
37	20122106	Electric Box Cover	1

15.4 Spare part list of indoor Unit: HZD009

NO.	Part Code	Part Description	qty
1	20192439	Decorative Strip	1
2	20012823	Front Panel Assy	1
3	1112208201	Filter Sub-Assy	2
4	24252019	Screw Cap	1
5	20012824	Front Case Assy	1
6	10512119	Guide Louver	1
7	1054202001	Shaft of guide louver	2
8	10512160	Air Louver	2
9	26112486	Helicoid tongue	1
10	2220211901_K46462	Rear Case assy	1
11	76712020	Pipe plug (outlet)	1
12	10542024	Axial Bush sub-assy	1
13	76512011	Damping washer sub-assy	1
14	400204056	Connecting Cable	1
15	30510136_K46462	Remote Controller	1
16	39000305	sensor	1
17	390000453	Ambient Temperature Sensor	1
18	24212108	Evaporator Support	1
19	01002270	Evaporator Assy	1
20	0125201801A	Wall Mounting Frame	1
21	10352423	Cross Flow Fan	1
22	26112191	Motor Press Plate	1
23	15002002	Motor Sub-Assy	1
24	26112218	Baffle Plate	1
25	0523204101	Drainage Pipe Sub-assy	1
26	1521210701	Step Motor	1
27	73012005	Crank	1
28	2020225308	Electric Box Assy	1
29	20112086	Electric Box	1
30	22242084	Indicator Light Cover	1
31	42011233	4-bit Terminal Board	1
32	22242083	Indicator shield cover	1
33	30138682	Main Board	1
34	33010002	Capacitor CBB61	1
35	4202300101	Jumping Connector	1
36	20122109	Electric Box Cover Sub-Assy	1
37	20122106	Electric Box Cover	1
	24212910	Support of catechin	2
	11012025	Air Cleaner	1
	111220071	Photo catalysis Filter	1

15.5 Spare part list of indoor Unit: HZD012

NO.	Part Code	Part Description	qty
1	20192439	Decorative Strip	1
2	20012823	Front Panel Assy	1
3	1112208201	Filter Sub-Assy	2
4	24252019	Screw Cap	1
5	20012824	Front Case Assy	1
6	10512119	Guide Louver	1
7	1054202001	Shaft of guide louver	2
8	10512160	Air Louver	2
9	26112486	Helicoid tongue	1
10	2220211901_K46462	Rear Case assy	1
11	76712020	Pipe plug (outlet)	1
12	10542024	Axial Bush sub-assy	1
13	76512011	Damping washer sub-assy	1
14	400204056	Connecting Cable	1
15	30510136_K46462	Remote Controller	1
16	39000305	sensor	1
17	390000453	Ambient Temperature Sensor	1
18	24212108	Evaporator Support	1
19	01002745	Evaporator Assy	1
20	0125201801A	Wall Mounting Frame	1
21	10352423	Cross Flow Fan	1
22	26112191	Motor Press Plate	1
23	15002002	Motor Sub-Assy	1
24	26112218	Baffle Plate	1
25	0523204101	Drainage Pipe Sub-assy	1
26	1521210701	Step Motor	1
27	73012005	Crank	1
28	2020225309	Electric Box Assy	1
29	20112086	Electric Box	1
30	22242084	Indicator Light Cover	1
31	42011233	4-bit Terminal Board	1
32	22242083	Indicator shield cover	1
33	30138682	Main Board	1
34	33010002	Capacitor CBB61	1
35	4202300103	Jumping Connector	1
36	20122109	Electric Box Cover Sub-Assy	1
37	20122106	Electric Box Cover	1
	11012025	Air Cleaner	1
	111220071	Photo catalysis Filter	1
	24212910	Support of catechin	2

15.6 Exploded view of indoor unit: HYD018, HZD018

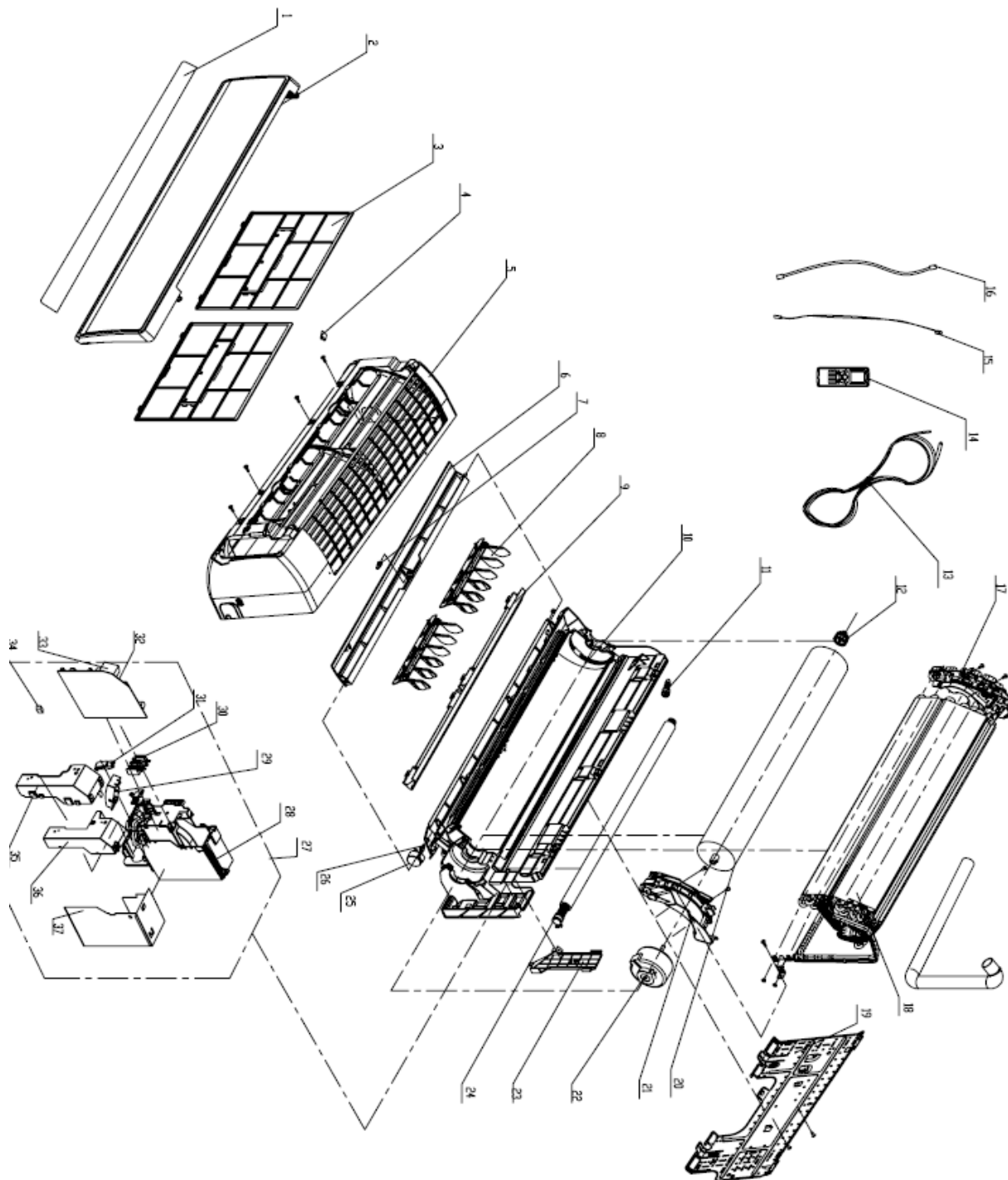

15.7 Spare part list of indoor Unit: HYD018

NO.	Part Code	Part Description	qty
2	20012663	Front Case	1
	20012496_K46462	Front Panel Assy	1
3	11122104	Filter Sub-Assy	2
4	242520041	Screw Cover	1
5	20012497_K46462	Front Case Assy	1
6	10512140	Guide Louver	1
7	10542008	Axial Bush (guide louver)	1
8	10512160	Air Louver	2
9	26112232	Helicoid tongue	1
10	22202154	Rear Case assy	1
11	76712012	Water Tray Glue Plug	1
12	76512051	O-Gasket sub-assy of Bearing	1
13	400204056	Connecting Cable	0
14	30510136_K46462	Remote Controller	1
15	390000591	Tube Sensor (20K black)	1
16	390000453	Ambient Temperature Sensor	1
17	24212119	Evaporator Support	1
18	0100260301	Evaporator Assy	1
19	01252484	Wall Mounting Frame	1
20	10352036	Cross Flow Fan	1
21	26112231	Motor Press Plate	1
22	15012116	Motor	1
23	26112164	Pipe Clamp	1
24	0523001407	Drainage hose	1
25	15012086	Step Motor	1
26	10582070	Crank	1
27	2020240402	Electric Box Assy	1
28	20112103	Electric Box	1
29	22242084	Indicator Light Cover	1
30	4201026601	Terminal Board(three-bit)	1
31	22242083	Indicator shield cover	1
32	30138685	Main Board	1
33	33010043	Capacitor	1
34	4202300105	Jumper Cap	1
35	01592088	Shield Cover of Electric box Cover	1
36	20122123	Electric Box Cover	1
37	01592087	Shield cover of Electric Box	1
	10512037	Left Axial Bush	1
	30568112	Display Board	1
	11012025	Air Cleaner	1
	111220071	Photo catalysis Filter	1

15.8 Spare part list of indoor Unit: HZD018

NO.	Part Code	Part Description	qty
1	none	Decorative Strip	0
2	20012872_K46462	Front Panel Assy	1
3	11122104	Filter Sub-Assy	2
4	242520041	Screw Cover	1
5	20012873	Front Case Assy	1
6	10512140	Guide Louver	1
7	10542008	Axial Bush (guide louver)	1
8	10512160	Air Louver	2
9	26112232	Helicoid tongue	1
10	22202154	Rear Case assy	1
11	76712012	Water Tray Glue Plug	1
12	76512051	O-Gasket sub-assy of Bearing	1
13	400204056	Connecting Cable	1
14	30510136_K46462	Remote Controller	1
15	390000591	Tube Sensor (20K black)	1
16	390000453	Ambient Temperature Sensor	1
17	24212119	Evaporator Support	1
18	01002603	Evaporator Assy	1
19	01252484	Wall Mounting Frame	1
20	10352036	Cross Flow Fan	1
21	26112231	Motor Press Plate	1
22	15012116	Motor	1
23	26112164	Pipe Clamp	1
24	0523001407	Drainage hose	1
25	15012086	Step Motor	1
26	10582070	Crank	1
27	2020240402	Electric Box Assy	1
28	20112103	Electric Box	1
29	22242084	Indicator Light Cover	1
30	4201026601	Terminal Board(three-bit)	1
31	22242083	Indicator shield cover	1
32	30138685	Main Board	1
33	33010043	Capacitor	1
34	4202300105	Jumper Cap	1
35	01592088	Shield Cover of Electric box Cover	1
36	20122123	Electric Box Cover	1
37	01592087	Shield cover of Electric Box	1
	11012025	Air Cleaner	1
	400300848	Signal Wire	1
	10512037	Left Axial Bush	1
	06643008	Tube Connector Assy	1
	30568112	Display Board	1
	111220071	Photo catalysis Filter	1

15.9 Exploded view of outdoor unit: YBZ214

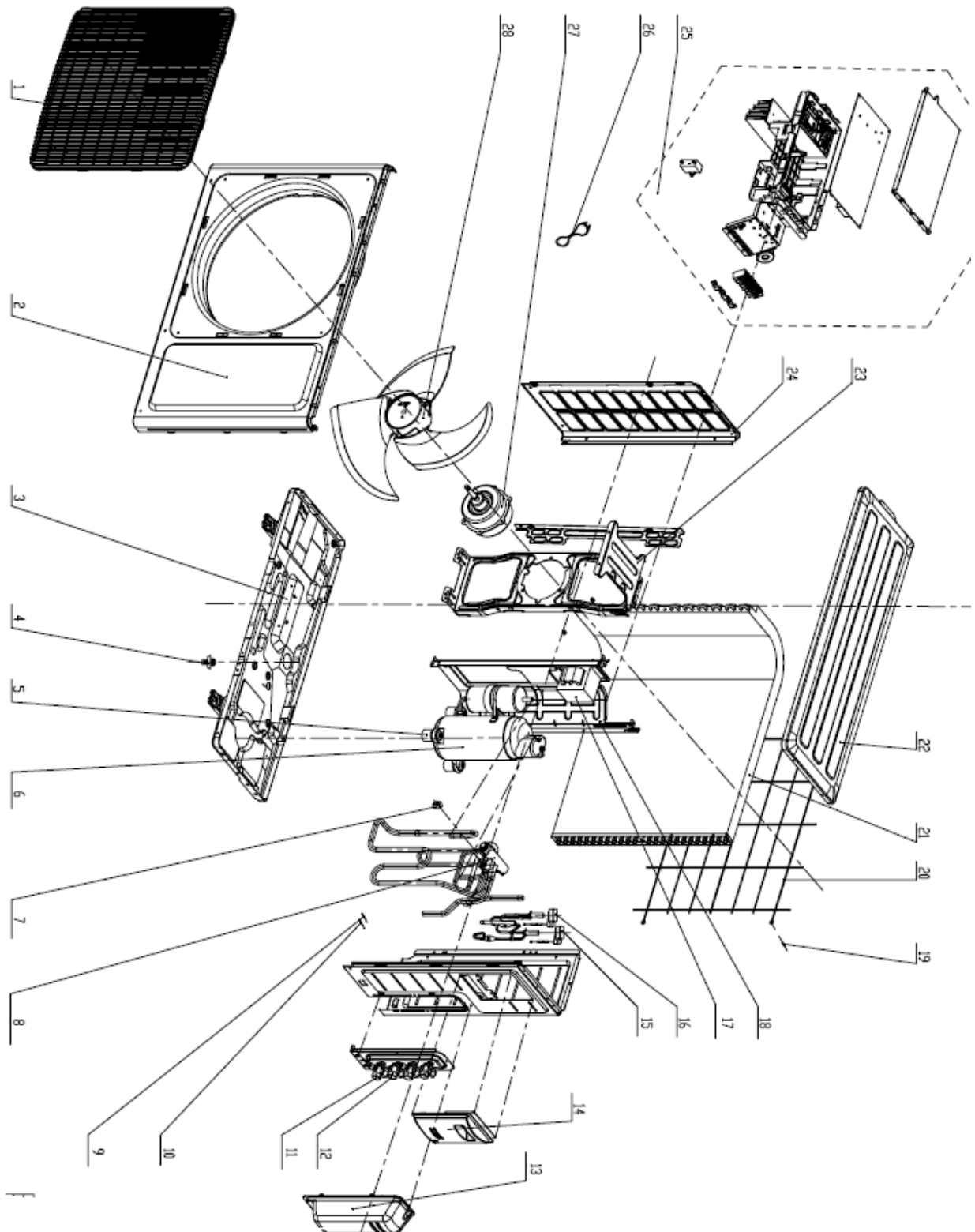

15.10 Spare part list of outdoor Unit: YBZ214

NO.	Part Code	Part Description	qty
1	22413015	Front Grill	1
2	01433034P	Cabinet	1
3	01205161P	Chassis Sub-assy	1
4	26113009	Drainage Joint	1
5	76710236	Compressor Gasket	3
6	00103501	Compressor And Fittings C-6RZ146H1A	1
7	4300040033	4-way Valve Fittings	1
8	03123438	4-way Valve Assy	1
9	3900007301	Temperature Sensor	1
10	39000073	Tube Temperature Sensor	1
11	071302391	Cut-off Valve	2
12	07130239	Cut-off Valve	2
13	22242101	Valve cover	1
14	26233048	Big Handle	1
15	4300008401	Electric expand valve fitting	1
16	43000084	Electric expand valve fitting	1
17	43120130	PFC Inductance	1
18	01233117	Clapboard Sub-Assy	1
19	3900030901	Temperature Sensor	1
20	01475019	Rear Grill	1
21	01113763	Condenser Assy	1
22	01253034P	Top Cover	1
23	01703398	Motor Support Sub-Assy	1
24	01303169P	Left Side Plate	1
25	02603411	Electric Box Assy	1
26	40020318	Connecting Cable	1
27	15013162	Fan Motor	1
28	10333010	Axial Flow Fan	1
	30033075	Filter Board	1
	430004032	4-way Valve	1
	07245101	Silencer	1
	420111041	Terminal Board	2
	42010178	Terminal Board	1
	0721004501	Strainer	1
	42020063	Sensor Insert	4
	33010011	Capacitor	1
	20113013	Electric Box	1
	30138633	Main Board	1
	07103067	Valve support assy	1
	32003001	OH Thermistor(compressor)	1

15.11 Exploded view of outdoor unit: YBZ318

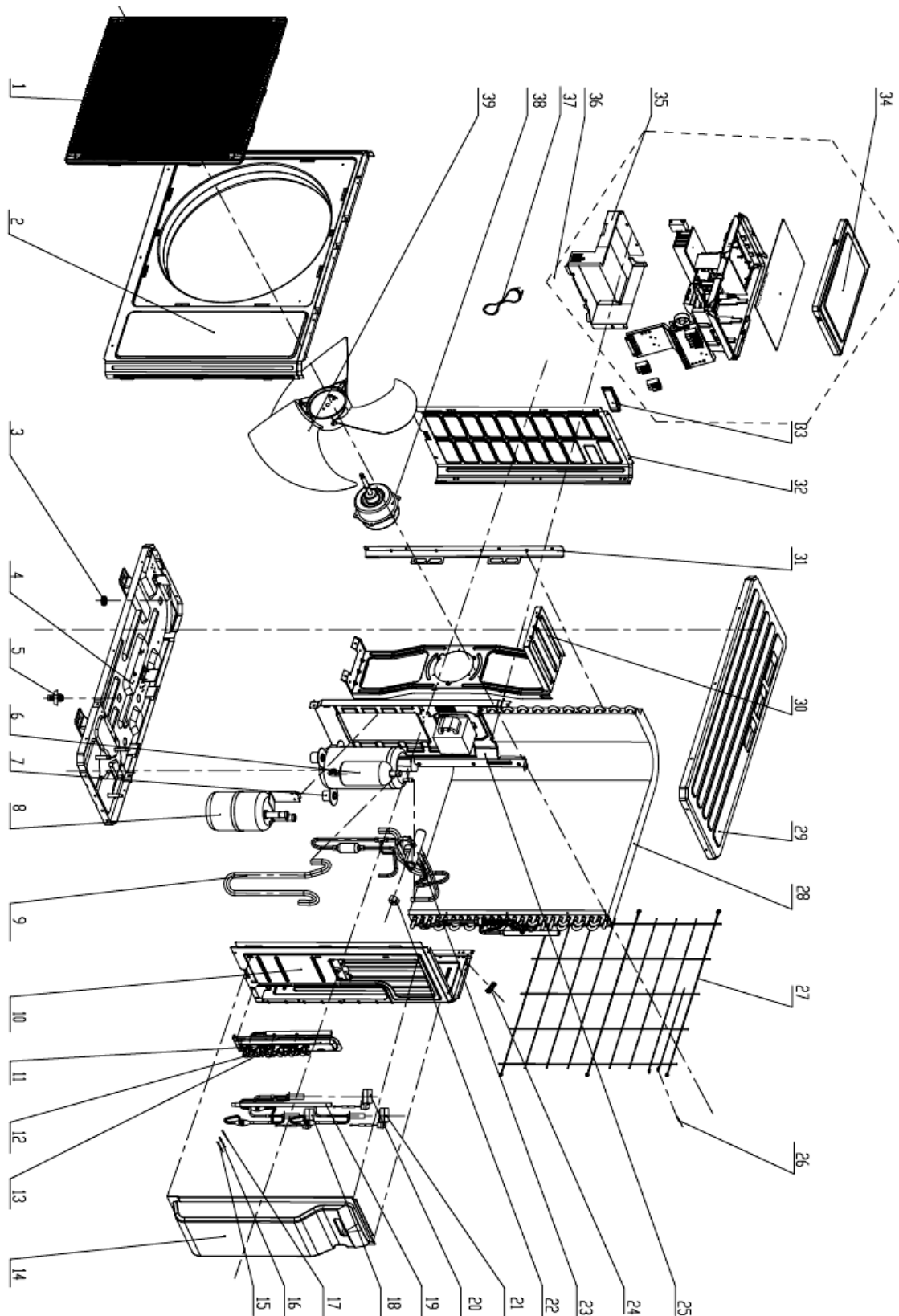

15.12 Spare part list of outdoor Unit: YBZ318

NO.	Part Code	Part Description	qty
1	22415002	Front grill	1
2	01535008P	Front Panel	1
3	06813401	Choke Plug	3
4	01203942P	Chassis Sub-assy	1
5	06123401	Drainage Connector	1
6	00105036	Compressor and fittings	1
7	76710207	Rubber Grommet	3
8	07225017	Gas-liquid Separator Assy	1
9	03723455	Inhalation Tube	1
10	01303194P	Right Side Plate	1
11	0710306601	Valve support assy	1
12	071302391	Cut-off Valve	3
13	07130239	Cut-off Valve	3
14	20123029	Valve cover	1
15	3900007302	Temperature Sensor	1
16	3900007301	Temperature Sensor	1
17	39000073	Tube Temperature Sensor	1
18	4300008402	Electric expand valve fitting	1
19	07133456	Electronic Expansion Valve assy	1
20	4300008401	Electric expand valve fitting	1
21	43000084	Electric expand valve fitting	1
22	4300040033	4-way Valve Fittings	1
23	03123415	4-way Valve Assy	1
24	26115004	Wiring clamp	1
25	01233116	Clapboard assy	1
26	3900030901	Temperature Sensor	1
27	01473043	Rear Grill	1
28	01113710	Condenser Assy	1
29	01255005P	Top Cover	1
30	0170512001	Motor Support Sub-Assy	1
31	01173415	Condenser support plate	1
32	01305041P	Left Side Plate	1
33	26235401	Small Handle	1
34	01413150	Electric Box Cover	1
35	01413148	Electric box (fireproofing)	1
36	0260337201	Electric Box Assy	1
37	400205405	Connecting Cable	1
38	1501506303	Fan Motor	1
39	10335008	Axial Flow Fan	1
	76518732	Electric Heater	1
	33010010	Capacitor CBB61 3.5kuF/450V	1
	430004032	4-way Valve	1
	30138710	Main Board	1
	460200061	Pressure Switch	1

15.13 Exploded view of outdoor unit: YBZ430

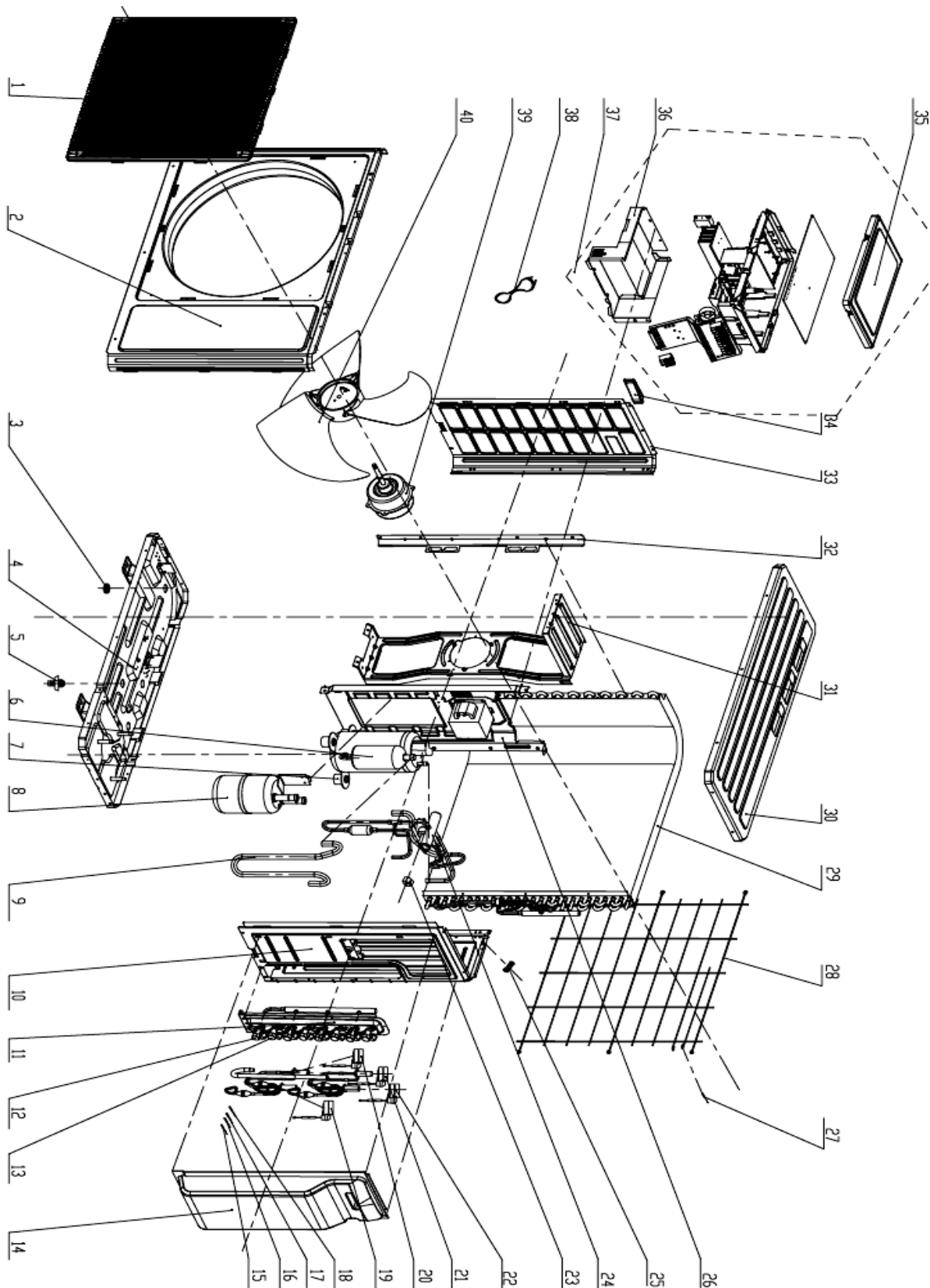

15.14 Spare part list of outdoor Unit: YBZ430

NO.	Part Code	Part Description	qty
1	22415002	Front grill	1
2	01535008P	Front Panel	1
3	06813401	Choke Plug	3
4	01203942P	Chassis Sub-assy	1
5	06123401	Drainage Connector	1
6	00105036	Compressor and fittings	1
7	76710207	Rubber Grommet	3
8	07225017	Gas-liquid Separator Assy	1
9	03723455	Inhalation Tube	1
10	01303194P	Right Side Plate	1
11	07103066	Valve support assy	1
12	071302391	Cut-off Valve	4
13	07130239	Cut-off Valve	4
14	20123029	Valve cover	1
15	3900007303	Temperature Sensor	1
16	3900007302	Temperature Sensor	1
17	3900007301	Temperature Sensor	1
18	39000073	Tube Temperature Sensor	1
19	4300008403	Electric expand valve fitting	1
20	4300008402	Electric expand valve fitting	1
21	4300008401	Electric expand valve fitting	1
22	43000084	Electric expand valve fitting	1
23	4300040033	4-way Valve Fittings	1
24	03123415	4-way Valve Assy	1
25	26115004	Wiring clamp	1
26	01233116	Clapboard assy	1
27	3900030901	Temperature Sensor	1
28	01473043	Rear Grill	1
29	01113710	Condenser Assy	1
30	01255005P	Top Cover	1
31	0170512001	Motor Support Sub-Assy	1
32	01173415	Condenser support plate	1
33	01305041P	Left Side Plate	1
34	26235401	Small Handle	1
35	01413150	Electric Box Cover	1
36	01413148	Electric box (fireproofing)	1
37	02603372	Electric Box Assy	1
38	400205405	Connecting Cable	1
39	1501506303	Fan Motor	1
40	10335008	Axial Flow Fan	1
	30138571	Main Board	1
	460200061	Pressure Switch	1
	430004032	4-way Valve	1
	33010010	Capacitor CBB61 3.5kuF/450V	1
	76518732	Electric Heater	1

APPENDIX