

BRIVIS INVERTER HI-WALL SPLIT SYSTEM



USER MANUAL

HSNBR25 - HSNBR32

HSNBR42 - HSNBR50

HSNBR70 - HSNBR80

Thank you for purchasing your Brivis Air Conditioning system.
Please read this user manual carefully prior to operation

Due to our policy of continuous improvement, product specification
and details are subject to change without prior notice.

Please contact Brivis on 1300 BRIVIS - 1300 274847 for further information.

READ THIS MANUAL FIRST

Please keep this manual in a safe place where you can easily find it. Inside you will find many helpful hints on how to use and properly maintain your Brivis system. Just a little preventative care on your part can save you a great deal of time and money over the life of your Brivis system. You'll find many answers to common problems in the chart of troubleshooting tips. If you review the troubleshooting tips first, you may not need to call for service.

CONTENTS

ENVIRONMENTAL RESPONSIBILITY

Environment.....2

SAFETY PRECAUTIONS

Warning3
 Caution4

OPERATING INSTRUCTIONS

Component names5
 Special functions6
 Operating temperature limits7
 Manual operation7
 Airflow direction control8
 How the air conditioner works9

CARE AND MAINTENANCE

Care and maintenance10

OPERATING TIPS

Operating tips12

TROUBLESHOOTING GUIDE

Troubleshooting tips14

⚠ CAUTION

- Contact an authorised service technician for repair or maintenance of this unit.
- This product shall be installed by a suitably qualified installation technician.
- This appliance is not intended for use by persons (including children) with reduced physical, sensory or mental capabilities, or lack of experience and knowledge, unless they have been given supervision or instruction concerning use of the appliance by persons responsible for their safety.
- Young children should be supervised to ensure that they do not play with the air conditioner.
- If the power cord needs replacement, this work must be performed by authorised personnel only.
- Installation must be carried out in strict accordance with all local and national wiring standards by authorised personnel only.

DISPOSAL: Do not dispose of this product as unsorted municipal waste. Special, separate collection of this type of product is necessary.

It is prohibited to dispose of this appliance in domestic household waste. For disposal, consider the following possibilities:



- A) The municipality has established collection systems, where electronic waste can be disposed of at least free of charge to the user.
- B) As this product contains valuable resources, they can be recycled and sold to scrap metal merchants or dealers.

Uncontrolled disposal of waste in forests and landscapes endangers your health when potentially hazardous substances leak into the ground-water and find their way into the food chain.





SAFETY PRECAUTIONS

To prevent injury to the user, other people and/or property damage, the following instructions must be followed. Incorrect operation due to ignorance of instructions may cause harm or damage. The seriousness is classified by the following indications.

 WARNING	This symbol indicates the possibility of death or serious injury.
 CAUTION	This symbol indicates the possibility of injury or damage to property.

■ Meanings of symbols used in this manual are as shown below.

	Never do this.
	Always do this.

WARNING

- ⓘ Connect to the power supply correctly.**
 - Incorrect connection may cause electrical shock or fire due to overheating.
- ⓘ Do not start or stop the unit by switching on or off at the power point.**
 - It may cause electric shock or fire due to overheating.
- ⓘ Do not use damaged or unspecified power cords.**
 - It may cause electric shock or fire.
- ⓘ Do not modify power cord length or share the outlet with other appliances**
 - It may cause electric shock or fire due to overheating.
- ⓘ Do not operate with wet hands or in damp environment.**
 - It may cause electric shock.
- ⓘ Do not force airflow directly onto room occupants.**
 - This may affect your health.
- ⓘ Earth the product properly.**
 - Insufficient earthing may cause electric shock.
- ⓘ Keep water away from any electrical components.**
 - It may cause a failure with the unit, or electric shock.
- ⓘ Always install a circuit breaker and a dedicated power circuit.**
 - Intermingled installation may cause fire or electric shock.
- ⓘ Disconnect the power if strange sounds, smell, or smoke are present.**
 - It may cause fire and electric shock.
- ⓘ Do not drink condensate water from the unit.**
 - It may contain contaminants and make you sick.
- ⓘ Do not open the unit when in operation.**
 - It may cause electric shock.
- ⓘ Use the correctly rated circuit breaker or fuses.**
 - There is risk of fire or electric shock.
- ⓘ Do place the power cord close to other heating appliances.**
 - It may cause fire and electric shock.
- ⓘ Do not disassemble or modify unit.**
 - It may cause failure and electric shock.
- ⓘ Ventilate room before operating air conditioner if there is a gas leak from another appliance.**
 - It may cause explosion, fire or burns.
- ⓘ Do not place the power cord near flammable gases or combustibles, such as petrol, thinner or cleaning fluids**
 - It may cause explosion or fire.

SAFETY PRECAUTIONS

CAUTION

- ⓘ When the air filter is being removed, do not touch the metal parts of the unit.**
 - It may cause injury.
- ⓘ Do not put place any objects in the air discharge of the unit.**
 - It may cause damage to the rotating fan.
- ⓘ Ventilate the room when used near gas appliances etc...**
 - An oxygen shortage may occur.
- ⓘ When cleaning the unit, switch off, and isolate at the circuit breaker.**
 - Do not clean unit when power is on as it may cause fire, electric shock or injury.
- ⓘ Do not place unit where air flow is directed onto pets or plants.**
 - It may adversely affect the pet or plants.
- ⓘ Do not use for any other purposes other than intended purpose**
 - Do not use this unit to preserve precision devices, food, pets, plants, or art objects. It may cause deterioration.
- ⓘ Turn unit off in electrical storms or severe weather.**
 - There is a risk of water ingress and electrical failure.
- ⓘ Do not place obstacles around air-inlets or inside of air-outlet.**
 - It may cause failure of appliance or injury.
- ⓘ Turn off at the mains when not using for extended periods.**
 - It may cause failure of the product or fire.
- ⓘ Do not use strong detergents such as spirit or thinners. Use a soft cloth for cleaning.**
 - Product appearance and/or integrity may deteriorated due erosion and/or scratching of the product.
- ⓘ Ensure that any installation brackets are not damaged due to prolonged exposure to the elements.**
 - If the bracket is damaged, there may be a risk of the product falling.
- ⓘ Always insert the filters securely. Clean filter regularly.**
 - Operation without filters or with blocked filters may cause failure.
- ⓘ Do not place heavy objects on the power cord. Take care not to damage or compress the cord.**
 - There is danger of fire or electric shock.
- ⓘ Use caution when unpacking and installing this product.**
 - Sharp edges may cause injury
- ⓘ If water enters the unit, turn the unit off, disconnect the power and contact a qualified service technician for inspection.**
- Do not spray or clean the unit with water.**
 - Water may enter the unit and cause a failure. It may also cause an electric shock.

Indoor unit

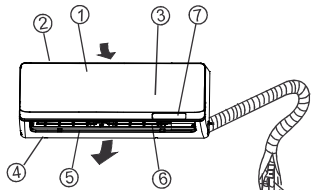

Indoor unit

1. Front panel
2. Air inlet
3. Air filter (Behind front panel)
4. Air outlet
5. Horizontal air flow grille
6. Vertical air flow louver (internal)
7. Display window

Outdoor unit

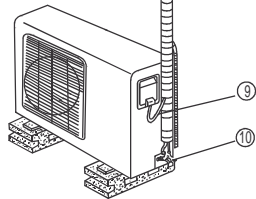



Outdoor unit

8. Interconnecting refrigerant pipe (supplied by installer)
9. Interconnecting wiring cable (supplied by installer)
10. Stop valve

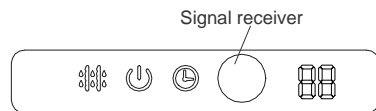
LED Display Window



 **DEFROST** indication lamp
Lights up when the units enters the defrost cycle automatically or when the warm air control feature is activated in heating mode.

 **OPERATION** indicating lamp
This lamp is illuminates when the air conditioner is operating.

 **TIMER** indicating lamp
Lit during Timer operation.

 **Temperature indicator**

- Displays the temperature settings when the unit is operating.
- Displays the troubleshooting fault codes.

NOTE:

The pictures in this manual are for explanation purposes only. Your air conditioner may differ slightly.

Special functions

Refrigerant Leak Detection

With this technology, the LED display window will display "EC". The indicating lamp will continue to flash when the outdoor unit detects a potential refrigerant leak.

Louver Angle Memory Function

Upon restarting the unit, the angle of the horizontal louver will automatically return to the same position set last time.

In the following circumstances, the louver will return to the standard angle:

- 1) Pressing the turbo function or manual control button.
- 2) Turning power off and on to unit
- 3) Unplugging the unit (if applicable)

Self Clean Function

- This function operates after the unit has been in cooling mode to clean the Evaporator and keep it fresh for the next operation.
- The unit will operate in the following sequence :
 - 1 - FAN ONLY mode at Low fan speed
 - 2 - HEATING mode at Low fan speed
 - 3 - FAN ONLY operation
 - 4 - Stop Operation
 - 5 - OFF.

Note:

- This function is only available in COOL (AUTO COOL, FORCED COOL) and DRY modes. Before selecting this function, it is recommended to run the unit in Cooling mode for approximately 30 minutes. Once the Self Clean function is activated, all TIMER settings will be cancelled.
- In Self Clean mode, if the SELF CLEAN button on the remote control is pressed, the unit will stop and turn off automatically.

Vertical Swing Function

When the unit is turned on, the users can control the swing of the vertical louver swing by the button on the remote control.

NOTE: This manual does not include information regarding the Remote Control, please see the Remote Control Manual, which is packed with the indoor unit.

Operating temperature limits

Temperature \ Mode	Cooling	Heating	Drying
Room temperature	17°C	30°C	10°C
Outdoor temperature	0°C ~ 50°C	-15°C ~ 30°C	0°C ~ 50°C

NOTE:

- Optimum performance is achieved within these operating temperature limits. If the unit is used outside the above limits/conditions, certain safety protection features may be brought into operation and cause the unit to not function as intended.
- Room relative humidity must be less than 80%. If the unit operates in an environment in excess of this value, the surface of the unit may attract condensation. In this case, please set the vertical air flow louver to its maximum angle (vertically to the floor), and set the fan speed to HIGH.

Manual operation

Manual operation can be used temporarily in case the remote control is disabled or the unit requires service/maintenance.

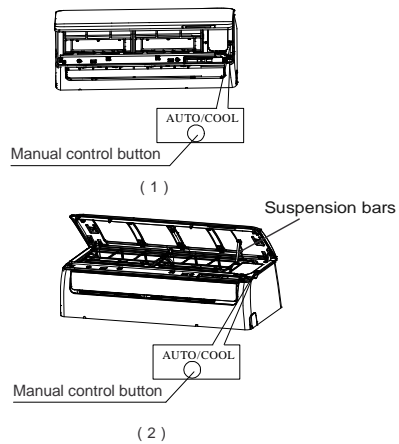

NOTE: The unit must be turned off before using the manual control button. If the unit is operational, hold down the manual control button until the unit is off.

- Open and lift the front panel up at an angle until it clicks and remains in place.
- One press of the manual control button will start forced AUTO operation. If pressed twice within five seconds, the unit will operate under forced COOL operation.
- Close the panel firmly to its original position.

CAUTION:

This button is used for testing purposes only. Do not use it for normal operation. To restore to the remote control operation, use the remote control directly.

Airflow direction control

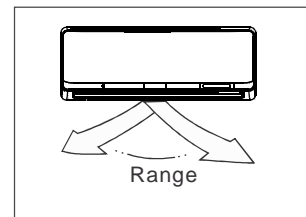
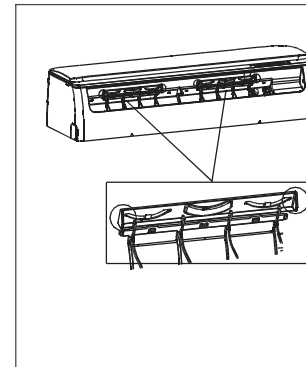
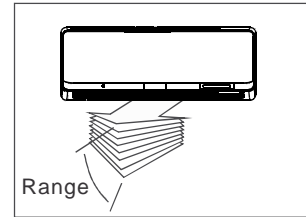

Adjust the air flow direction as required so as not to cause discomfort to the occupant or cause uneven room temperatures. Adjust the horizontal/vertical louvers using the remote control.

To set the horizontal/vertical air flow direction

- Perform this function while the unit is in operation.
- Use the remote control to adjust the air flow direction. The vertical/horizontal louvers change 6 degrees in angle for each press of the button. The louver can also be set to swing automatically.
- Please refer to the Remote Control Manual for details.

WARNING:

IMPORTANT: Please do not insert your fingers or other objects into the unit. The rotating supply air fan inside may cause damage or injury.

CAUTION

- Do not operate the unit for extended periods with the air flow direction set downward in cooling or dehumidifying mode. Condensation may form on the surface of the horizontal louver causing moisture to fall from the unit.
- When the unit is restarted immediately after being turned off, the louvers may not respond for up to 10 seconds as they reset their position.
- The angle of the horizontal louver should not be set at an overly acute angle, as this may reduce performance as a result of restricted air flow.
- The horizontal louver should not be positioned by hand. This will force the horizontal louver out of sync. If this occurs, please isolate the power supply for 10 seconds, then restart the unit.
- Do not operate the unit with horizontal louver in the closed position, this will cause a malfunction due to restricted air flow.

How the air conditioner works

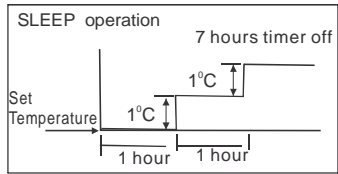

Cooling

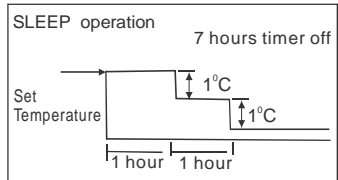

Heating

AUTO operation

- When you set the unit in AUTO mode, it will automatically select cooling, heating or fan only operation depending on the set point temperature and the room temperature.
- The unit will maintain the room temperature automatically to the temperature you set.
- If you feel uncomfortable in the AUTO mode, you may manually set your desired temperature.

SLEEP operation

- When you push the SLEEP button on the remote control during cooling, heating or AUTO operation, the unit will automatically increase (Cooling) or decrease (Heating) the set point by 1°C per hour for the first 2 hours, then hold the set point steady for the next 5 hours, then turn the unit off.
- This mode saves energy and running costs and improves comfort levels at night.

DRYING operation

- The fan speed is automatically controlled under the drying operation.
- During drying operation, if the room temperature is lower than 10°C, the compressor is switched off and is restarted once the room temperature rises above 12°C.

Optimal operation

To ensure optimal performance, please bear in mind the following:

- Adjust the air flow direction correctly so that it is not forced directly onto people.
- Adjust the temperature to achieve the best comfort level. Do not set the unit to excessively high or low temperature levels.
- Close all doors and windows in COOL or HEAT modes, to ensure optimal performance.
- Use TIMER ON button on the remote control to select a time you want to start your unit.
- Do not place any objects near the air inlets or outlets, as this will affect the efficiency of the unit and may cause it to stop.
- Clean the air filter regularly, otherwise cooling and heating performance will be adversely affected.
- Do not operate unit with horizontal louvre in the closed position.

Care and Maintenance

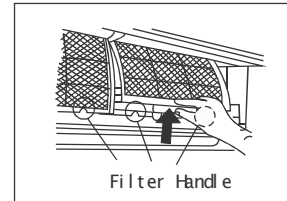
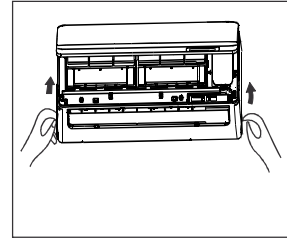

Filter Handle

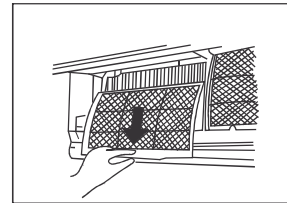

Cleaning the Grille, Case and Remote Control

Turn the system off before cleaning. To clean, wipe with a soft, dry cloth. Do not use bleach or abrasives.

NOTE: Power supply must be disconnected before cleaning the indoor unit.

CAUTION

- A cloth dampened with cold water may be used on the indoor unit if it is very dirty. Then wipe down with a dry cloth.
- Do not use chemically treated cloths or dusters to clean the unit.
- Do not use thinners, polishing powder, or similar solvents for cleaning. These may cause the plastic surface to crack or deform.
- Never use water hotter than 40°C to clean the front panel, it may cause deformation or discoloration.

Cleaning the air filter

NOTE: Power supply must be disconnected before cleaning the indoor unit.

A clogged AIR FILTER reduces the efficiency of the unit. Please clean the AIR FILTER regularly.

1. Lift the indoor unit panel up to an angle until it clicks and remains open. Some models have suspension bars to prop open the panel.
2. Take hold of the air filter handle and lift it up slightly to remove it from the filter holder, then pull the filter downwards.
3. Remove the AIR FILTER from the indoor unit. Clean the AIR FILTER with a vacuum cleaner or clean water, then allow to dry in cool place.

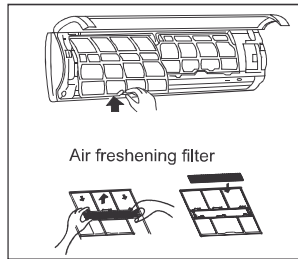

Air freshening filter

4. Remove the air freshening filters (if applicable) from the supporting frame. Clean them with clean water or a vacuum cleaner, allow them to dry in a cool place.
5. Install the air freshening filter back into position.
6. Insert the upper portion of air filter back into the unit, taking care that the left and right edges line up correctly and place filter into position.

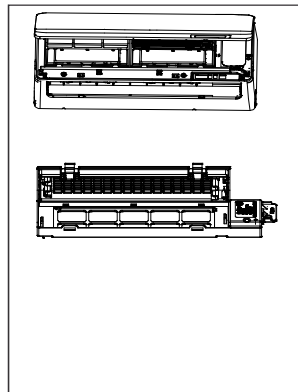

Maintenance

If you plan to not use the unit for a long time, perform the following procedure:

- (1) Clean the indoor unit and filters.
 - (2) Operate the fan for approximately 3 - 4 hours to dry the inside of the unit.
 - (3) Turn off the unit and disconnect power.
 - (4) Remove the batteries from the remote control.
- The outdoor unit requires periodic maintenance and service. Do not attempt this yourself, it can only be performed by suitably qualified personnel. Contact Brivis 1300 BRIVIS, 1300 274847.

Checks before restarting operation

- Check that the wiring is complete and not disconnected.
- Clean the indoor unit and filters.
- Check that the air filter is installed.
- Check that the outlets and inlets are not blocked if the unit has not been used for a long time.

⚠ Caution

- Do not touch the metal parts of the unit when removing the filter. Injuries can occur when handling sharp metal edges.
- Do not use water to clean inside the unit. Exposure to water can damage components and lead to possible electric shock.
- When cleaning the unit, first make sure that the power and circuit breaker are turned off.
- Do not wash with hot water at more than 40°C. Make sure the unit is completely dry before operating. Do not expose filters to direct sunlight, filter may shrink.

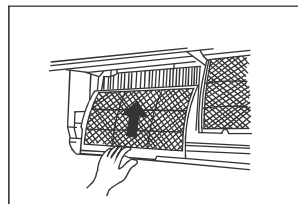
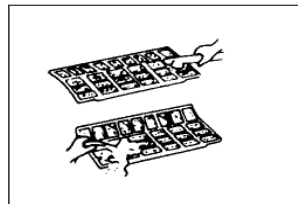

The following events may occur during normal operation.

1. Protection of the air conditioner.

Compressor protection

- The compressor is prevented from restarting for 3 minutes after it switches off.

Anti-cold air

- The unit is designed not to blow cold air on HEAT mode, when the indoor heat exchanger is in one of the following three scenarios and the set temperature has not been reached.
 - A) When heating has just started.
 - B) When the unit is in Defrost mode.
 - C) Low temperature heating (where applicable).
- The indoor and/or outdoor fans stop when in defrost mode.

Defrosting

- Frost may accumulate on the outdoor coil during heating mode when the outdoor temperature is low and humidity is high, resulting in a lower heating efficiency.
- In these conditions, the unit will stop heating and enter the defrost mode automatically.
- The defrost period may vary from 4 to 10 minutes depending on the outdoor temperature and the amount of frost built up on the outdoor coil.

2. A white mist coming out from the indoor unit

- A white mist may be generated if there is a large temperature difference between air inlet and outlet in COOL mode, and if the indoor environment that has a high relative humidity.
- A white mist may be generated due to moisture expelled during the defrosting cycle, when the unit restarts in HEAT mode.

3. Low noise of the air conditioner

- You may hear a low hissing sound when the compressor is running or has just stopped running. It is the sound of the refrigerant equalising or coming to a stop.
- You can also hear a low sound when the compressor is running or has just stopped running. This is caused by heat expansion and cold contraction as the unit temperatures change.
- A small noise may be heard as the louvers return to their original position when power is turned on.

4. Dust is blown out from the indoor unit.

This is a normal condition when the unit has not been used for a long time or during initial start up of the unit.

5. A peculiar odour emanates from the indoor unit.

The indoor unit is recirculating odours that are permeated from building materials, furniture, pets, food, people or smoke.

6. The air conditioner turns to FAN only mode from COOL or HEAT mode.

When indoor temperature reaches the temperature set point, the compressor will turn off automatically, and the unit will enter FAN only mode. The compressor will start again when the indoor temperature rises sufficiently in COOL mode or falls sufficiently in HEAT mode compared to the set point.

7. The air conditioner runs Anti-mildew function (if applicable) after turning off the unit.

When turning off the unit under COOL(AUTO COOL, FORCED COOL) and DRY mode, the unit will run the Anti-mildew function for 7-10 minutes, then stop the operation and turn off the unit automatically.

OPERATING TIPS

8. Moisture may condense on the surface of the indoor unit when cooling in a high relative humidity condition (relative humidity higher than 80%). Adjust the horizontal louver to the maximum air outlet position and turn the fan to HIGH speed.
9. **Heating mode**
The air conditioner draws in heat from the outdoor unit and releases it via the indoor unit during heating operation. When the outdoor temperature falls, heat drawn in by the unit decreases accordingly. At the same time, heat load on the unit increases due to larger difference between indoor and outdoor temperature. If a comfortable temperature can't be achieved by the unit, it is either sized incorrectly or not running efficiently. Check the operation of the unit fully.
10. **Auto-restart function**
Power failure during operation will stop the unit completely.
For units with the Auto-restart feature, when the power is restored, the unit restarts automatically with all the previous settings preserved by the internal memory of the unit.
11. Lightning, radio communications or wireless telephones operating nearby may cause the unit to malfunction due to electronic interference.
Disconnect the unit from the power and then re-connect the unit and turn the power back on.
Push the ON/OFF button on the remote control to restart the unit.

TROUBLESHOOTING GUIDE

Troubleshooting Tips

If one of the following faults occurs, stop the unit immediately, turn off the power and then turn power back on again. If the problem still exists, turn the power off and contact BRIVIS on 1300 BRIVIS - 1300 274847 for assistance.	
Trouble	OPERATION indicator or other indicators continue flashing.
	Fuse blows frequently or circuit breaker trips frequently.
	Foreign objects or water enters the unit.
	The remote control doesn't work or works abnormally.
If one of the following codes appears on the display area : E0,E1,E2,E3.....or P0,P1,P2,P3.....	

Malfunction	Cause	What should be done?
Unit does not start	Power black out	Wait for power to be restored.
	Unit may have been disconnected or unplugged	Check that power plug is securely plugged into the wall socket
	Fuse may have blown.	Replace the fuse.
	Batteries in the Remote control may be flat.	Replace the batteries.
	The time you have set with timer is incorrect.	Wait or cancel timer setting.
Unit not cooling or heating room sufficiently while the fan is operating	Inappropriate temperature setting.	Set temperature correctly. For detailed method please refer to "Using remote control" section.
	Air filter is blocked.	Clean the air filter.
	Doors or windows are open.	Close the doors or windows.
	Air inlet or outlet of indoor or outdoor unit has been blocked.	Clear obstructions away first, then restart the unit.
	Compressor 3 minute protection has been activated.	Wait.

If the symptom(s) persist, please contact BRIVIS on 1300 BRIVIS, 1300 274847 for assistance.
Please have a detailed description of the issue, along with the model & serial numbers or your unit ready.

Notes: Do not attempt to repair the unit yourself.

Please contact BRIVIS on 1300 BRIVIS, 1300 274847 for assistance.