

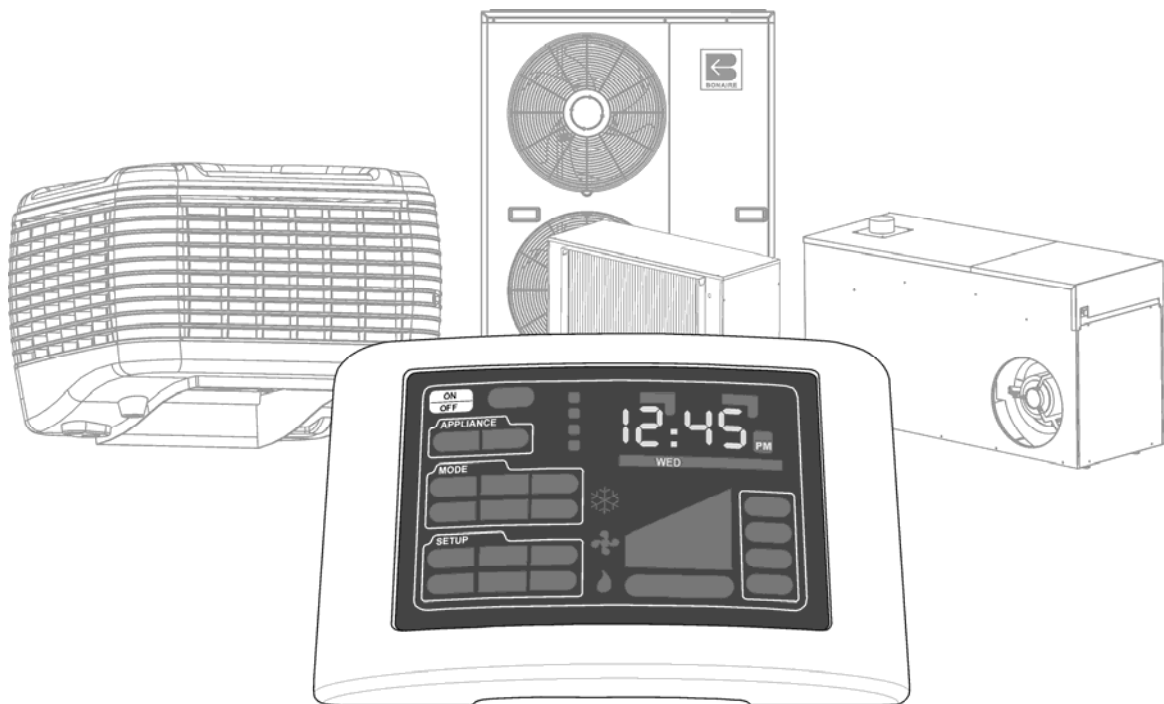

Using the
Ducted Gas Central Heating
Dual Cycle Refrigerated Air Conditioning
Ducted Evaporative Air Conditioning
with your
multi-appliance
Touch Pad Control



Owner's Manual

Please keep this important manual in a safe place. It is the owner's responsibility to ensure that regular maintenance is carried out on this ducted heating / cooling product. Failure to do so will void all guarantees beyond statutory and legal requirements.

www.climatetechnologies.com.au



Contents

INTRODUCTION.....5

GENERAL INFORMATION.....6

Important Installation Notice.....6

Data Location.....6

NAVIGATING THE CONTROLS.....7

QUICK START - SIMPLE MANUAL OPERATION8

ON / OFF.....8

APPLIANCE - selecting the desired appliance.....8

MODE - operating your appliance in your preferred mode.....9

SETUP - setting up or reviewing various functions.....10

Child Lock.....10

Temperature / Time Toggle.....10

Zones – where zone motors are fitted.....10

Adjustment Arrows.....11

Reset / Fault Code.....11

Icons.....11

DUCTED GAS CENTRAL HEATING.....12

GENERAL INFORMATION.....13

Important Notice.....13

Data Location.....13

Assembly.....13

SAFETY.....14

Safety & Owner Responsibility.....14

Precautions.....14

Features.....14

Power or Gas interruption.....14

USING YOUR TOUCH PAD WITH DUCTED GAS CENTRAL HEATING.....15

THERM Operation (Thermostat).....15

ECONOMY & BOOST for heating.....16

FAN.....16

ZONES.....17

Setting the open or closed status.....17

Programming Your Touch Pad.....17

Using The Program Mode (PGRM).....19

Program Override (PGRM).....19

Clock Setup.....20

Summer Shutdown (Optional).....20

First Startup Or Restart After Shutdown.....20

DUCTED GAS HEATING MAINTENANCE.....21

General Maintenance.....21

Scheduled Maintenance.....21

PROBLEM SOLVING.....22

DUAL CYCLE REFRIGERATED AIR CONDITIONING.....23



Contents

GENERAL INFORMATION 24

Important Notice..... 24

Data Location 24

Assembly 24

SAFETY 24

Safety & Owner Responsibility..... 24

Precautions..... 24

Features..... 24

Power interruption 24

Manual Operation 25

ZONES - Selecting ZONE 1, 2, 3, or 4..... 26

Programming Your Touch Pad..... 26

Programming Sequence 26

DUCTED EVAPORATIVE AIR CONDITIONING 27

 INTRODUCTION 28

Exhaust..... 28

Water Management..... 29

 OPERATING THE TOUCH PAD..... 30

Cool Mode..... 30

Boost Mode..... 30

Thermostat Mode..... 31

Program Mode 31

Program Setup..... 32

Clock Setup..... 33

 DUCTED EVAPORATIVE AIR CONDITIONER MAINTENANCE 34

General 34

Filter Pads..... 34

Water Tank 34

Water Level / Float Valve..... 34

Motor and Fan..... 35

Electrical 35

Bleed Off..... 35

Pump..... 35

Water Distribution 35

No Seasonal Maintenance..... 35

 TROUBLE SHOOTING GUIDE 36

CONTROL SETUP 37

 SETTING UP THE CONTROL - GENERAL 37

Before Starting..... 37

Installation..... 37

 USING THE SETUP MODES 38

Product Identification..... 38

 CODING..... 39

Auto-Coding..... 39



Contents

Coding Defaults 39
Forced Scan Auto-Coding:..... 39
Important Notes 39
 MULTIPLE UNIT SETUP – HEATER / COOLER..... 40
 Force Coding a New / Additional Product 40
 Fault Codes Access 41
 View The Fault Code..... 41
 Fault Codes For High Efficiency, Mid Efficiency Heaters 42
 Resetting the Touch Pad Control 43
 Calibrating the Thermostat 43
 EVAPORATIVE AIR CONDITIONING SETUP 44
 Setting the Water Management Systems Parameters and values 44
 Setting the Water Level & Bleed rate 45
 Fan Speed Settings 46
 MULTIPLE UNIT SETUP – EVAPORATIVE COOLERS 47
 Setting the Common Zone For Multiple Units 48
 Scan For Products: 48
 DUCTED GAS CENTRAL HEATING..... 49
 Setting Fan SPEEDS – High / Low 49
 Setting Fan Speeds - Zoning 50
 Setting the Zone Availability - Heating 51
 COMMISSIONING CHECK LIST 53
 General 53
 Unit – Ducted Heating..... 53
 Unit – Dual Cycle Refrigerated Air Conditioning 53
 Unit - Ducted Evaporative Air Conditioner 54
 Ductwork..... 54
 Site..... 54
 Customer Hand Over..... 54
 WARRANTY 55
 SERVICE..... 59

Text and Illustration Copyright Climate Technologies 2008

All rights reserved. No part of this document may be reproduced or transmitted in any form or by any means, electronic or mechanical, including photocopying, recording or by any information storage and retrieval system, without prior permission in writing from Climate Technologies

In the interest of continued product improvement Climate Technologies reserves the right to alter specifications without notice. E.&O.E.



Introduction

You have chosen one of the world's most advanced control systems incorporating the latest technology.

The Touch Pad control is an Australian and world first for its use with ducted heating and cooling systems. Designed exclusively for Climate Technologies air comfort products, the self-prompting display panel controls your unit's functions, providing the ultimate in heating and cooling flexibility.

This technologically advanced controller comes with manual and thermostat control, programmable timer, boost function plus many other setup functions.

Your Touchpad Control has been designed to operate the following Climate Technologies products:

Heating – 3, 4, 5 Star Ducted Gas Central Heaters.

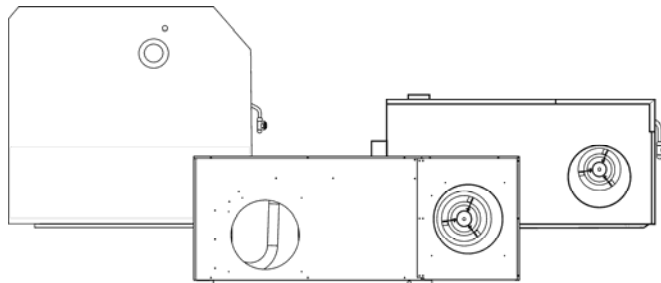

Dual Cycle Cooling - Refrigerated Air Conditioning (cooling only) designed to Dual Cycle to Ducted Gas Central Heaters.

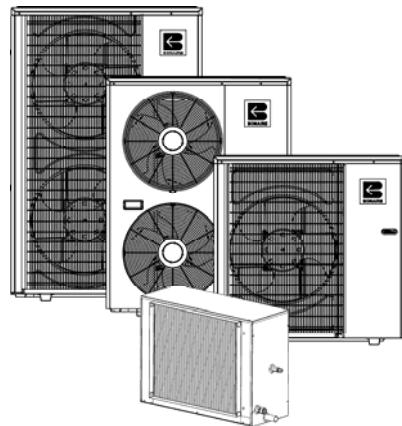

Fresh Air Conditioners - Ducted Evaporative Air Conditioners.

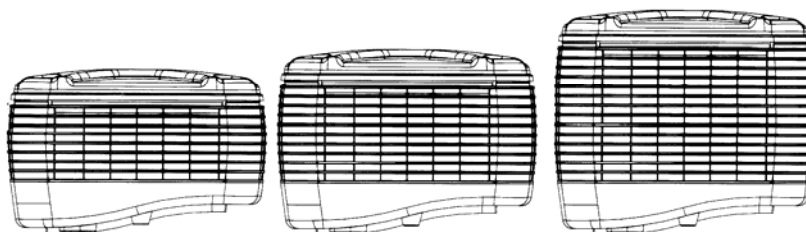



Introduction

Your Touch Pad Control is designed to automatically detect the appliances during the commissioning of the unit by the installer. Controller options not required for your appliances will usually not be visible on your Touch Pad display.

Additional control accessories that can be added to your Touchpad control for enhanced operation include:

Remote Thermostat – an extra thermostat that can be connected in conjunction with the Touchpad to individually control a zone motor in a specified area of a ducted gas heating system.

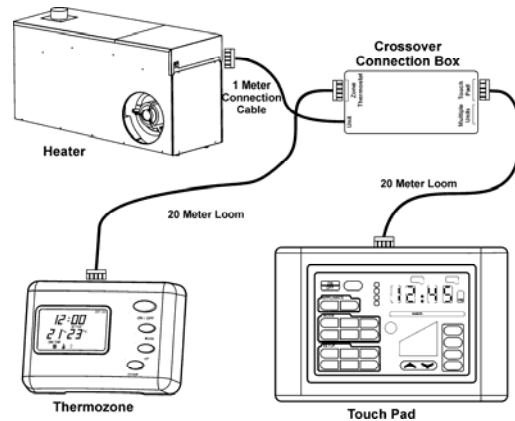

Home Automation – allows the unit to be turned ON or OFF through most home security systems.

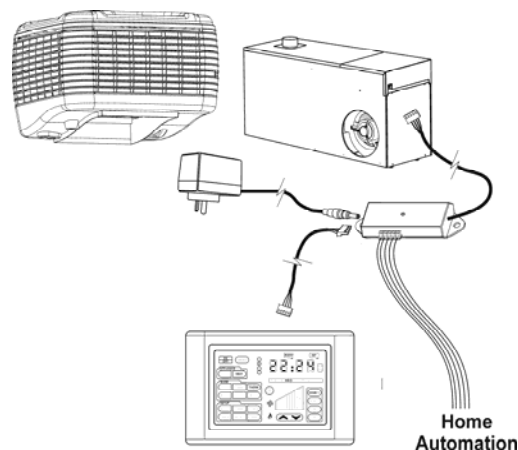

Your Touch Pad is designed in Australia to suit Australian conditions and will ensure that your home is comfortable all year round.

GENERAL INFORMATION

IMPORTANT INSTALLATION NOTICE

A licensed person is required to install Climate Technologies equipment. If the equipment is not installed in accordance with the installation instructions and the governing body regulations, Climate Technologies reserves the right to refuse service on non compliant installations.

Subject to state regulations and by laws a certificate of compliance must be issued for the electrical and plumbing connections certifying that the work complies with all the relevant standards.

Note: Only a licensed person will have insurance protecting their workmanship.

DATA LOCATION.

Your appliance model number, serial number and model description are located on the appliance data plate on the end of the heater or inside the cooler in the vicinity of the electronic controls. These details should also be in the warranty section of this booklet.

You will need this information, should your appliance require servicing, spare parts or just if you require additional information about this product.



Navigating the Controls

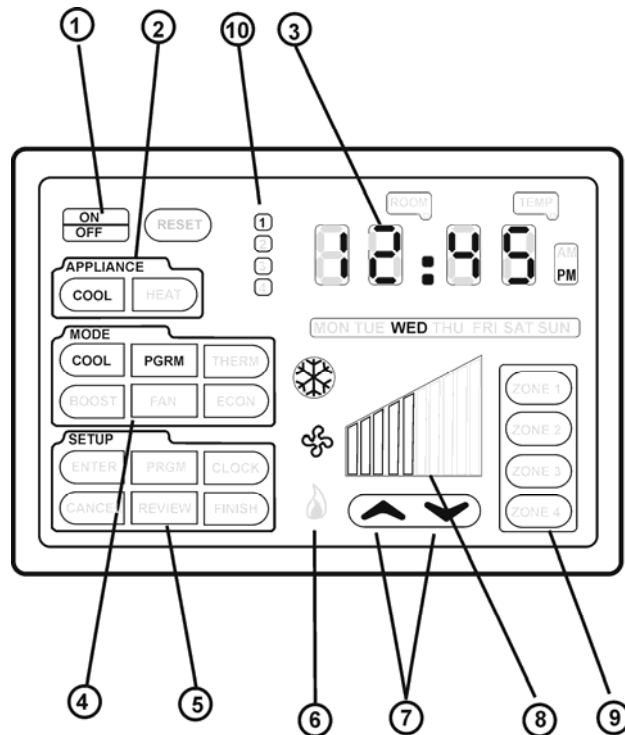

| Number | Description | Function |
|--------|---------------------|--|
| 1 | ON / OFF | Turns the unit ON or OFF |
| 2 | APPLIANCE | Touch any area within the APPLIANCE outline to select product. |
| 3 | CLOCK / TEMPERATURE | 12 hour clock denoting AM / PM and the day OR room and SET temperature for HEATING and DUAL CYCLE cooling mode. |
| 4 | MODE | Touch any area within the MODE outline and the available operating modes will be displayed. |
| 5 | SETUP | Touch any area within the SETUP outline and the available setup icons will be displayed. |
| 6 | FUNCTION SYMBOLS | Symbols indicate the unit components functioning. |
| 7 | UP / DOWN ARROWS | Arrows will adjust the output of the unit. |
| 8 | FUNCTION LEVEL | Function level displays the output level settings with graphic bars |
| 9 | ZONES | Controls zones for Ducted Gas Heating / Dual Cycle Air Conditioning. Where there is more than one unit fitted the zones buttons can control the ON / OFF function of one or more units. Each unit is then treated as a zone. |
| 10 | PERIOD | In PRGM mode there are 4 operating periods available. The 1, 2, 3, 4 advises which operating period the program is in. |



Navigating the Controls

Quick Start - Simple Manual Operation

Here's all you have to do to get going (if the installer hasn't already done it for you).

Step 1 Turn the control ON at the ON / OFF button.



Step 2 Select the Appliance if not already selected in the APPLIANCE area.

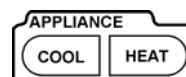

Step 3 Select the MODE of operation required by pressing anywhere within the MODE area.

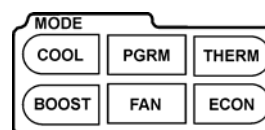

(The icon availability will vary according to the Appliances selected. See display options below)

Press the required mode so the selection is solid. The remaining icons will flash 5 more times and disappear.

Step 4 Use the  arrows to vary the unit output.

Refer next page for more details.

ON / OFF

When pressing the ON / OFF button to turn the unit on, the touch pad control will return to the last used setting.



APPLIANCE - SELECTING THE DESIRED APPLIANCE

Press any area within the Appliance outline for the available appliances.

- If only one appliance type is fitted the control will BEEP.
- If more than one appliance type is installed the COOL and HEAT icons will flash. Make your selection by pressing the required product icon. Once selected the icon will become solid. The remaining icon will continue to flash a further 5 times then disappear.

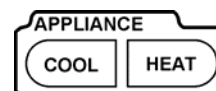

When the touchpad is turned on the last appliance used will be activated.

This control is capable of controlling the following Climate Technology products installed with PNE control systems:

- Ducted Gas Central Heating
- Dual Cycle Ducted Gas Central Heating and Dual Cycle Refrigerated Air Conditioning
- Ducted Evaporative Air Conditioning
- Ducted Gas Central Heating and Ducted Evaporative Air Conditioning.



Navigating the Controls

Mode / Icon Options

To view the MODE options available press the touch pad anywhere within the MODE outline. The available functions will be dependent on the products installed.

Ducted Gas Heating

Available Icons HEAT Appliance
(Ducted Gas)

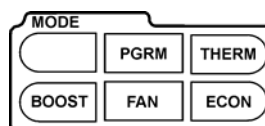

Ducted Evaporative A/C

Available Icons COOL Appliance

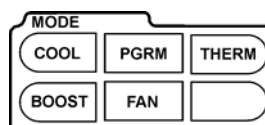

Dual Cycle Refrigeration A/C

Available Icons COOL Appliance

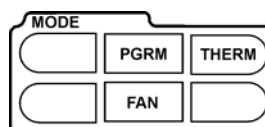

MODE - OPERATING YOUR APPLIANCE IN YOUR PREFERRED MODE

- COOL – *Evaporative Air Conditioning Only*
Fan and Pump in manual mode. This means the fan can be adjusted manually via the UP / DOWN arrows and the pump operates continuously.
- BOOST – *Ducted Gas Central Heating and Evaporative Air Conditioning Only*
The room air fan will operate at maximum speed.
- PGRM - *Ducted Gas Central Heating, Evaporative Air Conditioning, Dual Cycle Air Conditioning*
The unit can be set up in Program Mode to turn the unit ON and OFF in the desired mode.
For ducted heating and dual cycle refrigeration this is a 7-day program.
For ducted evaporative air conditioning this is a 1-day (24-hour) program.
- FAN – *Ducted Heating and Evaporative Air Conditioning.*
Fan only in manual mode. This means the fan only can be run and adjusted via the UP / DOWN arrows.

In dual cycle cooling mode the fan will run continuously while the condenser cycles ON and OFF
- THERM – *Ducted Gas Central Heating, Evaporative Air Conditioning, Dual Cycle Air Conditioning*
Thermostat mode will control the unit via a temperature sensor located inside the touchpad itself.

Set the comfort level and the unit will automatically increase or decrease the amount of heating or cooling required according to demand.
Adjust the comfort level using the UP / DOWN arrows
- ECON – *Ducted Gas Central Heating Only*
Economy will run a ducted gas central heater at the lowest available fan speed and gas setting. This is best used once the space has been brought up to temperature.



Navigating the Controls

SETUP - SETTING UP OR REVIEWING VARIOUS FUNCTIONS

To view the SETUP options available, press the touch pad anywhere within the SETUP outline. The available functions are:

- PGRM – Program setup allows you to create a timed program to start and stop the product. There are 4 period programs available requiring a minimum of 2 to be set per day.

For ducted evaporative air conditioning the program option will only function for 24 hours and then the unit will stop.

- CLOCK – Setting the time
- REVIEW – Pressing the review button will automatically step the control through the timer programs set.

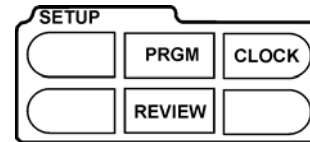

CHILD LOCK

This function is designed to be a simple mechanism to lock the control to prevent unnecessary adjustments to the system. When the lock is engaged there will be no system functions available. (This is available in either on or off modes)

- To engage the Child Lock press and hold anywhere over the numeric display for 4 seconds. A BEEP followed by a BEEP will be heard to indicate the lock is ON.
- To remove the child lock press and hold anywhere over the numeric display for 4 seconds. A Single BEEP followed by another single BEEP will be heard to indicate the lock is OFF.

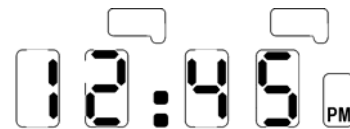

TEMPERATURE / TIME TOGGLE

To change the display between temperature and time just press anywhere in the numeric display. In Evaporative Cooling mode only the time will be displayed.

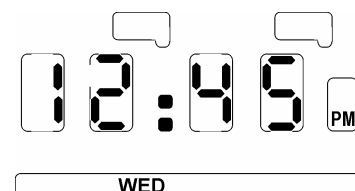

ZONES – WHERE ZONE MOTORS ARE FITTED

The zone motor option is only available with ducted gas heating / dual cycle products. These icons allow zones to be turned ON or OFF. This function will ONLY be made available by the installer if zone motors have been fitted to your duct work.

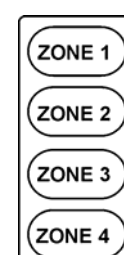



Navigating the Controls

ADJUSTMENT ARROWS

The adjustment arrows can be used to increase or decrease the function of product being controlled. The icons will come on automatically to indicate the unit's mode of operation.

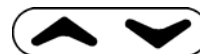

RESET / FAULT CODE

If the reset icon appears and the touchpad thermostat is flashing information in clock area, it means the unit has stopped as the result of a fault e.g. electricity / gas interruption or some other malfunction.



The information being displayed will continually rotate between the unit identification and the fault code e.g. HC: 01 and F: 04. Before resetting the control, note the fault code information. Should a service call be required, this will assist in quick diagnostics and service requirements.

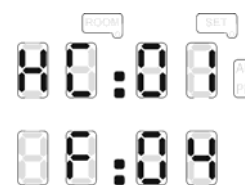

To RESET the unit, press and hold the RESET icon for **approximately 4 seconds** until 2 Beeps have been heard. The reset icon will disappear and your appliance will be reset. If there has been no component failure the unit will now resume its function.

Fault Code Example:-
Product - Central Heater
Fault - Over Temperature

ICONS

The operating icons will be displayed relative to the unit's operation.

1. Indicator Bars

Evaporative Air Conditioning

(Manual Mode) shows fan speed.

(Thermostat Mode) comfort settings.

Central Heaters shows fan speed setting in FAN mode.

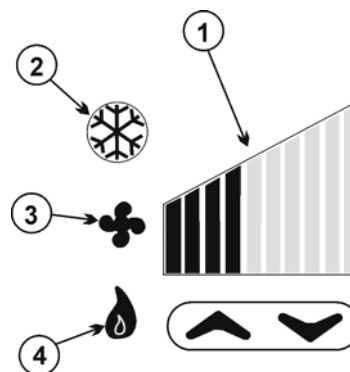

2. Snow Flake Symbol

For evaporative air conditioning it indicates that the pump is on.

or

For Dual Cycle Refrigerated Air Conditioning it indicates that the condenser is operating.

3. Fan Symbol

For Evaporative Air Conditioning it indicates that the fan is operating.

For Ducted Heating it indicates that the fan is operating.

For Dual Cycle Refrigerated Cooling it indicates that the fan is operating.

4 Flame Symbol

Indicates that the thermostat is calling for heat from the ducted central heater

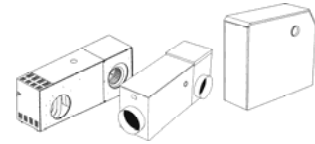

Ducted Gas Central Heating

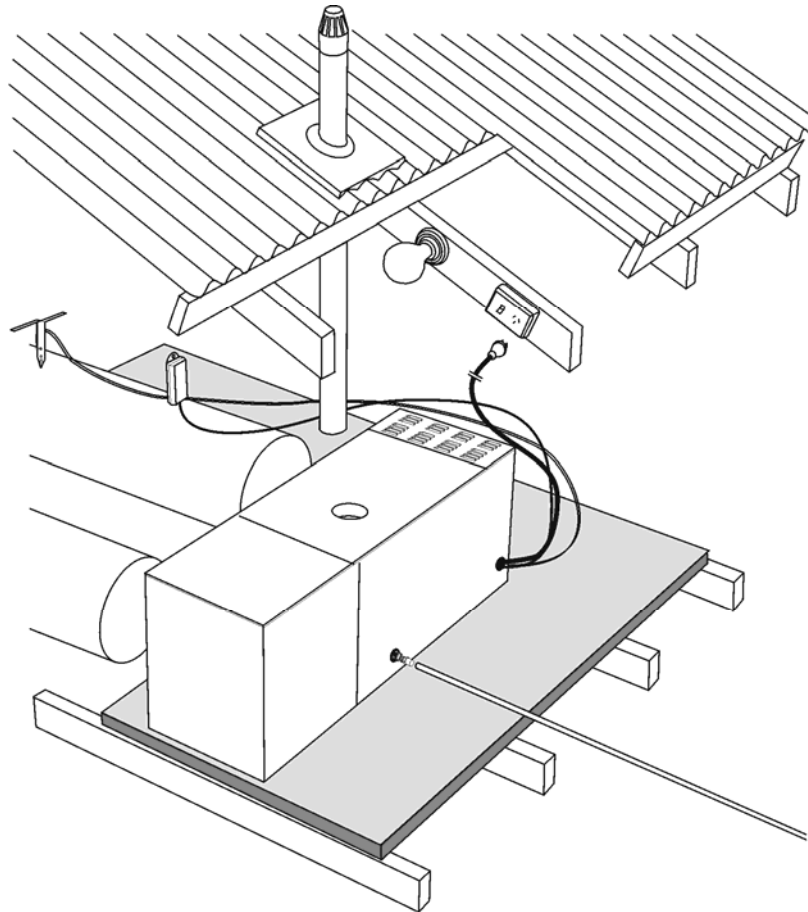

Owner's Operation and Maintenance Details

Please keep this important manual in a safe place. It is the owner's responsibility to ensure that regular maintenance is carried out on this Ducted Gas Central Heater. Failure to do so will void all guarantees beyond statutory and legal requirements.

www.climatetechnologies.com.au

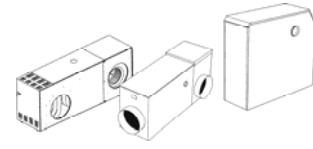

Ducted Gas Central Heating

Congratulations on purchasing this ducted gas central heating system, an exciting new product manufactured by Climate Technologies.

Wholly designed and manufactured in Australia, this Ducted Gas Central Heater represents an exciting new development in warm air furnace design. It embodies the latest advances in gas heating technology.

Your heater is supported by Climate Technologies, Australia's most advanced manufacturer of a complete range of climate control products.

To ensure you fully enjoy the benefits of this Ducted Gas Central Heater, please read these instructions carefully and keep them handy for future reference.

Operated and maintained in accordance with this manual, this unit will provide you with years of warm and environmentally friendly operation. Please take the time to read this manual.

NOTE: The manufacturer and its service providers reserve the right to refuse service unless safety and accessibility to the unit can be guaranteed in accordance with the installation instructions and Australian Standards. The cost of any extra equipment required to provide access to the unit for servicing is the responsibility of the owner.

General Information

IMPORTANT NOTICE

A licensed person is required to install Climate Technologies equipment. If the equipment is not installed in accordance with the installation instructions and the governing body regulations, Climate Technologies reserves the right to refuse service on non compliant installations.

Subject to state regulations and by laws a certificate of compliance must be issued for the electrical and plumbing connections certifying that the work complies with all the relevant standards.

Note: Only a licensed person will have insurance protecting their workmanship.

DATA LOCATION

Your appliance model number, serial number and model description are located on the appliance data plate on the end of the heater or under the lid in the vicinity of the electronic controls. These details should also be in the warranty section of this booklet.

You will need this information, should your appliance require servicing, spare parts or just if you require additional information about this product.

ASSEMBLY

There is no assembly required of this Ducted Gas Central Heater. Your Dealer or installer will carry out all assembly and commissioning upon installation.

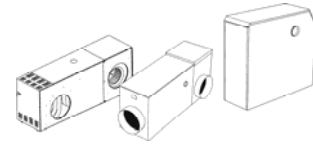

Ducted Gas Central Heating

Safety

SAFETY & OWNER RESPONSIBILITY

The manufacturer and its service providers reserve the right to refuse service unless safety and accessibility to the unit can be guaranteed. The cost of any extra equipment required to provide access to the unit for servicing is the responsibility of the owner.

PRECAUTIONS

DO NOT PLACE ARTICLES ON OR AGAINST THIS APPLIANCE.

DO NOT USE OR STORE FLAMMABLE MATERIALS NEAR THIS APPLIANCE.

DO NOT SPRAY AEROSOLS IN THE VICINITY OF THIS APPLIANCE WHILE IT IS IN OPERATION.

DO NOT PLACE ARTICLES IN FRONT OF OR OVER THE RETURN AIR GRILLE.

FEATURES

Your Ducted Gas Central Heater has all the safety devices to ensure safe operation. These devices conform to the standards set out by the Standards Australia.

POWER OR GAS INTERRUPTION

Should there be an interruption to the power supply during the heating operation the controls will automatically turn off the gas.

The heater will be ready to resume operation once the power has been restored.

Should there be an interruption to the gas supply, the heater will endeavor to re-light 3 times and if unsuccessful will lock out. (This is part of the safety features). Should this occur the heater will need to be reset. If the RESET icon is displayed, press and hold the RESET icon till a BEEP is heard and the unit will be ready to resume operation.

Please refer to your problem-solving chart to assist resolving other problems.

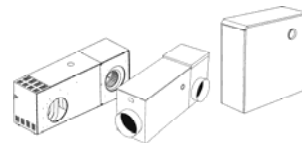

Ducted Gas Central Heating

Using Your Touch Pad with Ducted Gas Central Heating

Using your Touch Pad for manual operation of your Central Heating when you want direct control, without timers or programming.

THERM OPERATION (THERMOSTAT)

Step 1 To turn the Touch Pad on, press and release the **ON/OFF** button. If there is only a central heater **HEAT** will automatically display in the Appliance Outline.

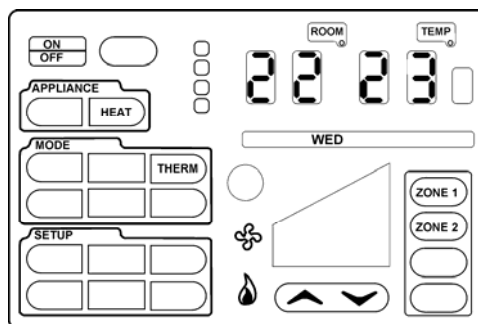

NOTE: Your Touch Pad Control is designed to automatically detect the appliances you have installed. Options not required for your appliances will not be displayed on the touchpad. So don't worry if you don't see all the menu items listed in this book.

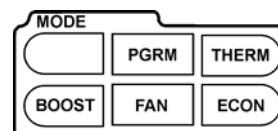

Step 2 Press anywhere within the **MODE** outline.

The available icons will flash. Select **THERM**. The icon will become solid and the remaining icons will flash 5 more times before disappearing.



Step 3 Press the   arrows to increase or decrease the set temperature (TEMP).

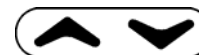

Step 4 Your Touch Pad measures the room temperature using a thermostat inside its case. The Touch Pad will run the Heater until it measures temperature a little above your set temperature and then turn off the unit. When the temperature falls a little below the set temperature the unit will restart. The unit operation will be as follows:

- When the room temperature (ROOM) is colder than the set temperature (TEMP) the heater will come on after approximately a 30 second ignition process
- If at start up the room temperature (ROOM) is 2.0° or more below the set temperature (TEMP), the central heater will start up at high fan speed and high gas rate bring your house up to temperature as quickly as possible.
- As the room temperature gets closer to the set temperature the central heater will reduce the room air fan and the gas rate to the burner.
- When the thermostat reaches the set temperature the central heater will be on low fan and the gas will modulate to low fire.
- When the temperature has gone over the set temperature by 0.5° the central heater will shut down.
- When the temperature has dropped to 1° below set temperature the unit will restart.
- The flame symbol will be displayed on the control to indicate the heater is functioning.

Step 5 To turn the heater OFF Press the **ON/OFF** button on the touchpad.

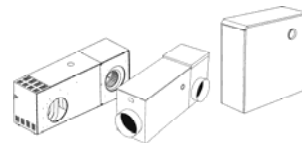

Ducted Gas Central Heating

The Touch Pad remembers your SET TEMPERATURE setting and uses it next time you turn it ON.

As your activities vary, you may find you need different temperature settings, e.g. a temperature comfortable for sitting is usually too warm compared to when you're moving about.

For economical operation, set a lower set temperature during the day when you are active, or use economy (ECON). Switch the Touch Pad OFF when asleep and ON again when awake. These cost saving functions can be programmed to operate automatically (see Programmed Control).

ECONOMY & BOOST FOR HEATING

Economy (ECON) operates the heater at the lowest fan speed and a lowest possible gas rate. This is best used once the space has been brought up to temperature.

BOOST operates the heater at the highest fan speed and a highest possible gas rate.

The unit will switch off when the SET TEMPERATURE is reached.

Step 1 To select economy or boost switch the Controller ON.

Step 2 Ensure the APPLIANCE outline is set to HEAT.

Step 3 Press any where in the MODE outline to see the available icons.

Step 4 Press the ECON or BOOST icon so that it stops flashing. The remaining icons will flash 5 more times and disappear.

Step 5 Use the   arrows to adjust the SET temperature as required.

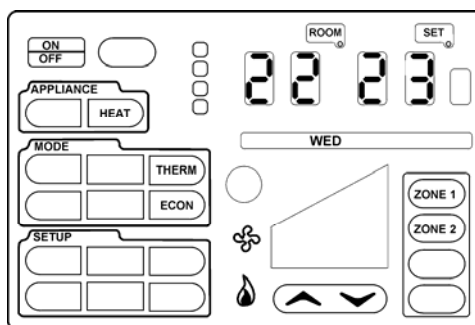

FAN

The fan in your heater can be used to circulate the room air without running the heater. To run the fan only option:

Step 1 To select FAN only switch the Controller ON

Step 2 Ensure the APPLIANCE outline is set to HEAT.

Step 3 Press any where in the MODE outline to see the available icons.

Step 4 Press the FAN icon so that it stops flashing. The remaining icons will flash 5 more times and disappear. The room air fan will now run.

Step 5 Use the   arrows to adjust the fan speed as required.

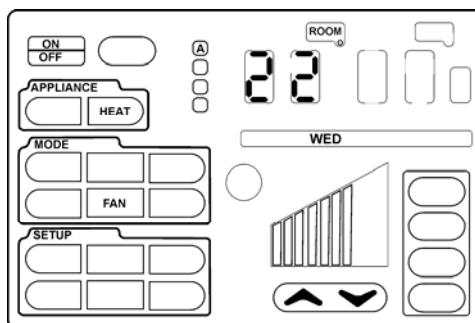

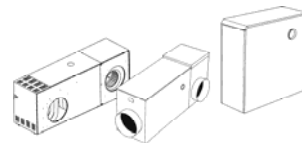

Ducted Gas Central Heating

ZONES

Selecting ZONE 1 2 3 4 only applies if your home is fitted with optional motorised ductwork dampers (please consult your installer) that allow opening or closing of each section of ducting.

Many homes have no motorised ductwork dampers fitted, however the control will still display the zones. Where zone motors are fitted the installer can set your controller to show only the zones available for use.

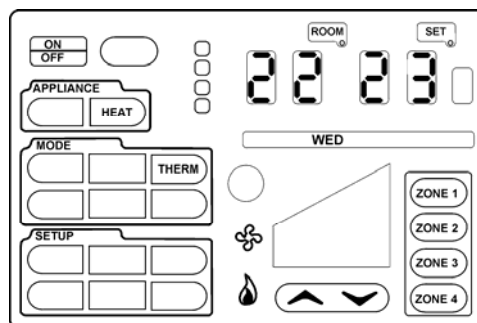

In homes with more than one zone, the default requires at least one zone open at all times. The common zone feature, which allows all zones to be turned off, can only be applied to specific duct designs. This must ONLY be set by the installer.

SETTING THE OPEN OR CLOSED STATUS

- Step 1** To select ZONES switch the Touch Pad Control ON.
- Step 2** Ensure the Appliance is set to HEAT and THERM.
- Step 3** Press any where in the ZONE area to see the available zone icons.
- Step 4** To turn a ZONE ON, press the **ZONE** icon required to make it solid.
To turn a ZONE OFF press the **ZONE** icon to make it flash.

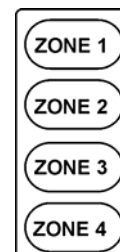

The flashing icons will flash 5 more times and disappear. In approximately 30 seconds the new zone settings will be effective.

PROGRAMMING YOUR TOUCH PAD

Programming your Touch Pad will provide energy and operating time savings. Your heating and or cooling system will only operate when you need it, and at your chosen comfort levels.

Determine your most comfortable settings, program them and let your Touch Pad do the rest automatically.

Turning on the program function

Press the PRGM button in the mode panel to run program.

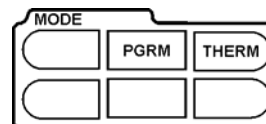

Programming Sequence

If you've never programmed your Touch Pad control before (or it's been a while) remember it's easier to program the whole week to the same settings (by selecting the whole week MON TUE WED THU FRI SAT SUN day choice) and then program variations for particular days or the weekend as you become more familiar with programming.

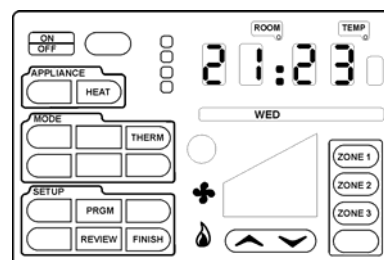

If the Controller exits program mode it may be because you've paused longer than about 60 seconds to make your next choice. All the settings you've made up to then in a completed program period (Period 1, 2, or 3) will be saved. Just switch back to PRGM in setup, select the day combination and scroll through your settings using the ENTER key and carry on from where you left off.

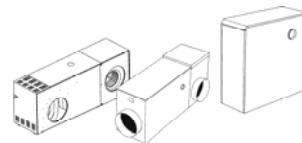

Ducted Gas Central Heating

During the program sequence only the icons requiring changing for each step will be displayed.

In the SETUP outline, there are 2 setup mode icons PGRM and CLOCK as well as 4 function icons, ENTER, CANCEL, REVIEW and FINISH. To enter setup mode, touch anywhere within the SETUP outline. The accessible icons will be displayed.

Program Setup

Program setup will take you through the steps to set your Ducted Gas Central Heater up for automatic control:

Step 1 To select the PGRM (Program) mode touch anywhere in the SETUP outline.

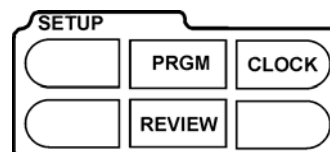

Step 2 Press PGRM. The 3 icons will disappear and edit mode has begun with the 1st period.

Two new icons will now be displayed ENTER & CANCEL.

- ENTER will save each step of the program
- CANCEL will step back the program 1 step at a time.

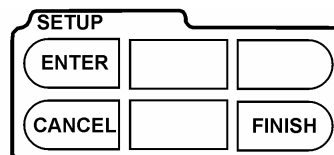

Step 3 Using the arrows select the day or day grouping to program. Press ENTER

Step 4 Period 1 will be displayed with ON or OFF. Using the arrows make a selection if required and press ENTER.

Step 5 Set the Hour using the arrows and press ENTER

Step 6 Set the Minutes using the arrows and Press ENTER

Step 7 Change the Unit in the APPLIANCE area if required.

Step 8 Select the MODE of operation, THERM, ECON, BOOST, FAN (only) and press ENTER.

Step 9 If zones are fitted, select the zones required to be open.

Step 10 Adjust the SET temperature using the arrow. Press ENTER

The First Program period is now completed.

Default Setup Ducted Gas Central Heating Program

Step 11 Program the second period using steps 4 to 9

Step 12 If only 2 program periods are required press FINISH. If a 3rd period is required program using steps 4 to 9.

Step 13 If only 3 program periods are required press FINISH. If a 4th period is required program using steps 4 to 9 and press FINISH.

| Event | ON/OFF | Start Time | Mode |
|-------|--------|------------|-------|
| 1 | ON | 6:00 am | THERM |
| 2 | OFF | 9:00 am | - |
| 3 | ON | 4:00 pm | THERM |
| 4 | OFF | 10:00 pm | - |

IMPORTANT NOTE: The program does not automatically start at this point.

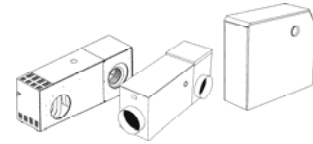

Ducted Gas Central Heating

To start the program, touch the MODE outline area for the available icons to be displayed. Press PRGM icon and make solid. The icons will flash 5 more times and program mode will be engaged.

Reviewing Entered Programs

REVIEW is a feature that allows you to first view the current program settings. Each step remains visible for 3 seconds.

Once the review procedure has started the FINISH icon will be illuminated. The FINISH icon can be used to stop the REVIEW process.

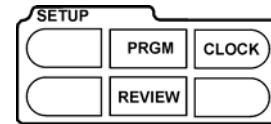

USING THE PROGRAM MODE (PGRM)

Activates the 4 program x 7 day / night timer.

To operate the PGRM mode:

Step 1 Turn the Touch Pad on, press and release the ON/OFF button. If there is only a central heater HEAT will automatically display in the Appliance area.

Step 2 Press the **MODE** outline. The available icons will flash. Select **PGRM**.

The icon will become solid and the remaining icons will flash 5 more times before disappearing.

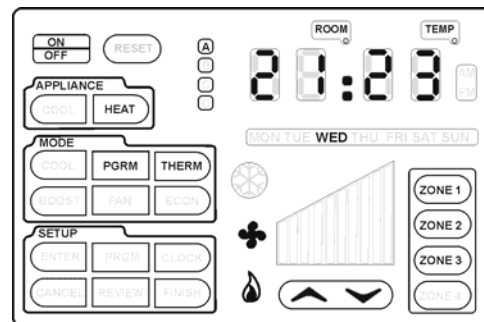

The touchpad will now be in program mode with the current program settings being indicated e.g. time period, mode of operation, period and settings.

Step 3 To exit the PGRM mode you have 2 options.

1. Turn the unit off using the ON OFF button
2. Press the **MODE** area. The available icons will flash. Select a new mode of operation.

PROGRAM OVERRIDE (PGRM)

When PGRM is selected, the program can be overridden within an event period (1, 2, 3, or 4) without altering the program setup. There are 2 scenarios for changing the event:

1. When the program event is ON, operating the unit:

The operating parameters can be altered temporarily. Simply adjust the temperature or change the zone selection (where fitted) at any time.

2. When the program event has the unit turned OFF.

To override the PGRM mode when the unit is scheduled to be OFF, press and hold the PGRM mode button for 5 seconds until it beeps and then immediately select one of the mode functions available. The PGRM button will remain illuminated with your new selection.

The event number will now flash, indicating a temporary change to the program. The program will reset itself once the next timed event has started or if the PRGM in the mode section is turned OFF then ON or if the touchpad has been turned OFF then ON.

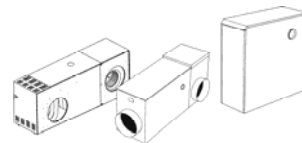

Ducted Gas Central Heating

CLOCK SETUP

Timer setup will take you through the steps to set your 12-hour clock. You can use FINISH at any stage of setting the Day and Time.

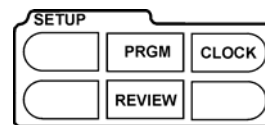



Step 1 To select the CLOCK setup touch anywhere in the SETUP outline.



Step 2 Press CLOCK. The 3 icons will disappear and edit mode has begun.

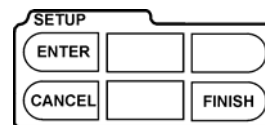

Step 3 Three new icons will now be displayed ENTER, CANCEL & FINISH.

- ENTER will save each step of the program
- CANCEL will abort the setup and no entries will be saved.
- FINISH allows you to stop at any time and save the settings.



Step 4 Adjust the hours using the   arrows. Press ENTER

Step 5 Adjust the minutes using the   arrows. Press ENTER.

Step 6 Adjust the day using the   arrows. Press ENTER

Time setup is now complete and all functions are resumed.

SUMMER SHUTDOWN (OPTIONAL)

Step 1 Switch the Touch Pad OFF



Step 2 Switch the power point OFF and turn the gas tap OFF. These connections are usually located close to the Heater.

FIRST STARTUP OR RESTART AFTER SHUTDOWN

Step 1 Switch on the power point to the heater. Turn on the gas tap on the gas supply line into the heater.

Step 2 Switch the Touch Pad ON.

Step 3 Select HEAT in the Appliance area if not already displayed.

Step 4 Press the   arrows to increase or decrease the SET TEMPERATURE. If the set temperature is greater than the room temperature, the heater will resume operation.

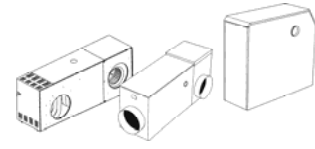

Ducted Gas Central Heating

Ducted Gas Heating Maintenance

GENERAL MAINTENANCE

Return Air Grille Filter.

If your heating system has a filter in the return air grille, it is extremely important it is cleaned every 3 – 4 weeks during the operating period to ensure correct operation of the heating unit. Failure to do so may cause your heater to stop because of over temperature and cause an unnecessary service call not covered by warranty.

Electrical

Warning: Before commencing any maintenance work on your unit, isolate the power at the supply (Fuse Box).

No general maintenance is required to the electrical system.

A Licensed Electrician only should carry out electrical connections and maintenance.

Flue

The flue and cowl assembly should be clean and free of obstructions.

SCHEDULED MAINTENANCE

Note: It is essential that your central heater be maintained in accordance with Climate Technologies requirements. Failure to do so will affect the life of the product and reduce the level of efficiency which may also affect your warranty.

Your Ducted Gas Central Heater should be serviced at least every 2 years to ensure trouble free operation.

1. To ensure that your heater continues to operate at peak efficiency it is recommended that it be periodically serviced by a qualified service technician (for your nearest Climate Technologies service office refer to Service section of this document).
2. Fan blades, motors, ignition systems and burners should be checked. Heater cabinet and immediate surroundings should be kept clean and clear.

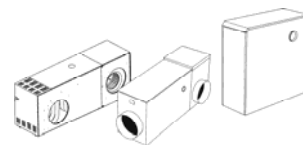

Ducted Gas Central Heating

Problem Solving

Central Heater will not operate!

| Question | | Y/N | Solution |
|----------|---|-----|---|
| 1. | Has the unit been run since installation? | Yes | Refer to question 4 |
| | | No | Check the unit is turned on at the power point and the gas cock is turned on. Call the installer to commission the unit. |
| 2. | Is the unit installed in a new home? | Yes | Refer to question 3 |
| | | No | Refer to question 4 |
| 3. | Has the installer run the unit? | Yes | Refer to question 4 |
| | | No | Check the unit is turned on at the power point and the gas cock is turned on. Call the installer to commission the unit. |
| 4. | Is the SET temperature greater than the room temperature? | Yes | Press the reset icon or turn the unit off then on to reset unit. If the unit still does not start call for service. (refer to solution 6 for reset instructions) |
| | | No | Increase the SET temperature so the thermostat calls for heat. |
| 5. | Is the thermostat in program mode? | Yes | The heater may be programmed to be OFF. To override the program press anywhere in the MODE outline and selecting the required icon. The program will resume at the program period start time. |
| | | No | Adjust the room thermostat greater than SET temperature. |
| 6. | Has there been a known power surge? | Yes | Reset the heater. This can be done by: Pressing and holding the RESET icon until a BEEP is heard. The unit should resume operation. |
| | | No | Unit should operate normally. If not a service call will be required. |

THIS TROUBLE SHOOTING GUIDE IS A REFERENCE ONLY.

FOR SERVICE OR WARRANTY REQUIREMENTS PLEASE REFER TO
THE WARRANTY SECTION OF THIS BOOK

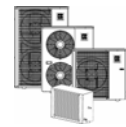

Dual Cycle – Refrigerated Air Conditioning

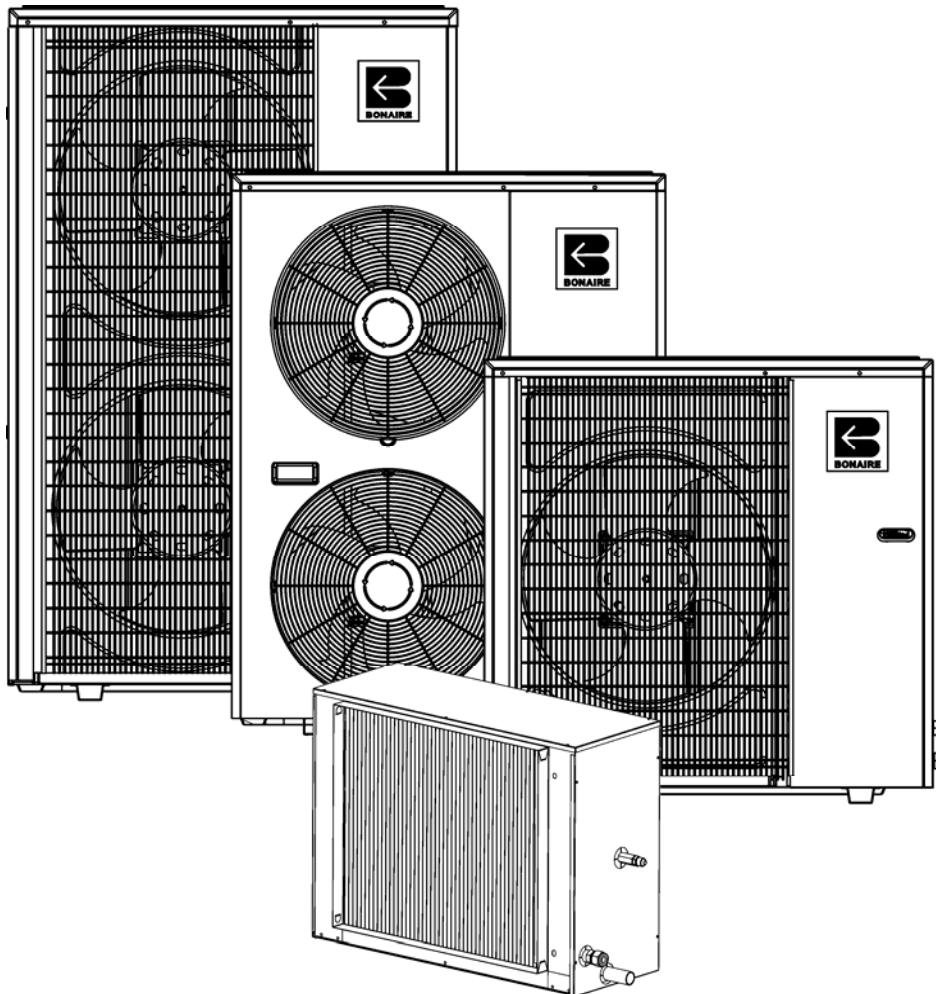

Owners Operating and Maintenance Details

Please keep this important manual in a safe place. It is the owner's responsibility to ensure that regular maintenance is carried out on this Ducted Gas Central Heater / Dual Cycle Air Conditioner. Failure to do so will void all guarantees beyond statutory and legal requirements.

www.climatetechnologies.com.au

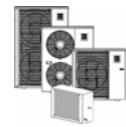

Dual Cycle – Refrigerated Air Conditioning

General Information.

IMPORTANT NOTICE

A licensed person is required to install Climate Technologies equipment. If the equipment is not installed in accordance with the installation instructions and the governing body regulations, Climate Technologies reserves the right to refuse service on non compliant installations.

Subject to state regulations and by laws a certificate of compliance must be issued for the electrical and plumbing connections certifying that the work complies with all the relevant standards.

Note: Only a licensed person will have insurance protecting their workmanship.

DATA LOCATION

Your appliance model number, serial number and model description are located on the appliance data plate on the end of the ducted gas heater / Dual Cycle air conditioner in the vicinity of the electronic controls access. These details should also be in the warranty section of this booklet.

You will need this information, should your appliance require servicing, spare parts or just if you require additional information about this product.

ASSEMBLY

There is no assembly required of this Dual Cycle Refrigerated Air Conditioner. Your Dealer or installer will carry out all assembly and commissioning upon installation.

Safety

SAFETY & OWNER RESPONSIBILITY

The manufacturer and its service providers reserve the right to refuse service unless safety and accessibility to the unit can be guaranteed. The cost of any extra equipment required to provide access to the unit for servicing is the responsibility of the owner.

PRECAUTIONS

DO NOT PLACE ARTICLES ON OR AGAINST THE CONDENSER.

DO NOT PLACE ARTICLES IN FRONT OF THE CONDENSER.

ENSURE THE CLEARANCES BETWEEN THE UNIT AND WALL ARE KEPT CLEAR.

DO NOT PLACE ARTICLES IN FRONT OF OR OVER THE RETURN AIR GRILLE.

FEATURES

Your Ducted Gas Central Heater and Dual Cycle Refrigerated air conditioner has all the safety devices to ensure safe operation. These devices conform to the standards set out by the Standards Australia.

POWER INTERRUPTION

Should there be an interruption to the power supply during the heating / cooling operation the controls will automatically shut the unit down.

Your gas ducted heater and or Dual Cycle cooler will be ready to resume operation once the power has been restored.

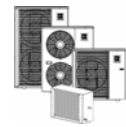

Dual Cycle – Refrigerated Air Conditioning

Using Your Touch Pad with Dual Cycle Air Conditioning

Using your Touch Pad for manual operation of your Dual Cycle Refrigerated Air Conditioner is the same as your gas central heater where you want direct control, without timers or programming.

MANUAL OPERATION

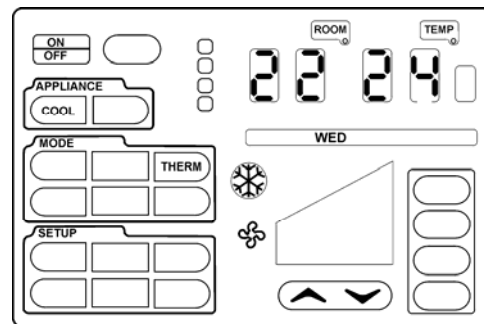

Step 1 Turn the Touch Pad on, press and release the **ON/OFF** button. **HEAT** or **COOL** may be displayed in the **APPLIANCE** area. Select **COOL** if not already displayed.

NOTE: Your Touch Pad Control is designed to automatically detect the appliances you have installed. Controller options not required for your appliances will not be visible on your Touch Pad Control display. So don't worry if you don't see all the menu items listed in this book.

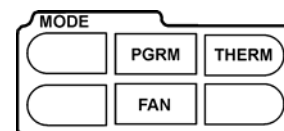

Step 2 Press anywhere in the **MODE** outline. The available icons will flash. Select **THERM**. The icon will become solid and the remaining icons will flash 5 more times before disappearing.



Step 3 Press the   arrows to decrease or increase the set temperature (**TEMP**).



Step 4 Touch Pad measures the room temperature using a thermostat inside its case. When the room temperature is colder than the set temperature (**TEMP**) the Dual Cycle Cooler will Turn OFF. The cool symbol and fan symbol will be displayed on the control to indicate the Dual Cycle Cooler is on.

For continuous fan, meaning the fan runs continuously and the condenser unit only cycles ON and OFF the display should show **FAN** and **THERM**.

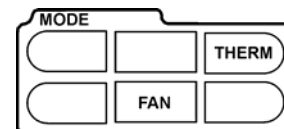

Step 5 The Touch Pad will run the Dual Cycle Cooler until it measures the room temperature (**ROOM**) a little below your set temperature (**TEMP**) and then turn off the condenser unit until the temperature rises a little below **SET** temperature.

The operation of the Dual Cycle Cooler is as follows:

- The Dual Cycle cooler will start almost immediately when first turned ON. Once the unit has turned OFF when in operation there is a 5 minute delay before it will resume again and a minimum of 5 minutes operating time before it can turn off again.
- The room air fan will always run on high speed. The room air fan can be set as always on or it can be set to cycle ON and OFF with the Condenser Unit.
- When the temperature has gone under the **SET** temperature by approximately 1° the condenser unit will shut down.
- When the temperature has gone over the **SET** temperature by approximately 1° the Dual Cycle cooler condenser unit will restart.

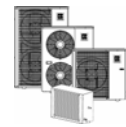

Dual Cycle – Refrigerated Air Conditioning

- As your activities vary, you may find you need different temperature settings, e.g. a temperature comfortable for sitting is usually too cool compared to when you're moving about.

Step 6 Press the **ON/OFF** button to switch the Dual Cycle Cooler OFF.

Step 7 The Touch Pad remembers your SET TEMPERATURE setting and uses it next time you turn it ON.

ZONES - SELECTING ZONE 1, 2, 3, OR 4

Selecting ZONE 1, 2, 3, 4 applies with Dual Cycle air conditioning because the suitable cooling unit will normally achieve effective cooling in a smaller portion of your home than compared to the gas heating.

The installer will have set your controller to show the zones you have available.

In homes with more than one zone, at least one zone must be open at all times.

To set the open or closed status of a ZONE:

Refer to ZONES - Selecting ZONE 1, 2, 3 or 4 options in the Ducted Gas Central Heating Section.

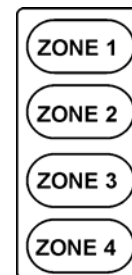

PROGRAMMING YOUR TOUCH PAD

Programming your Touch Pad will provide energy and time savings. Your heating/cooling system will only operate when you need it, and at your chosen comfort levels.

Determine your most comfortable settings, program them and let your Touch Pad Control do the rest automatically.

PROGRAMMING SEQUENCE

Refer to Programming Sequence in the Ducted Gas Central Heating Section.

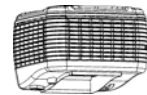

Ducted Evaporative Air Conditioning

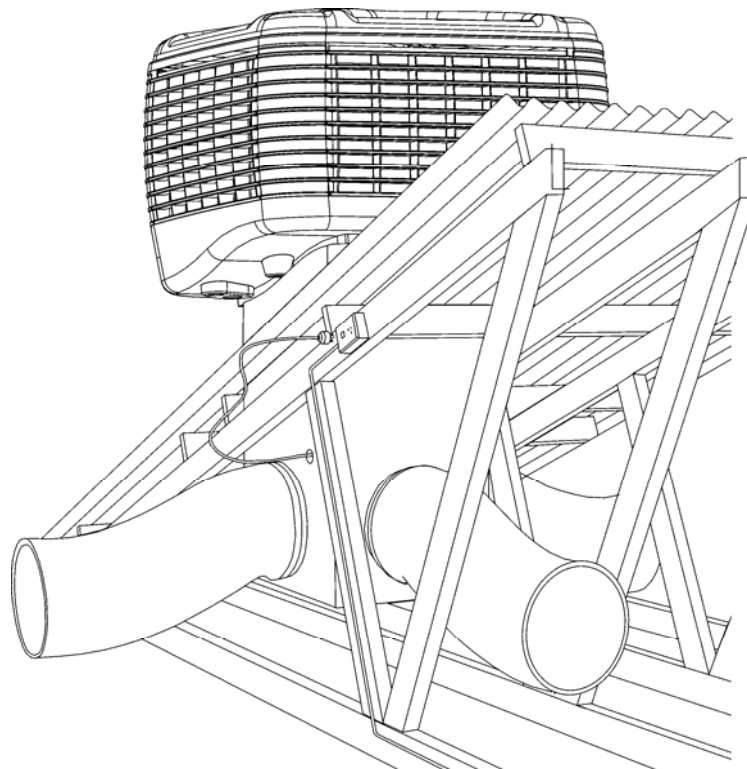

Owners Operating and Maintenance Details

Please keep this important manual in a safe place. It is the owner's responsibility to ensure that regular maintenance is carried out on this Evaporative Air Conditioner. Failure to do so will void all guarantees beyond statutory and legal requirements.

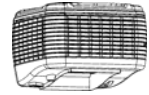

Ducted Evaporative Air Conditioning

Introduction

Your ducted evaporative air conditioner is engineered to meet the rigours of our harsh Australian environment. Operated and maintained in accordance with this manual, it will provide you with years of cool and environmentally friendly operation. Please take the time to read this manual.

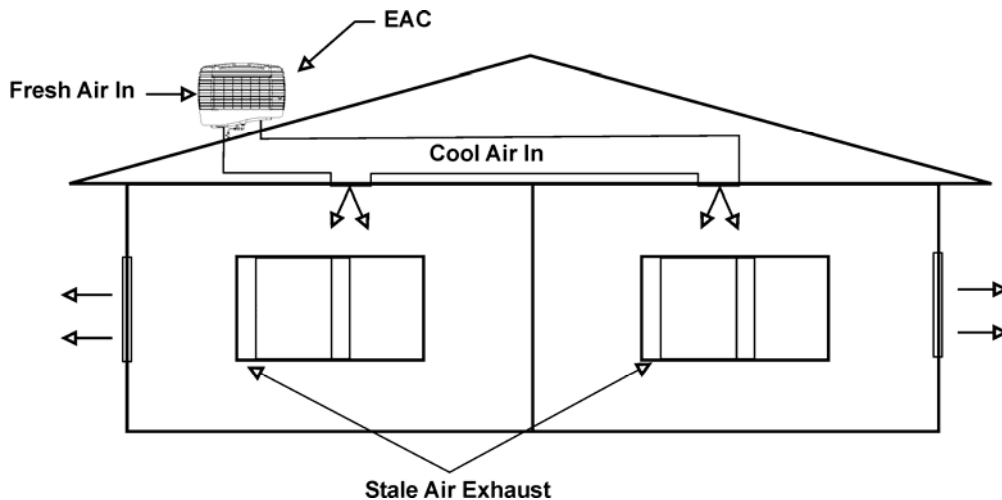

The principal of your unit is to introduce fresh air, which is washed through the filter pads to provided cool fresh air. The air is exhausted taking with it any heat loading on the home.

EXHAUST

It is essential for successful operation of evaporative air-conditioning that there are sufficient exhaust openings in the area to be ventilated. Open doors and windows will usually provide this.

The minimum exhaust opening should be as per the table guide set out below. It is recommended that ceiling vents or exhaust fans be used where there is any doubt about there being sufficient exhaust area available. Ceiling exhaust fans or ceiling vents should have a capacity equivalent to that of the air conditioner.

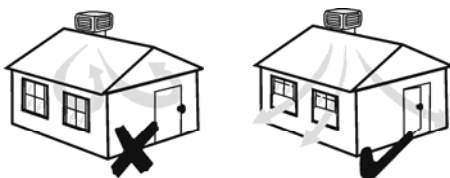

Vent Area for Doors and Windows

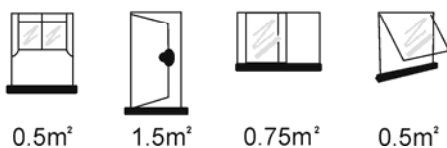

| MODEL | MINIMUM EXHAUST AREA |
|--------|--|
| Small | 0.85 m ² |
| Medium | 1.19 m ² to 1.48 m ² |
| Large | 2.02 m ² |

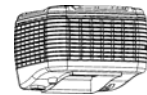

Ducted Evaporative Air Conditioning

WATER MANAGEMENT

All evaporative air conditioners need some water to go to waste to prevent build-up of mineral deposits in the system. Your unit has been supplied with a dump valve as well as a bleed control to provide maximum options for best water management.

The correct setting of the dump valve and bleed will ultimately govern the life of the unit. Should there be evidence of a build up of mineral deposits in the unit, review the dump and or bleed-off values.

Failure to manage the correct levels of dissolved solids in the unit will void warranty. Refer to your local dealer for best settings.

Dump Valve

The dump valve provided with your unit is able to be operated with various timed dumping options (0, 1, 2, 4, 8, 12, 24 hours).

Dumping cycles will have to be activated (refer to the setup section of this document) and set in accordance with the water quality in your area. In areas of good water quality, the correct dumping cycle only may suffice and the bleed-off function in the Dialflo may not be required. Increased water hardness may require a bleed rate as well as a dump cycle and increased maintenance.

Drainage from the dump valve must be plumbed away in accordance with local and state plumbing requirements. However this water could also be stored in a non drinking water tank for other use.

Set the Water Distribution Flow Rate

To set the water distribution rate locate the DIALFLO externally on one of the unit corner posts. Rotate the filter knob (the outer knob) anti-clockwise for more water and clockwise for less water. Do this before setting a bleed rate.

Set the BLEED-OFF Rate.

Use the DIALFLO to rotate the BLEED knob (the inner knob) clockwise for more water flow and anti clockwise for less.

Note: Hold the distribution knob (Filters) while setting the bleed rate as the distribution flow rate may go out of adjustment.

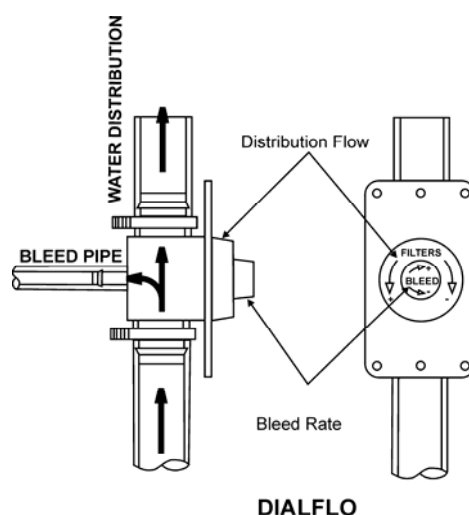
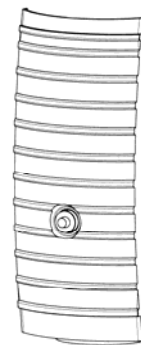
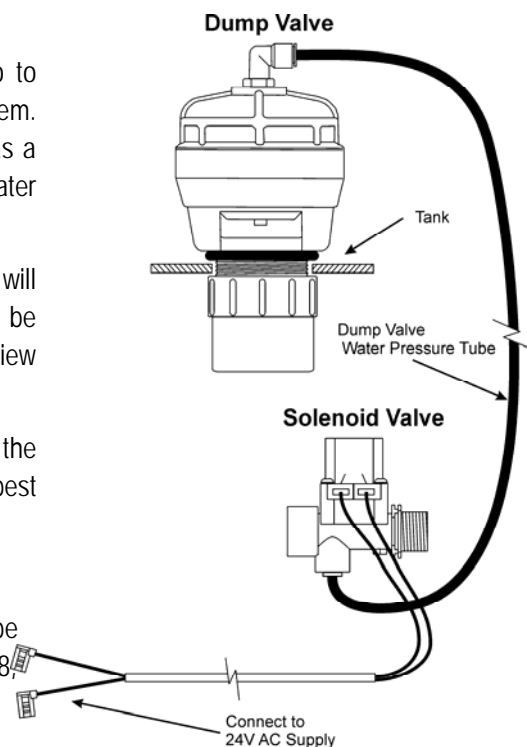

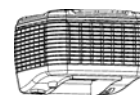



Ducted Evaporative Air Conditioning

Operating the Touch Pad

To operate your touch pad control simply press the operating area required firmly until a "BEEP" is heard. The unit will then display the next available options or it will be ready to operate.

If the unit has been setup to use "Pre-cool" the fan and cool icons will flash for approximately 3 minutes while the filters are saturating before the room fan delivers cool fresh air.

COOL MODE

- Step 1** Press the ON / OFF button to turn the unit on.
- Step 2** Check the Appliance is selected as COOL.
- Step 3** To select the COOL (Fan and Pump) or FAN mode touch anywhere in the MODE outline and the available icons will be illuminated.
- Step 4** Press COOL or FAN. The selected icon will stop flashing. The remaining icons will flash 5 more times and then disappear.
- Step 5** To adjust the air output use the   to adjust the air output. The level of adjustment is measured by the bar graph display.

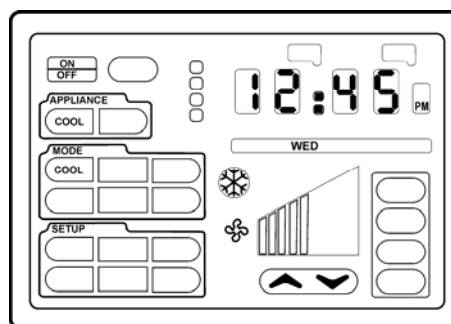

BOOST MODE

Boost mode is an option to run the unit in cool mode at maximum speed. If the unit is in COOL mode prior to pressing BOOST the unit will operate in cool BOOST. If the unit is in FAN mode prior to pressing BOOST, the pump will not operate.

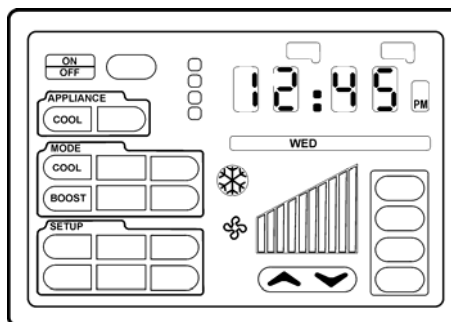

- Step 1** To select the BOOST touch anywhere in the MODE outline and the available icons will flash.
- Step 2** Press BOOST to select the MODE and the icon will stop flashing. The remaining icons will flash 5 more times and then disappear.

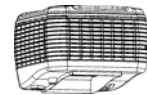



Ducted Evaporative Air Conditioning

THERMOSTAT MODE

- Step 1** Press the ON / OFF button to turn the unit on.
- Step 2** Check the Appliance is selected as COOL.
- Step 3** To select the THERM (Thermostat) mode touch anywhere in the MODE outline.
- Step 4** Press THERM and the selected icon will stop flashing. The remaining icons will flash 5 more times and then disappear.
- Step 5** To adjust the comfort level use the   arrows. Increase the graphics scale for more cooling, decrease for less cooling.

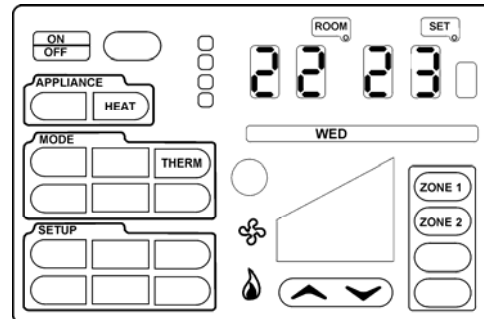

Note: The comfort level is individual to each situation and location. Some trial and error may be required to set the graphic scale to your desired comfort level; a good starting point is to have the scale set at approximately the half way mark. Once the unit has been set, the fan speed and pump are controlled automatically. The unit can be left and will cycle on and off to keep the area being cooled to the set comfort level.

PROGRAM MODE

- Step 1** Press the ON / OFF button to turn the unit on.
- Step 2** Check the Appliance is selected as COOL.
- Step 3** To Select the PRGM (Program) mode touch anywhere within the MODE outline.
- Step 4** Press PGRM. The selected icon will stop flashing and the remaining icons will flash 5 more times and then disappear. In addition the programmed mode of operation icon will be displayed when the program calls for it as well as the period (1, 2, 3, or 4).

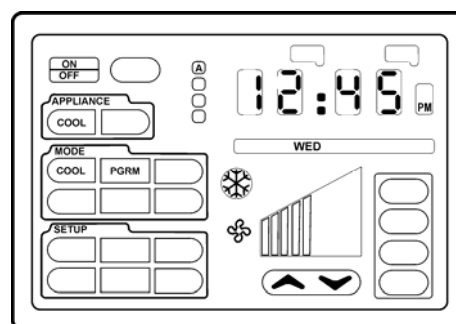

This function will only enable program mode. To setup the program parameters refer to the section "Operating the Touch Pad – SETUP" to edit the settings.

Program Mode will only operate for a 24-hour period from activation and then the product will cease to function until the unit is restarted or program is reactivated.

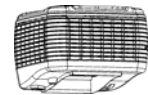

Ducted Evaporative Air Conditioning

Setup

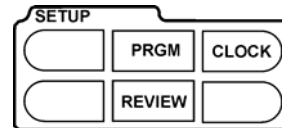
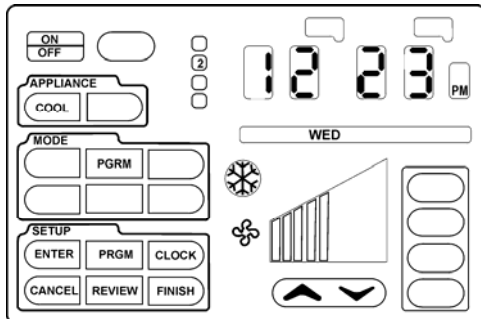

Accessible Icons

In the SETUP outline, there are 2 setup mode icons and 4 function icons. To enter setup mode, touch anywhere within the SETUP outline. The accessible icons will be displayed.

Review

Review is a feature that allows you to first view the current program settings. Each step remains visible for 3 seconds.

Once the review procedure has started the FINISH icon will be illuminated. The FINISH icon can be used to stop the REVIEW process.

PROGRAM SETUP

The PRGM setup will take you through the steps to set / edit activities for your evaporative air conditioner. These will only be activated once the PGRM icon is made solid in the mode area.

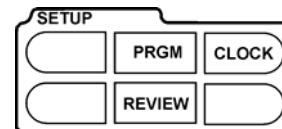



Step 1 To select the PGRM (Program) mode touch anywhere in the SETUP outline.

Step 2 Press PGRM. The 3 icons will disappear and edit mode has begun with the 1st period.

Step 3 Two new icons will now be displayed ENTER & CANCEL.

- ENTER will save each step of the program
- CANCEL will step back the program 1 step at a time.

Step 4 The first period will be displayed with ON or OFF. Using   the arrows make a selection and press ENTER.

Step 5 Set the Hour using the UP DOWN arrows and press ENTER

Step 6 Set the Minutes using the   arrows and Press ENTER

Step 7 Select the MODE of operation and press ENTER.

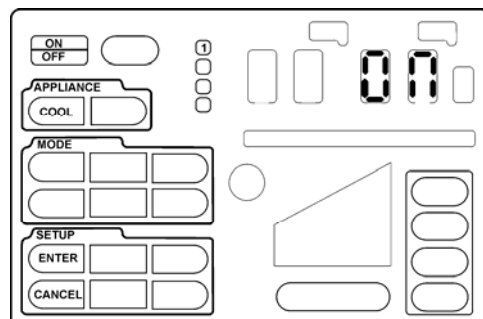

Continued next page.

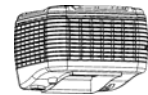

Ducted Evaporative Air Conditioning

Step 8 Adjust the output using the arrows and press ENTER

Step 9 Program the second period using steps 4 to 8.

Step 10 If only 2 program periods are required press FINISH. If a 3rd period is required program using Steps 4 to 8.

Step 11 If Only 3 Program Periods Are Required press FINISH. If a 4th period is required program using Steps 4 to 8.

Program setup is now complete and all functions are resumed.

Step 12 To execute the program, touch the mode area and select PRGM.

Default Setup Evaporative Air Conditioning Program

| Period | ON/OFF | Start Time | Mode |
|--------|--------|------------|-------|
| 1 | ON | 6:00 am | THERM |
| 2 | OFF | 9:00 am | - |
| 3 | ON | 4:00 pm | THERM |
| 4 | OFF | 10:00 pm | - |

CLOCK SETUP



The CLOCK setup will take you through the steps to set the day and time.

Step 1 To select the CLOCK setup touch anywhere in the SETUP outline.

Step 2 Press CLOCK. The 3 icons will disappear and edit mode has begun.

Step 3 Three new icons will now be displayed ENTER, CANCEL & FINISH.

- ENTER will save each step of the program
- CANCEL will abort the setup and no entries will be saved.
- FINISH allows you to stop at any time and save the settings.

Step 4 Adjust the hours using the   arrows. Press ENTER

Step 5 Adjust the minutes using the   arrows. Press ENTER.

Step 6 Adjust the day using the   arrows. Press ENTER.

Time setup is now complete and all functions are resumed.

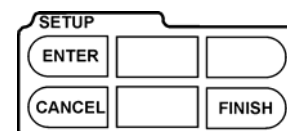
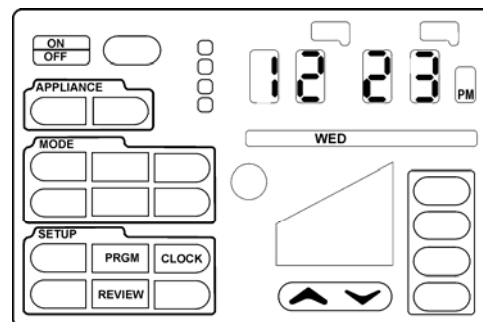

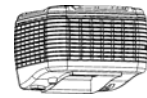

Ducted Evaporative Air Conditioning

Ducted Evaporative Air Conditioner Maintenance

GENERAL.

All Ducted Evaporative Air Conditioners benefit from some general maintenance to ensure continued cooling efficiency and a long life. Maintenance is carried out at the beginning and end of summer to start up and close down your unit.

We recommend that all maintenance work be undertaken by our fully trained and accredited Service Technicians or an authorised Climate Technologies Service Provider.

The frequency of general maintenance will depend on local operating conditions such as water quality, air borne dust and pollen.

It is essential that your evaporative air conditioner is maintained in accordance with this manual. Failure to do so will affect the life of the product, reduce the level of efficiency and may void warranty.

For service Australia wide refer to the details on the service section of this manual.

NOTE: The manufacturer and its agents reserve the right to refuse service unless safety and accessibility to the unit can be guaranteed. The cost of any extra equipment required to provide access to the unit for servicing is the responsibility of the owner.

SAFETY: Prior to commencing any maintenance isolate the unit at the power source. Ensure the roof is safe to access, your ladder is securely positioned and use suitable safety equipment.

FILTER PADS

Visually check CELDEK pads for damage or blockage. Hose down pads from both sides to remove any build up of salts, dust and pollen. In dusty areas more regular cleaning is recommended. Check the water distributor, making sure it is clear and free from blockage. Failure to do so may lead to uneven water distribution and therefore less efficient operation.

WATER TANK

It is important to keep the water tank clean and free from sediment and algae growth. To clean the tank, use a soft brush or similar. Wipe all surfaces in the tank while it is full of water (DO NOT FORGET THE PUMP STRAINER). Turn off the water inlet to the unit (an Isolation Valve should be fitted to the water inlet before the Float Valve). Drain the tank by removing the 40mm overflow pipe. It may be necessary to repeat this procedure if the tank is very dirty.

SAFETY: Wet roofs are dangerous – Take Care When Draining Tank.

WATER LEVEL / FLOAT VALVE

The water level should be set at nominal 65-70mm from the top of the overflow before filter pads are saturated. After run off from operating filters the level from the top of the overflow fitting should be 25 – 30mm. The float valve is a mechanical type and is factory set. If it requires adjustment keep bends tight. If the valve is leaking the seal may require cleaning or replacing. Turn off the water. Remove the split pin and then float arm. Remove piston and clean or turn seal. Flush system and replace piston, float arm and split pin.

Note: Water supply line to float valve must be flushed before connecting.

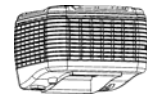

Ducted Evaporative Air Conditioning

Note: Some discharge from the overflow may be experienced after shut down due to water draining back from the Celdek pads. This is normal.

MOTOR AND FAN

Check that the fan spins freely and that there is no build up on the blades.

ELECTRICAL

No general maintenance is required to the electrical system.

A Qualified Electrician should only carry out electrical connections and maintenance.

BLEED OFF

The bleed rate should be checked to ensure it is adequate and that there is no build up of mineral deposits in or on your air conditioner. White deposits indicate high mineral content and the Bleed Rate should be increased. If it is at maximum and the deposits are still forming, then more regular maintenance is required.

PUMP

Check the pump spins freely and that the strainer is clean.

WATER DISTRIBUTION

Check the water distribution system for blockage. Check the delivery tube for kinks or holes. Check that the clamps are secure and in place.

NO SEASONAL MAINTENANCE

Your unit has been supplied with a dump valve system. As long as the dump valve has been fitted, there is no need for regular checking of the system during the operating (summer) period. This however does not remove the responsibility of the customer to have the unit service on an annual basis to check the unit function and to ensure the unit is clean and free from any mineral deposit build up.

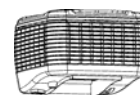

Ducted Evaporative Air Conditioning

Trouble Shooting Guide

| PROBLEM | PROBABLE CAUSE | REMEDY |
|---|--|--|
| Unit fails to start | <ul style="list-style-type: none"> A Black – out b Tripped Circuit Breaker c Blown Fuse d Electrical Fault | <ul style="list-style-type: none"> a Wait b Reset c Replace d Call Climate Technologies Service Provider |
| Pump fails to start | <ul style="list-style-type: none"> a Pump Seized b Pump Burnt Out | <ul style="list-style-type: none"> a Isolate power and then take off top of pump and try to free it. Some lubricant may help. b Call Climate Technologies Service Provider |
| Water leaking from overflow | <ul style="list-style-type: none"> a Float Valve Leaking b Drain from Celdek Pads | <ul style="list-style-type: none"> a Check adjustment or replace seal b Normal Operation |
| Water Droplets in air stream | <ul style="list-style-type: none"> a Loose Delivery Tube b Break in tubing c Pump Delivers Excessive Water to Pads | <ul style="list-style-type: none"> a Check and tighten b Replace as necessary c Adjust the Dialflo to reduce the flow |
| Excessive humidity | <ul style="list-style-type: none"> a Inadequate Exhaust b Outside humidity high | <ul style="list-style-type: none"> a Provide more open area to exhaust stale air b Turn pump off. |
| Inadequate Cooling | <ul style="list-style-type: none"> a Dirty Filters b Dry Filters c Dialflo not set correctly | <ul style="list-style-type: none"> a Clean / Replace b Check water delivery system. Adjust if necessary. c Adjust Dialflo so that the pads have even saturation. |
| Unpleasant Odor | <ul style="list-style-type: none"> a Unit located near odor source b New Celdek filter smell | <ul style="list-style-type: none"> a Remove source b Smell will disappear after a period of operation (Approximately 48 hours or use). |
| Rapid formation of white deposits on pads | High Mineral Content | Bleed off should be set at maximum. More regular maintenance may be required. |

THIS TROUBLE SHOOTING GUIDE IS A REFERENCE ONLY.

FOR SERVICE OR WARRANTY REQUIREMENTS PLEASE REFER
TO THE WARRANTY SECTION.



Controls – Installation / Setup / Commissioning

Setting Up the Control - General

BEFORE STARTING

Before attempting to use the setup instructions for the controls system, make sure the low voltage cable is connected and the 240 volt power has been turned on to the heater / cooler.

The Low voltage controls are connected to the unit control box / controller via a 20-metre low voltage loom.

NOTE: Do not run the low voltage loom in long parallel runs with 240V mains cables. Keep the low voltage loom 200mm away from any long runs of mains wiring.

Cross over mains wiring at right angles.

Do not use existing access holes in wall cavities where 240V mains wiring exists. Drill a new access hole 200mm from the existing hole.

INSTALLATION

Where the control is using the thermostat for operation, it must be installed approximately 1.5 metres above the floor level on a room wall which is most commonly used for best average sensing.

Secure the Touch Pad Control back panel to the wall using screws and plugs.



Do not locate Touch Pad near concealed hot or cold water pipes, warm air ducts, radiators, sunlight, or draughts from hallways, stairways or fireplaces and seal against draughts through wall cavities. These can all affect the temperature.



Controls – Installation / Setup / Commissioning

Using the Setup Modes

There are a series of available parameters that can assist the installer to set the unit up to specification and tailor the control to meet the customer's requirements. Carefully read these tables before entering the maintenance modes. These set up features cover Ducted Evaporative Air Conditioning, Ducted Gas Central Heating and Dual Cycle Refrigerated Air Conditioning.

Important Note: Changes made to the set up modes outside the parameters set by your installer could have an adverse effect on the unit operation and life. Warranty could also be void.

The Setup modes include:

| | |
|--------------------|---|
| Coding | – All products |
| Diagnostics | – All products |
| Fan Speed Settings | – All products |
| Zoning Setup | – Heating / Dual Cycle Cooling |
| Zone Setup | – Multiple Evaporative Air Conditioners |
| Water Management | – Evaporative Air Conditioning |

PRODUCT IDENTIFICATION

The setup mode will cater for many options of heating / cooling unit configurations. As a result there are a number of potential product classes that the touch pad control system will control. The class is the first requirement for selection when coding or entering the setup mode.

| Class | Appliance Class | Code |
|-------|--|----------------|
| tP | Touch Pad Wall Control | tP:01 |
| H | Heater | H:01,02,03,04 |
| E | Evaporative A/C | E:01,02,03,04 |
| HC | Combined Heater – Dual Cycle Cooler | HC:01,02,03,04 |

For standard domestic applications with a single unit or heater cooler combinations the following default classes will be used:

| | |
|---|--------------|
| Ducted Gas Heating Only | HC 01 |
| Ducted Gas Heating c/w Dual Cycle Refrigerated Air Conditioning | HC 01 |
| Ducted Evaporative Air Conditioning | E 01 |
| Ducted Gas Heating and Evaporative Air Conditioning. | HC 01 & E 01 |



Controls – Installation / Setup / Commissioning

Coding

AUTO-CODING

The moment the power is applied to the control system the touch pad will scan for all the new equipment that has been installed and powered on. The powering up of a multiple configuration, a ducted central heater and a ducted evaporative air conditioner, must happen within 20 seconds of each other for the scan to find both units. If the scan misses one or the other units a forced scan can be done.

Important Note: Ensure all appliances are connected prior to powering up the system. Ensure also that the remote isolation switch, where fitted, is also turned on.

If you have a ducted central heater and you are adding an evaporative air conditioner to the touch pad or you are adding a ducted central heater to an evaporative air conditioner you can force the control to scan for the new equipment.

CODING DEFAULTS

- Ducted Gas Central Heating
 - ⇒ HC01 - Ducted Gas Heating and Dual Cycle Refrigerated Air Conditioning
 - ⇒ Thermostat Mode for Heating
 - ⇒ 4 Zones ON
 - ⇒ NO Common Zone – This can be set up subject to system design.
- Ducted Evaporative Air Conditioning
 - ⇒ E 01 – Evaporative Air Conditioning
 - ⇒ Thermostat Mode

FORCED SCAN AUTO-CODING:

To force a scan for new equipment:

1. Power up the new unit.
2. Within 3 minutes of the unit being powered up:
 - 2.1. Turn the touch pad ON
 - 2.2. Turn the touch pad OFF and keep holding the ON-OFF icon until the clock area shows - - - - .
Release the ON-OFF button and the touch pad will scan for the new unit and re-initialise.
3. When the time clock returns to normal, turn the touch pad on and check the unit has been coded successfully.
4. If the unit did not code restart the process by turning the power OFF then ON at the unit to reestablish the 3 minute coding window

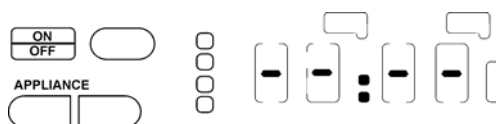

IMPORTANT NOTES

Things to note when connecting new products to a touch pad control

1. There is only a 3 minute coding window after the unit has been powered up to force a scan to find a new unit.
2. Central Heating will have a default configuration that includes Dual Cycle cooling and 4 available zones.
3. When a ducted evaporative air conditioner is added to a ducted central heater, the Dual Cycle cooling functions are no longer available for use.
4. The auto coding process can only discriminate between a single central heater and a single evaporative air conditioner



Controls – Installation / Setup / Commissioning

- Where there are multiple units of a single type (e.g. 2 up to 4 evaporative air conditioners) connecting to a single Touch Pad control call your Climate Technologies office for more information to setup and control multiple units.

Multiple Unit Setup – Heater / Cooler

Your Touch Pad control is capable of controlling more than one type of unit. For the Touch Pad control to communicate with each unit, the units must be coded to the Touch Pad. The following options may apply when adding a new unit:

- Installing Ducted heater and Evaporative Air Conditioning
- Adding a Ducted Heater to an Evaporative Air Conditioner
- Adding Dual Cycle Air Conditioning to a Ducted Central Heater
- Adding an Evaporative Air Conditioner to a Ducted Central Heater.

The following product codes will be available for coding the next new appliance to the Touch Pad control

| | |
|--------------------------------|-------|
| Heating | H 01 |
| Heating c/w Dual Cycle Cooling | HC 01 |
| Evaporative Air Conditioning | E 01 |

FORCE CODING A NEW / ADDITIONAL PRODUCT

When coding a new product there is a coding window of 3 minutes after the product has been powered on. Once the 3 minutes has finished the unit will not accept any coding information. If the 3 minutes has been exceeded before the coding process is completed, turn the power OFF then ON at the unit.

Coding a new / additional product.

- STEP 1** Ensure the control is in the OFF mode.
- STEP 2** A series of unseen icons must be pressed
- Press and hold the ZONE 4 (1) icon allowing for a triple BEEP followed by a single BEEP.
 - In quick succession press the unseen SETUP icons ENTER (2), REVIEW (3) & CLOCK (4).
 - If successfully executed the numeric area will display tP:01.
 - If unsuccessful repeat 1 and 2 of STEP 2.
- STEP 3** Press ENTER
- STEP 4** Using the arrows select 4 from the display. Press ENTER.
- COOL will flash in the APPLIANCE area and the TIME display will alternate between Co dE and E 01
- STEP 5** Using the arrows, select the new unit to be coded from the display e.g. E01, H01, and HC01. Press ENTER
- STEP 6** Press FINISH to exit.

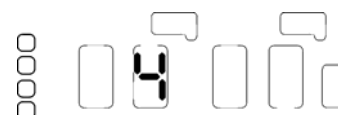
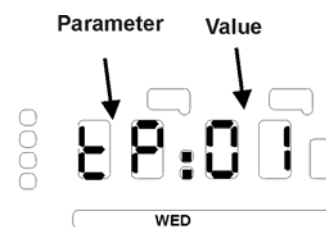
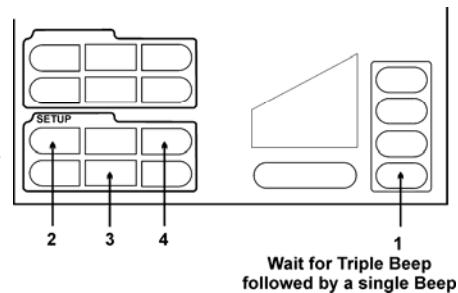



Controls – Installation / Setup / Commissioning

FAULT CODES ACCESS



The Touch Pad control can recover the last 5 faults that the unit diagnostics has stored. Fault code 1 is the current registered fault, while 2, 3, 4 & 5 is the fault code history.

1. At the time of the unit stopping and displaying the RESET icon. Press the RESET icon while the Touch Pad control is in the ON mode before resetting the unit.
2. Recovering the fault log after the unit has been reset. In the OFF mode press and hold the RESET icon outline till the numeric screen display changes.

VIEW THE FAULT CODE



There are a number of fault codes that can be registered subject to the failure or the product associated.

Step 1 Once the fault code log has been entered tP: 01 will be displayed.

Step 2 Using the   arrows select the unit that displays the APPLIANCE and reset icon (Reset Icon is not displayed after the unit has been reset). Press ENTER.



Step 3 The last fault code number will be displayed with number 0 and the fault code. Number 0 is always the most recent fault. See the fault code table next page.

Step 4 Using the   arrows, review fault codes for 0, 1, 2, 3 & 4. Number 0 will be the most recent.



Step 5 Press FINISH to exit.

Step 6 If the unit has not been reset, press and hold RESET icon until a BEEP is heard for the unit to recommence operation.



Controls – Installation / Setup / Commissioning

FAULT CODES FOR HIGH EFFICIENCY, MID EFFICIENCY HEATERS

| <i>Code No.</i> | <i>Fault Code</i> | <i>Diagnosis</i> |
|-----------------|--|---|
| 00 | No Activity | There has been no fault codes registered or the control has not been coded to the unit. |
| 01 | Block Flue | Check flue cowl installed correctly |
| 02 | Pressure Switch fused closed | Service Call |
| 03 | Combustion air pressure system failure | Check combustion fan OK. Service call. |
| 04 | Room air over temperature (auto reset) | Check Minimum Fan Speed, Duct design |
| 05 | Controller electronic malfunction | Reset, Service Call |
| 06 | Slow closing gas valve | Reset, Service Call |
| 07 | Ignition failure | Check: - igniter works, flame sensor, gas supply. For forced draft High Efficiency units also check blocked flue and blocked condensate drain. Service Call |
| 08 | Gas Interruption | Check gas supply, Flame Sensor, Service Call |
| 09 | EEPROM failure | Reset, Service Call |
| 11 | Missed Transmission | Check loom integrity and connections |
| 12 | No Communication (Touch Pad Only) | Touchpad cannot detect unit – check loom integrity and connections |
| 15 | No recorded fault codes | |



Controls – Installation / Setup / Commissioning

RESETTING THE TOUCH PAD CONTROL.

Resetting the Touch Pad Control will return the Touch Pad to its default settings for all configuration and program options.

This function does not reset the heater or cooler.

To reset the Touch Pad Control a number of unseen icons will need to be pressed.

- Step 1** Ensure the control is turned OFF.
- Step 2** Press the ZONE 4 (1) icon until a triple BEEP followed by single BEEP is heard.
- Step 3** In quick succession press COOL (2), CANCEL (3), FINISH (4) and THERM (5) icons.

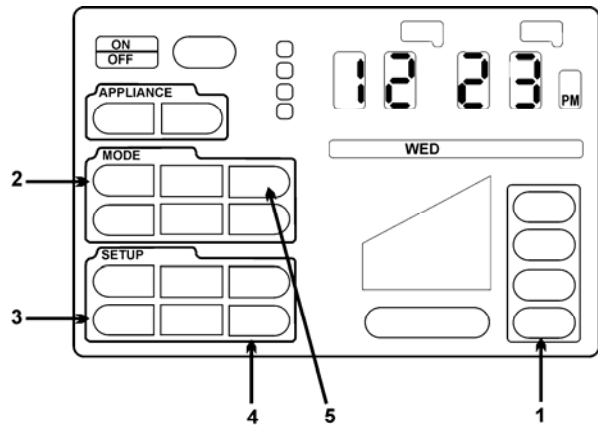

Wait for a Triple Beep followed by a single Beep

All the icons on the screen will now light up. They will slowly disappear one by one. Once all the icons have cleared it will take approximately 1 minute for the control to return to the OFF mode. The time will be displayed when the RESET is complete.

If unsuccessful restart from **STEP 1**.

CALIBRATING THE THERMOSTAT.

The thermostats come pre-calibrated from the manufacturer. However, should the thermostat require calibrating the following is the procedure. To enter into the installer maintenance to calibrate the thermostat:

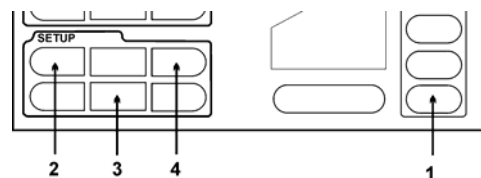

- Step 1** Ensure the control is in the OFF mode.
- Step 2** A series of unseen icons must be pressed
 - 1. Press and hold the ZONE 4 (1) icon allowing for a triple BEEP followed by a single BEEP.
 - 2. In quick succession press the unseen SETUP icons ENTER (2), REVIEW (2) & CLOCK (4).

If successfully executed the area will display tP:01.
- 3. If unsuccessful repeat 1 and 2 of STEP 2.

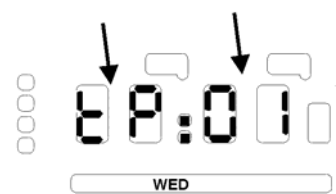

Wait for Triple Beep followed by a single Beep



- Step 3** Press ENTER. Parameter 1 is calibration mode and the value is the current temperature.
- Step 4** Press ENTER. The display will now change relative to the current temperature e.g. 23 °C.
- Step 5** Using the   to change the thermostat temperature value to the required settings. The value increments are 0.1°.
- Step 6** Press ENTER to save and finish.

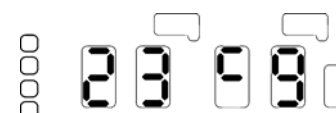
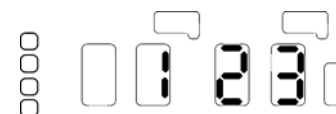

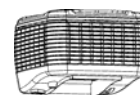

Controls – Installation / Setup / Commissioning

Evaporative Air Conditioning Setup

SETTING THE WATER MANAGEMENT SYSTEMS PARAMETERS AND VALUES

There are 4 setup modes available in the water management as set out in the table below. The use of these modes is based on 2 selection criteria:

- Parameter 1 – DUMP VALVE DELAY This provides the option for a 1 hour delay before dumping the water from the tank. This function is particularly useful when the unit is being used in THERM mode as it will stop premature dumping of the water.
- Parameter 2 – PRECOOL: The option to have the pump run for 2 minutes before the fan starts. The benefit is that when the fan starts cool air will be delivered immediately.
- Parameter 3 – DUMP INTERVALS: This option provides the available hourly dump cycle times available. These should be set according to water hardness in the supply.
- Parameter 4– PREFILL: The option provides the availability to have the valve prefill the tank for 2 minutes before starting the pump operation.

Water Management Table – Evaporative Air Conditioning.

| Installer Maintenance | Parameter | Default | OFF Value | <i>ON Value</i> |
|---------------------------|-----------|---------|-----------|----------------------------|
| Dump Delay after shutdown | 1 | 01 | 00 = OFF | 01= 1 hr |
| Pre-Cool | 2 | 00 | 00 = OFF | 01 = 3.0 min |
| Dump Interval | 3 | 12 | 00 = OFF | 01, 02, 04, 08, 12, 24 hrs |
| Pre-Fill | 4 | 00 | 00= OFF | 01 |

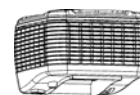

Controls – Installation / Setup / Commissioning

Setting the Water Management Systems Parameter Table.

To enter into the installer setup mode for the water management options use the following steps.

Step 1 Ensure the control is in the OFF mode.

Step 2 A series of unseen icons must be pressed

1. Press and hold the ZONE 4 (1) icon allowing for a Triple BEEP followed by a Single BEEP.
2. In quick succession press the unseen APPLIANCE COOL (2) icon followed by the HEAT (3) icon.
3. If successfully executed the area will display tP:01.
4. If unsuccessful repeat 1 and 2 of STEP 2.

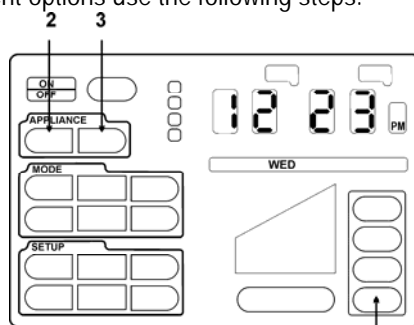

1
Wait for Triple Beep followed by a single Beep

Step 3 Using the to select E:01 from the display area.



Step 4 Press ENTER. The display will now change to 1:01.

Step 5 Using the arrows, select the parameter to be changed as per the Water Management Table. Press ENTER.

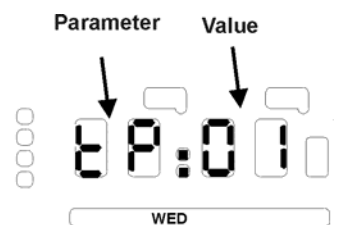

Step 6 Using the to change the value as per the 'Water Management Table'. Press ENTER.



Step 7 To change more water management parameters repeat Step 4 – 7.

Step 8 Press FINISH to exit.

Where multiple units have been connected to a single touchpad, this procedure will have to be repeated for each of the units connected – E01, E02 etc.

SETTING THE WATER LEVEL & BLEED RATE

There are 3 diagnostic modes available for use of which Parameter 2 and 3 can be used to assist the setting of water levels in the unit. See the table below.

Diagnostic Table

| Installer Maintenance | Parameter | Value | Duration |
|-----------------------|-----------|-------|------------|
| Unit Run Time | 1 | Rt | ---- x 100 |
| Fill Valve | 2 | 00 | 10 Minutes |
| Fill Valve & Pump | 3 | 00 | 20 Minutes |

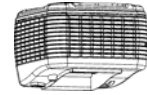

Controls – Installation / Setup / Commissioning

To enter into the installer maintenance / diagnostic mode to check water level and pump function, use the following steps:-

- Step 1** Ensure the control is in the OFF mode.
- Step 2** A series of unseen icons must be pressed
1. Press and hold the ZONE 4 (1) icon allowing for a triple BEEP followed by a BEEP.
 2. In quick succession press the unseen APPLIANCE COOL (2) icon 2 times.
- If successfully executed the numeric area will display **tP 01**.
3. If unsuccessful repeat 1 and 2 of STEP 2.

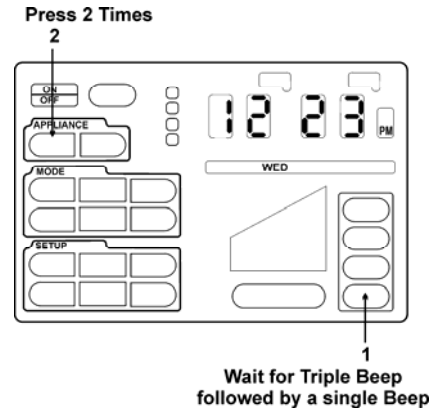

- Step 3** Using the to select **E:01** from the numeric display area.
- Step 4** Press ENTER. The display will now change to **1 rt**.
- Step 5** Using the arrows, select the diagnostic 2 or 3 as per the Diagnostic Table on this page. Press ENTER. **00** will flash for the duration period.
- Step 6** To exit the diagnostic, press ENTER.
- Step 7** To select the other diagnostic parameter repeat Step 5 & 6.
- Step 8** Press FINISH to exit.

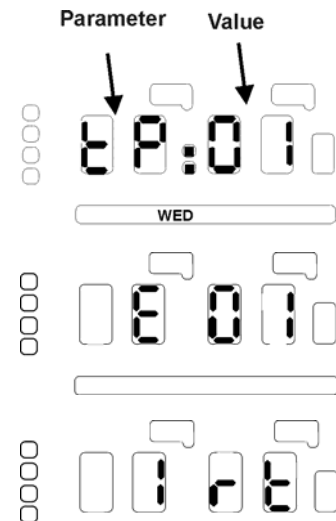

FAN SPEED SETTINGS

There are 2 available fan speed setting options for evaporative air conditioning as set out on the Fan Speed Chart. Minimum fan speed should not go below 500 RPM else the fan motor will stop and start because of over temping.

NOTE: fan speed settings should **ONLY** be set by a qualified installer or service technician

Fan Speed Chart

| Installer Maintenance | Parameter | Default | Value Range |
|-----------------------|-----------|---------|-------------|
| Low Fan Speed | 1 | 13 | 0 – 35 |
| High Fan Speed | 2 | 35 | 0 - 35 |

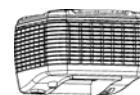

Controls – Installation / Setup / Commissioning

To enter into the installer maintenance to adjust minimum and maximum fans speeds, the following steps must be followed.

Step 1 Ensure the control is in the OFF mode.

Step 2 A series of unseen icons must be pressed

1. Press and hold the ZONE 4 icon allowing for a triple BEEP followed by a single BEEP.

2. In quick succession press the unseen SETUP icons ENTER, REVIEW & CLOCK.

If successfully executed the numeric area will display tP:01.

3. If unsuccessful repeat 1 and 2 of STEP 2.

Step 3 Using the select E:01 from the numeric area display.

Step 4 Press ENTER. The display will now change to 1 13 or what ever the last setting was made to.

Step 5 Using the select the low or high speed parameter for change. Press ENTER. The fan will begin operation.

Step 6 Using the change the value / fan speed setting. Press ENTER to save the revised setting.

Step 7 To change the other fan speed parameter repeat Step 5 – 6.

Step 8 Press FINISH to exit.

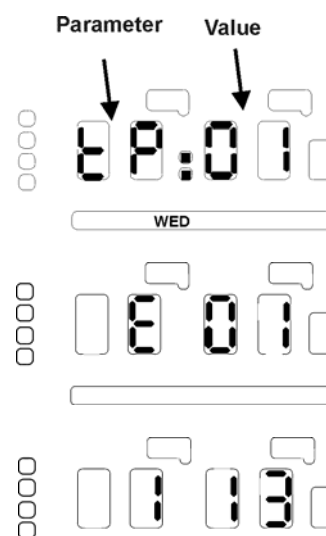
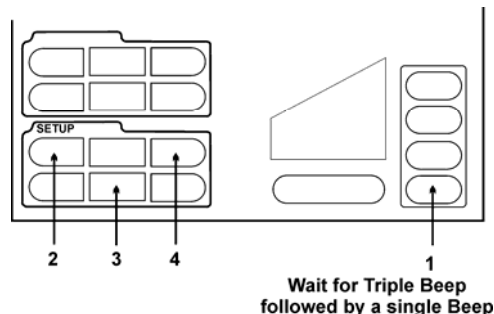

Multiple Unit Setup – Evaporative Coolers

When multiple EAC units are used on a single touchpad, they have to be allocated to a zone to ensure their function. There can only be one unit per zone which means a total of 4 EAC units per touchpad. There are 4 steps to complete a successful installation:

1. Connect the low voltage cables between the units and power up.
2. Code the unit
3. Rescan
4. Turn off the common zone.

Coding the units

Step 1 Turn the power on to the appliances being coded at the control box. Check the green LED is visible.

Step 2 Press and hold down the RESET button in the unit control box for 25 seconds.

At the 25 second mark, the green LED will start to flicker. Do not release the button at this point.

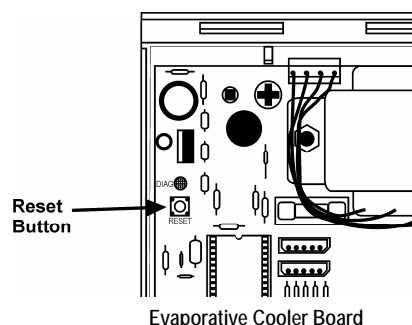

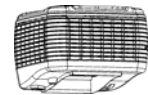

Controls – Installation / Setup / Commissioning

Step 3 The LED will now flicker a sequence of 1 through to 4 flickers with a pause in between each set of flickers. To allocate the unit to the correct zone, release the reset button immediately after the required number of flickers has been completed. See Table.

Evaporative Air Conditioners

| LED Flickers | Zone Allocation | Unit Identification Code |
|--------------|-----------------|--------------------------|
| 1 | ZONE 1 | E01 |
| 2 | ZONE 2 | E02 |
| 3 | ZONE 3 | E03 |
| 4 | ZONE 4 | E04 |

Step 4 Move to the next unit and perform the same procedure as in Step 2 and Step 3, to allocate a code number to each unit.

NOTE:- Each unit must be on a separate zone. More than one unit on a zone will result in a communication conflict causing inconsistent operation of the units.

SETTING THE COMMON ZONE FOR MULTIPLE UNITS

To ensure ZONE 1 is available for use on the touchpad, the common zone must be turned off. To do this you must enter the zone availability parameters and turn off the common zone default setting.

STEP 1 Ensure the control is in the OFF mode.

STEP 2 A series of unseen icons must be pressed

1. Press and hold the ZONE 4 (1) icon allowing for a Triple BEEP followed by a Single BEEP.
2. In quick succession press the unseen APPLIANCE COOL (2) icon followed by the HEAT (3) icon.
3. If successfully executed the numeric area will display tP:01.
4. If unsuccessful repeat 1 and 2 of STEP 2.

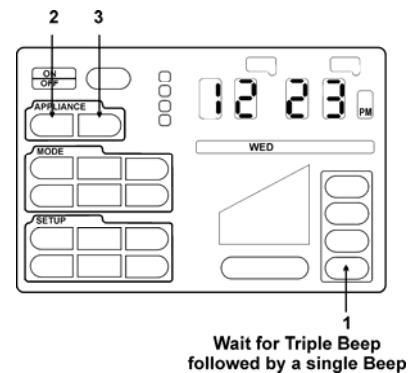

STEP 3 Press ENTER.

STEP 4 Using the arrows, for an evaporative air conditioner and select E01. Press ENTER.

STEP 5 Press the ON/OFF button so it is no longer solid.

STEP 6 Press FINISH

SCAN FOR PRODUCTS:

To access the units allocated to the zones, a forced scan must be complete with the touchpad.

STEP 1 Turn the touch pad ON

STEP 2 Turn the touch pad OFF and keep holding the ON-OFF icon until the numeric area shows ----.

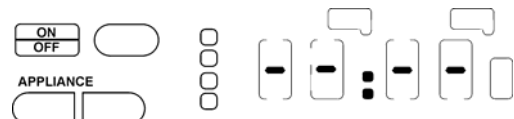

STEP 3 Release the ON-OFF button and the touch pad will scan for the new unit and re-initialise.

STEP 4 When the time clock returns to normal, turn the touch pad on and check the units have been successfully located to their zone.

STEP 5 Turn the zones on and check the units function.

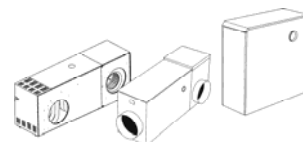

Controls – Installation / Setup / Commissioning

Ducted Gas Central Heating

SETTING FAN SPEEDS – HIGH / LOW

There are 2 available fan speed setting options for ducted gas central heating as set out on the Fan Speed Options Chart. Minimum fan speed should be set so that the heater does not go out on over temperature.

NOTE: fan speed settings should **ONLY** be set by a qualified installer or service technician

Fan Speed Options

| Installer Maintenance | Parameter | Default | Value Range |
|--------------------------------|-----------|---------|-------------|
| Low Fan Speed | 1 | 27 | 0 – 35 |
| High Fan Speed | 2 | 35 | 0 – 35 |
| High Fan Speed – Dual Cycle AC | 3 | 35 | 0 – 35 |

To enter into the installer maintenance to adjust minimum and maximum fans speeds, the following steps must be followed.

Step 1 Ensure the control is in the OFF mode.

Step 2 A series of unseen icons must be pressed

1. Press and hold the ZONE 4 (1) icon allowing for a triple BEEP followed by a single BEEP.
2. In quick succession press the unseen SETUP icons ENTER (2), REVIEW (3) & CLOCK (4).

If successfully executed the clock area will display tP:01.

3. If unsuccessful repeat 1 and 2 of STEP 2.

Step 3 Using the to select H 01 or if Dual Cycle cooling is fitted HC 01 from the clock display area.

Step 4 Press ENTER. The display will now change to 1 27 or any other previous setting.

Step 5 Using the to select the parameter to be changed. Press ENTER. The heater will begin operation.

NOTE:- Wait for the heater to be fully functional before adjusting the fan speeds.

Step 6 Using the to change the value / fan speed setting. Press ENTER to save the revised setting.

Step 7 To change the other fan speed parameter repeat Step 5 – 6.

Step 8 Press FINISH to exit.

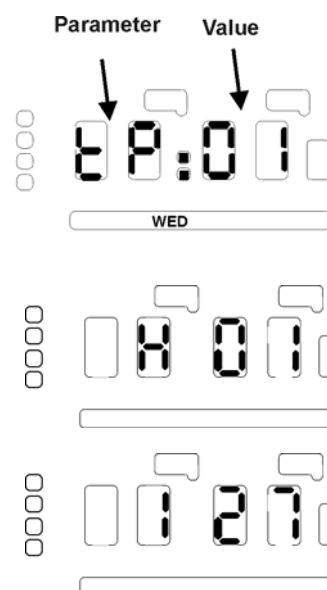
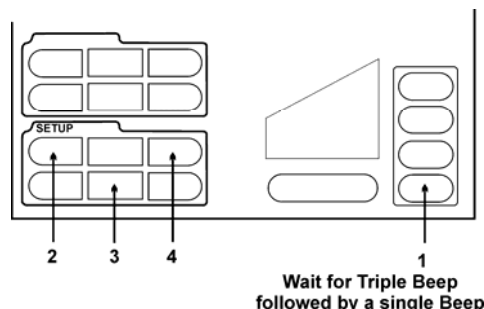

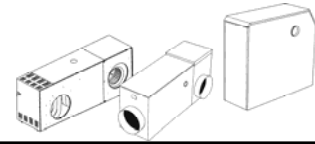

Controls – Installation / Setup / Commissioning

SETTING FAN SPEEDS - ZONING

As the central heater fan will attempt to run at maximum when the temperature is more than 2° under the SET temperature, certain zone configurations may have unacceptable air noise. With the Touch Pad control you can set the maximum fan speed for particular zone combinations.

To set the maximum fan speed with a particular zone configuration:

Step 1 Turn the heater ON. Set the temperature so the heater will run.

Step 2 Set the MODE of the Heater to **BOOST**.

Step 3 Select the Zone combination required to set the maximum speed. A total of 16 different combinations can be created. Wait 30 seconds for the zone motors to open or close.

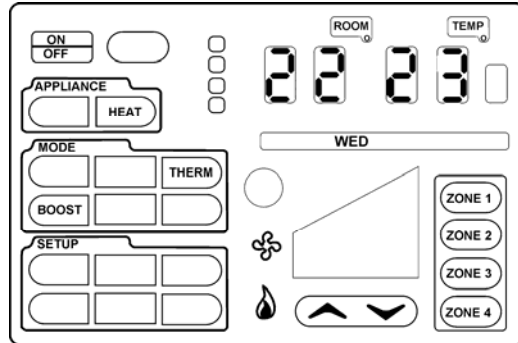

Step 4 Press and Hold the **BOOST** button until the screen changes in the numeric display to **SP 35** or any other revised setting. (35 is the default high speed setting.)

Step 5 Adjust the fan speed to suit the maximum air required. After 10 Seconds of no activity the setting will be saved. If further adjustment is required, repeat STEP 4.

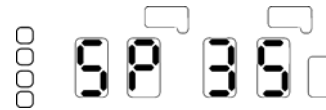

Step 6 When that combination is complete wait for the setting to automatically save or press ENTER.

Step 7 For further combination settings, repeat steps 4 – 6.

Step 8 When all the combinations required have been completed press FINISH.

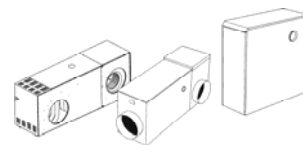

Controls – Installation / Setup / Commissioning

SETTING THE ZONE AVAILABILITY - HEATING

If during the coding process the zones available did not configure correctly or zones have been removed or added, the Touch Pad can be configured to suit the changes.

To enter into the installer maintenance to set the zone availability, the following steps must be followed.



Step 1 Ensure the control is in the OFF mode.

Step 2 A series of unseen icons must be pressed

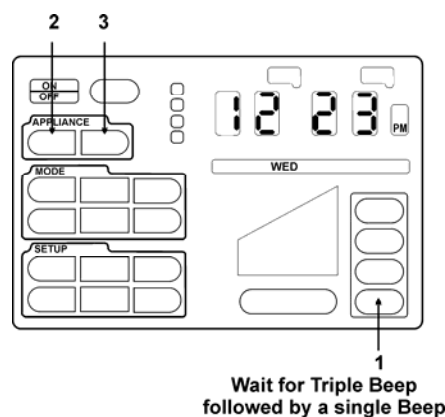
1. Press and hold the ZONE 4 (1) icon allowing for a Triple BEEP followed by a Single BEEP.
2. In quick succession press the unseen APPLIANCE COOL (2) icon followed by the HEAT (3) icon.
3. If successfully executed the clock area will display tP:01.
4. If unsuccessful repeat 1 and 2 of STEP 2.



Step 3 Press ENTER.

Step 4 Using the   arrows, for a single ducted gas central heater, select HC:01.

HC:01 is the default code setting. If the unit has been forced coded with another unit option eg H 01, new unit option will have to be selected to recognise the common zone.

Press ENTER.

Step 5 The ON/OFF icon and the 4 zone icons will flash.

To see the current zone selection press anywhere in the zone outline. All icons that are solid will be the current selection. To change the zone selection requirement there are 3 options:

- **No Zone Motors Installed.** Press the ON / OFF icon to make it solid. This turns on the common zone feature. Press any zone icons that are solid to make them all flash and turn off their availability.
- **Zone Motors Only.** Make 2, 3 or 4 zones available. Press the zones not required by making them flash to turn off their availability.
- **Common Zone plus Zone Motors:** This option can only be used if there is adequate duct work to handle the air that is not controlled by a zone motor.

Press the ON/OFF button to making the icon Solid. This turns ON the common zone feature.

Press the zone icons not required by making them flash and turn off their availability.

Step 6 Press ENTER. The zones have now been reconfigured. See options next page.

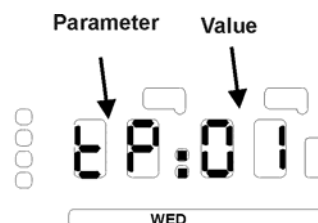

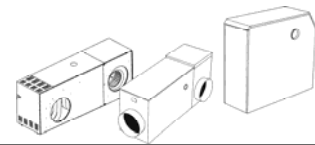

Controls – Installation / Setup / Commissioning

Option 1:- H 01 / HC01 Ducted Gas Central Heating

The ON/OFF icon and the 4 zone icons will flash.

The default setting for zoning is 4 zones on with no common zone. Press ENTER at this point if no change is required.

If changes are required, the zone availability can be set using the following options:

- **No Zone Motors Installed.** Press the ON / OFF icon to make it solid. This turns on the common zone feature. The zone icons are all solid. Press each zone icon to make them all flash to turn off their availability.
- **Zone Motors Only.** Make 2, 3 or 4 zones available. Press anywhere in the zone area and the 4 zones will become solid. Press the zones not required by making them flash to turn off their availability.
- **Common Zone plus Zone Motors:** This option can only be used if there is adequate ductwork to handle the air that is not controlled by a zone motor.

Press the ON/OFF button to making the icon Solid. This turns on the common zone feature.

The zone icons are all solid. Press the zone icons not required by making them flash to turn off their availability.

If you make a mistake with zoning this can be corrected in *SETTING THE ZONE AVAILABILITY*.

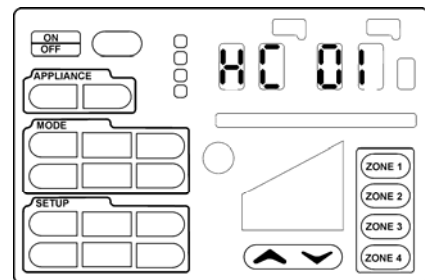
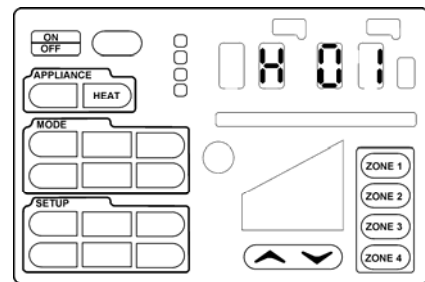

Option 2:- HC 01 Ducted Gas Central Heating / DUAL CYCLE Refrigerated Air Conditioning

For Dual Cycle Cooler refrigerated air conditioning HC 01, use the Option 1:- H:01 Ducted Gas Heating on this page for zone setup.

- Step 7** Press ENTER. The unit is now coded. After 30 seconds of initialization the control will be ready for operation

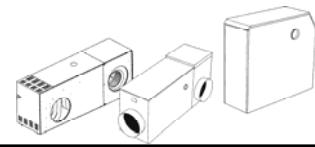

Controls – Installation / Setup / Commissioning

COMMISSIONING CHECK LIST

GENERAL

- All equipment ordered by the customer is installed.
- The unit is level and secure.
- The mains and control wiring are complete and the circuit breaker and GPO are turned ON.
- All Controller functions for the appliance operate.
- All electrical or gas connections are to manufacturers specifications and the relevant electrical or gas standards and codes.

UNIT – DUCTED HEATING

- Electrical polarity of the power outlet is correct.
- Heater is installed away from sources of dust and fumes (i.e. pool chlorine/petrol etc).
- Gas leaks checked for, none present.
- Flue outlet pipe complies with limits given / code and is sealed waterproof.
- Combustion air meets requirements (internal, under floor).
- Fan speed set is correct.
- Burner pressure is correct.
- Mounting pad/platform complies with requirements / codes.

UNIT – DUAL CYCLE REFRIGERATED AIR CONDITIONING

- Unit Foundation correct
 - All pipe work is welded and vacuumed down.
 - Condenser Coil is purged before charging.
 - System is charged, all joints checked and pressures set correctly
 - Condenser unit is level
 - All clearances around the condenser set to manufacturers specifications.
-

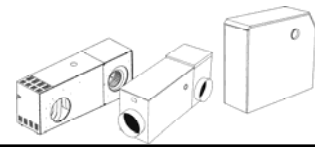

Controls – Installation / Setup / Commissioning

UNIT - DUCTED EVAPORATIVE AIR CONDITIONER

- The water supply line has been flushed to clear swarf and debris and is free of leaks.
- The tank is free of foreign matter and debris and the water isolating tap is turned ON.
- Water drainpipe work is completed and sealed.
- The water basin fills with water and the float valve closes correctly when the water level is 65-70mm below the overflow level.
- The water pump operates correctly when turned ON at the controller.
- The Dialflo water bleed rate is adjusted to suit local water conditions.
- The Dump Valve. The tank drains correctly when unit turns off.
- The fan deck is correctly located and the fan blade spins freely.
- The fan operates through the entire speed range.
- The minimum fan speed is correctly set.
- Water distribution is even with the filter pads fitted and the air conditioner operating pump and fan.

DUCTWORK

- All ductwork is completed to plan, correctly supported and airtight, with no bend less than 1.5 x the ductwork diameter.
- Air distribution checked, dampers are adjusted and all outlets correctly adjusted and wiped clean.
- All roof penetrations are fully sealed and watertight.
- Manhole cover replaced.

SITE

- All rubbish has been removed from inside and on the roof.

CUSTOMER HAND OVER

- The operation of the Controller.
 - The need to open windows and doors for the correct operation of Fresh Air Conditioning
 - The operation of the bleed or dumping system and it's importance to operate all the time in ducted evaporative air conditioning
 - Maintenance requirements
-

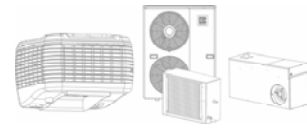

Warranty – Australia ONLY

IMPORTANT:

Please read this warranty information and complete the Dealer/Product information on the following page. KEEP this with your original purchase documents for any claim under warranty.

Firstly refer to your owners manual to ensure you have followed the correct operating procedures of your product, and refer to the trouble shooting guide to assist solving any problems you may have.

1. Read this warranty statement carefully before you request warranty service as items relation to installation are not covered by this appliance warranty.
2. A proof of product purchase must be provided for warranty service, to validate the appliance is within the manufacturer's warranty periods.
3. This warranty is only for products and associated original controls for Climate Technologies manufactured product.
4. Only an authorised Climate Technologies service provider must carry out warranty service.

Climate Technologies provides the following Manufacturers warranty additional to all implied warranties and other statutory rights which you may have under the Trade Practices Act and similar State & Territory Laws, subject to the following terms and conditions.

Conditions to warranty

- Subject to the exclusions noted, Climate Technologies warrant the product for the period as prescribed in the table following this statement to be free from Inherent defects in materials and workmanship for functional and structural components.
- This product is only valid if the product is operated in accordance with the manufacturers instructions
- The appliance must not be modified or changed in any way.
- Your proof of purchase MUST be produced before free service will be provided.
- Traveling time and mileage are included within 30km of either your authorised Climate Technologies dealer or service provider's premises. Customers in areas other than the above are responsible for any traveling time and mileage required to carry out warranty repairs.
- The product must be installed by a qualified person in the manner prescribed by local & statutory regulations and to the manufacturer's specifications.
- Service within the terms of this warranty will be recognised where we are satisfied that the appliance or part was supplied within the relevant time limits. Documents of purchase and Dealer/Installer information will assist in this process.
- Product fitness for purpose and overall system design / sizing is solely the responsibility of the dealer / installer. This includes but is not limited to heat load calculations, air flow, system balancing, humidity, water quality etc.
- The product must be installed in an easily and safe accessible area for service, appliances installed in areas not easily and safely assessable, costs will be borne by the owner for access equipment should maintenance be required.

DIY installation Warranty

- If the product has been installed as a DIY, a supply part only warranty will apply. Parts only will be supplied free of charge on the return of the faulty part and the owner will be responsible for all labour charges incurred for the part to be fitted by a qualified person. Labour warranty as prescribed in the following table is void in this situation.

Remote Location Warranty

- If the product has been installed outside the Climate Technologies service network, a supply part only warranty will apply. Parts only will be supplied free of charge on the return of the faulty part and the owner will be responsible for all labour charges incurred for the part to be fitted by a qualified person. Labour warranty as prescribed in the following table is void in this situation.
-

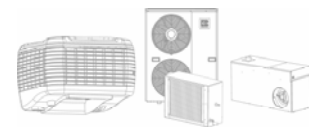

Warranty – Australia ONLY

Exclusions to warranty

- Consumable items subject to wear and tear such as filter pads, drive belts and bearings are not covered by this warranty.
- Components used as part of the installation such as grilles filters, ducting, fittings, zone motors and consumer services pipe work are warranted from your place of purchase and not covered by this warranty.
- Damage caused by elements such as wind, rain, lightning, floods etc along with power spiking and brownouts are not considered defective material or workmanship and as such are not considered warranty.
- No responsibility will be accepted for outside elements such as pests, animals, pets and vermin that may cause damage to the unit.
- Harsh environmental situations such as salt air that may cause cabinet damage / rusting can not be considered warranty.
- The manufacturer does not accept liability or any claims for damage to building contents, carpet, walls, ceilings, foundations or any other consequential loss either direct or indirect. Damage resulting from, power spikes, incorrect operation, incorrect installation, and incorrect maintenance is also not covered.
- All warranties are NOT transferable.

Conditions where warranty may be void

- If there is no certificate of compliance for plumbing, electrical or refrigeration as required by State & Territory Laws. Climate Technologies reserves the right to refuse service on non-compliant installations.
 - The defective operation of the appliance that is due to failure of electricity, gas, water or refrigerant gas supplied.
 - Defects are caused by neglect, incorrect application, abuse or by accidental damage of the appliance.
 - An unauthorised person has attempting to repair the appliance.
 - A situation arises referenced in the trouble-shooting guide.
 - A charge will be made for work done or for a service call where there is nothing wrong with the appliance.
-

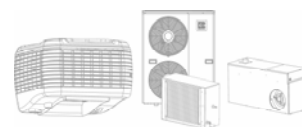

Warranty – Australia ONLY

PERIODS OF WARRANTY – YEARS BY PRODUCT AND APPLICATION:

Ducted Gas Heating

| Unit Components | RESIDENTIAL | | COMMERCIAL | |
|------------------------|-------------|--------|------------|--------|
| | Parts | Labour | Parts | Labour |
| Heat Exchanger | 10 | 3 | 2 | 2 |
| Burner | 10 | 3 | 2 | 2 |
| **All other components | 3 | 3 | 1 | 1 |

** Return air filter/s and zone motors are field supplied and therefore are not covered by the above warranty periods.

Dual Cycle Refrigerated Air Conditioning

| Unit Components | RESIDENTIAL | | COMMERCIAL | |
|------------------------|-------------|--------|------------|--------|
| | Parts | Labour | Parts | Labour |
| Compressor | 5 | 5 | 2 | 2 |
| **All other components | 5 | 5 | 2 | 2 |

** Return air filter/s and zone motors are field supplied and therefore are not covered by the above warranty periods.

Ducted Evaporative Air Conditioning - Domestic

| Unit Components | RESIDENTIAL | | COMMERCIAL | |
|-------------------------|-------------|--------|------------|--------|
| | Parts | Labour | Parts | Labour |
| Corrosion on Cabinet | 25 | 3 | 2 | 2 |
| Structural Guarantee | 10 | 3 | 2 | 2 |
| ** All other components | 3 | 3 | 1 | 1 |

** Filter pads are a consumable and are therefore not covered by this warranty

Aged New Product Warranties

For a New Product warranty to apply, a product needs to be sold and installed within 3 years of the manufacturing date.

Product that is aged as the result of extended storage or being used for demonstration purposes, the following warranty will apply.

- For a product that is greater than 3 years and less than 5 years old from date of manufacture the statutory warranty will apply and any voluntary warranty originally supplied will be reduced by 1 year
- For a product that is greater than 5 years of age from date of manufacture, the statutory warranty will apply to electrically functioning components only. All other components being cabinets, louvres, filters etc. will not be covered by warranty.

WARRANTY ON REPLACEMENT PARTS:

Parts replaced under warranty are warranted for the balance of the original warranty period.

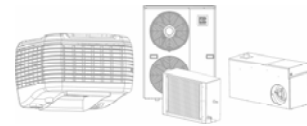

Warranty – Australia ONLY

PROOF OF PURCHASE:

It is important that the name of the Dealer or Retailer from whom you purchased your product and the name of the installer are recorded on this page. The installer is responsible for the correct installation, start up and demonstrating the operation of this product. The Dealer or retailer is also responsible for issuing the relevant certificates of compliance for the electrical connections. (These may differ from state to state)

Please attach your proof of purchase here. Your receipt is your warranty and will be required to validate any warranty.

DEALER PRODUCT INFORMATION:

| | |
|----------------------|------------|
| Dealer/Retailer: | |
| Dealer Address: | |
| Dealer Phone Number: | |
| Unit Model Number: | |
| Serial No: | |
| Date Installed: | |
| Serial No: | |
| Date Installed: | |
| Serial No: | |
| Date Installed: | |
| Installed by: | |
| Date Commissioned: | |
| Commissioned by: | Signature: |

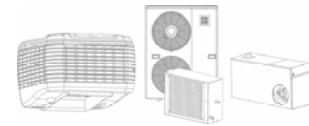

Service

SERVICE CENTRES:

Only qualified service personnel should conduct any service work carried out on your heating / cooling ducted system. It is important that periodical service is carried out on your product to ensure you will receive the efficiency benefits the product provides.

For Metro Service only ring the numbers below.

South Australia/ (08) 8307 5230

Northern Territory

New South Wales / (03) 8795 2457

Australian Capital Territory

Western Australia (08) 9454 1000

Victoria/Tasmania (03) 8795 2456

Queensland (03) 8795 2457

Outside Metro areas please contact your nearest Climate Technologies Service Provider.

New Zealand (ABERGAS LTD) 0800 161 161



“Excelling today for a better tomorrow”

Manufactured by
Climate Technologies
ABN 13 001 418 042

26 Nylex Avenue
Salisbury, SA 5108
Australia

www.climatetechnologies.com.au